

BLU-JET NH3 Applicator
by Unverferth

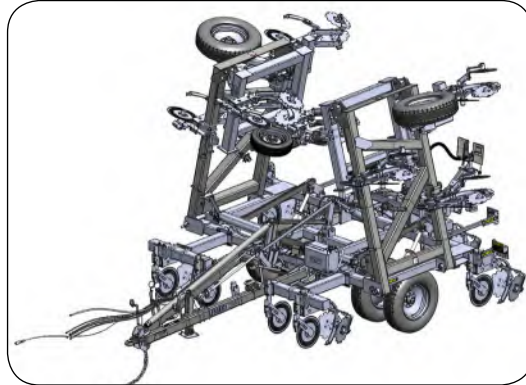

Legacy

Beginning with Serial Number A66360100

Part No. J0605010

Foreword



This symbol identifies important safety messages. When you see it, read the message that follows and be alert to the possibility of personal injury.

Remember, safety instructions stated in this manual are for your protection. Read them carefully and follow them closely when working around or using this machine.

Read and study this manual completely before attempting to operate this implement. Take this manual to the field for handy reference when operating, adjusting, or servicing your machine.

When referenced, “Right-Hand” (RH) and “Left-Hand” (LH) side of the machine are determined by standing behind the machine and facing in the direction of travel.

Pre-Delivery Checklist

- Hardware tightened
- Machine lubricated
- Safety and operating procedures reviewed
- Field adjustment information reviewed
- Warranty information reviewed

IMPORTANT

The information, specifications, and illustrations in the manual are based on the information available at the time it was written. Due to continuing improvements in the design and manufacture of Unverferth products, all specifications and information contained herein are subject to change without notice.

Product Information

When ordering parts or when requesting further information or assistance, always give the following information:

- Machine name
- Model
- Serial number

All products manufactured by Blu-Jet are warranted to be free from material and workmanship defects for one full year from time of consumer delivery. Your local dealer will gladly assist you with any warranty questions.

Please fill out and retain this portion for your records.

Purchase Date _____ Model _____ Serial Number _____

Dealer _____ City _____

Dealer Contact _____ Phone _____

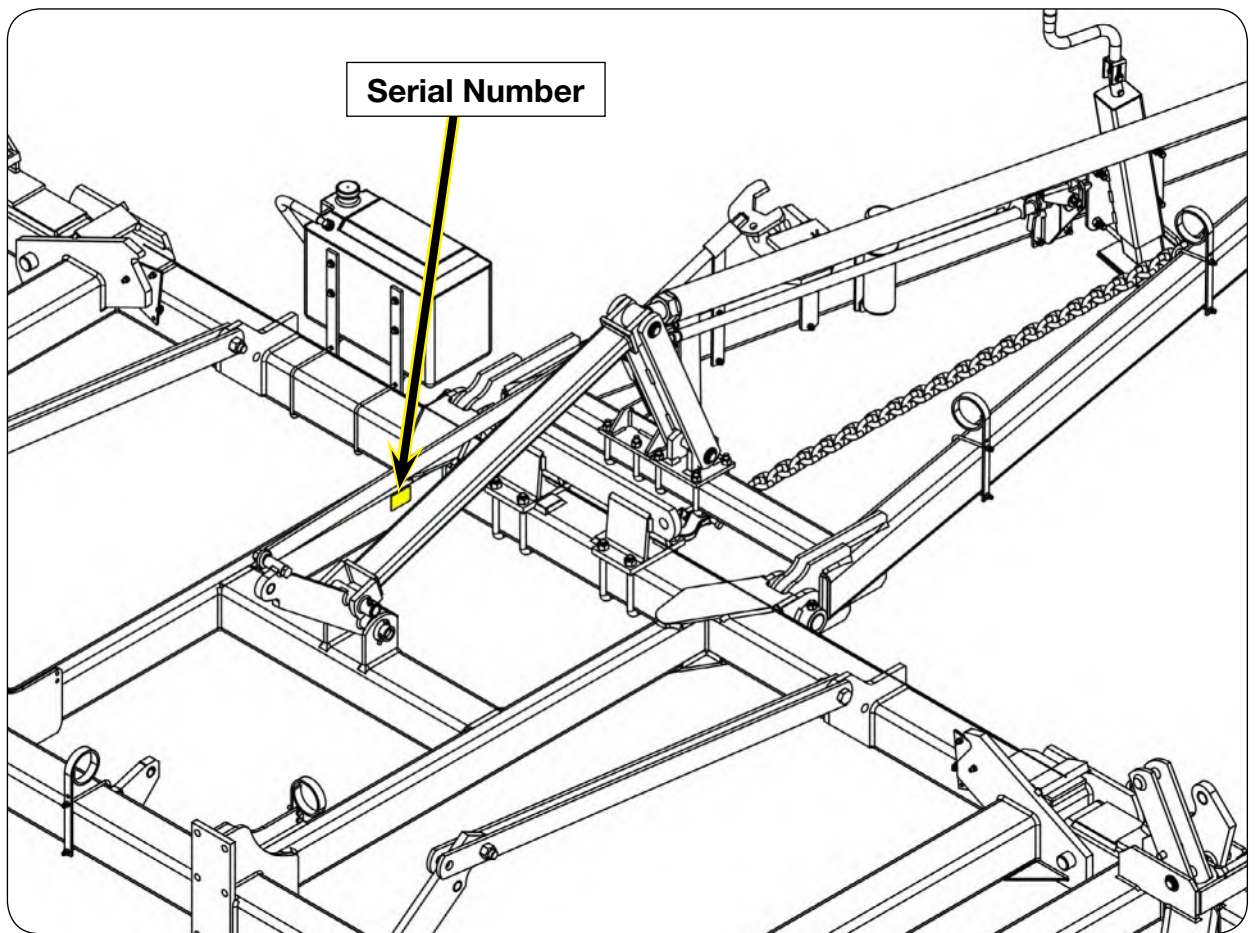

TABLE OF CONTENTS

Foreword 2
Pre-Operation Checklist 2

SECTION I
Safety

General Hazard Information 1-2
Safety Decals 1-3
Following Safety Instructions 1-6
Before Servicing 1-6
Before Operating 1-7
During Operation 1-7
Before Transporting 1-8
During Transport 1-8
Pressurized Oil 1-9
Chemical Hazards 1-10
Preparing for Emergencies 1-10
Wearing Protective Equipment 1-11

SECTION II
Set Up

Set Up 2-2
Tongue Assembly to Main Frame Assembly 2-3
Attaching Depth Stop and Routing Hoses 2-5
Nurse Tank Hitch Assembly 2-6
Transport Lighting Assembly 2-7
SMV Assembly 2-9
Mounting Offset Stagger & Double Extension Brackets 2-10
Sealer II Assembly (JAAM2857) - Optional Sealer II Spring Add-On Kit 2-11
Torsion Arm Assembly 2-12
 Attaching Bearings and Basket to Mounting Arms 2-12
 Position Basket on Torsion Spring Assembly 2-12
 Center Basket 2-13
 Attaching Torsion Arm Assembly to MaxPac Basket Mount Arm 2-13
 Attaching Torsion Arm Assembly to 6"x6" Tube (JAAM2630) 2-14
MaxPac AR700 Assembly 2-15
Residue Manager Assembly 2-16
Legacy 38' and 42' Toolbars 2-17
Legacy 47' and 52' Toolbars 2-18
Overhead Layouts - Legacy 2-19
Overhead Layouts - Legacy SD 2-33
Raven RCM Guide 2-39

TABLE OF CONTENTS

SECTION III
Operation

Preparing Tractor3-2

Preparing Applicator.....3-2

 Hardware.....3-2

 Pivot Pins3-2

 Hitch3-2

 Hydraulic System.....3-2

 Tires/Wheels.....3-3

 Lubrication3-3

Hitching to the Tractor.....3-4

 Drawbar Hitching.....3-4

 Transport Chain3-5

 Hydraulic Connections.....3-6

 Electrical Connection3-6

Jack Usage.....3-7

 Parked Position.....3-7

 Transport Position.....3-7

Transporting3-8

 Drawbar Connection3-8

Toolbar Operation.....3-9

 Leveling Machine.....3-9

 Leveling Adjustable Gauge Wheels.....3-10

 Pin Adjust Gauge Wheels.....3-11

 Depth Adjustment3-12

 Locking Depth Adjustment Linkage.....3-12

Hydraulic System Charging.....3-13

Folding Toolbar.....3-14

Nurse Tank Hitch.....3-15

Anhydrous Ammonia Operating Instructions3-16

 Checking System.....3-16

 Connecting Nurse Tank3-16

 Disconnecting Nurse Tank.....3-17

Coupler Operations3-18

Orifice Block Setting.....3-20

Clean Water Tank3-21

Torsion Arm Basket (Options).....3-21

SuperShooter (Options)3-22

MaxPac AR700 (Options)3-22

Residue Manager (Options).....3-22

TABLE OF CONTENTS

SECTION IV
Maintenance

Lubrication	4-2
Legacy Maintenance	4-4
Seasonal Storage.....	4-4
Purging A Hydraulic System.....	4-5
Schematics.....	4-6
Wheel, Hub and Spindle Disassembly and Assembly.....	4-8
Wheels and Tires.....	4-10
Wheel Nut Torque Requirements.....	4-10
Tire Pressure	4-11
Tire Warranty.....	4-11
Complete Torque Chart.....	4-12
Hydraulic Fittings - Torque and Installation.....	4-14
NH3 Fittings - Torque and Installation.....	4-15

TABLE OF CONTENTS

SECTION V

Parts

Clean Water Tank Components	5-2
Hitch, Transport Chain, Manual Holder and Jack.....	5-4
Depth Control Components.....	5-6
Main Frame Components.....	5-8
Primary Wing Components	5-10
Secondary 5’8” Wing Components.....	5-12
Secondary 3’2” Wing Components.....	5-14
Secondary Wing Extension to 50 Ft.....	5-16
Straight Extension Kit.....	5-18
Pin Adjust Gauge Wheel Leg Assembly.....	5-19
Dual Wheel Lift with 385/65R22.5 Tires.....	5-20
Dual Wheel Lift with 295/75R22.5 Tires.....	5-22
Single Wheel Lift Components	5-24
Hub and Spindle Components.....	5-26
Hub and Spindle Components.....	5-27
Hub and Spindle Components.....	5-28
Decals.....	5-29
Main Frame to Primary Wing Hydraulics.....	5-30
Main Frame Transport Wheel & Depth Control Hydraulics.....	5-32
Wing Gauge Wheel Hydraulics	5-34
Primary Wing to Secondary Wing Hydraulics	5-35
Secondary Wing Extension Hydraulics (52’ Units ONLY).....	5-36
Coulter Mounting Bracket Components.....	5-37
Offset Stagger Bracket & Bracket Extension.....	5-38
Super 1200 Flex Coulter Hub Assembly Components.....	5-40
Super 1200 Flex Coulter & Post Assembly.....	5-40
Super 1200 Flex Coulter Assembly Components.....	5-41
SealPro II & Blades.....	5-42
DiscCover Sealer.....	5-44
Disc Sealer Spring Add-On Kit Optional.....	5-46
Sealer Hanger with Blade Mounting.....	5-47
Row Clamp w/EdgeBent Shank & Coulter Mount.....	5-48
Shank Assembly 1 1/4” EdgeBent SCS Less Coulter.....	5-50
Row Clamp, 1 1/4” EdgeBent MaxPac.....	5-52
MaxPac Basket Mount Arm Components.....	5-53
MaxPac Mount with EdgeBent Shank Bundle.....	5-54
Coulter Bracket Extension 9 7/8” Kit.....	5-56
Coulter Bracket Extension 16 7/8” Kit.....	5-57
Torsion Arm Basket (Short Arms) Components.....	5-58
Torsion Arm/Rigid Basket Mounting Brackets.....	5-59
Basket Flat Mount with Hardware.....	5-60
Residue Manager Blade Mounting Assembly.....	5-61
StripTill Residue Manager Components.....	5-62
SuperShooter Hitch Assembly Components.....	5-64
SuperShooter Hitch, Low Mounting Components.....	5-66
Auto-Lok SuperShooter Hitch Components.....	5-67

(continued)

TABLE OF CONTENTS

SECTION V
Parts (continued)

SuperShooter III Connection Single 1.25" Plumbing.....5-68
SuperShooter III Connection Double 1.25" Plumbing.....5-70
SuperShooter III Components - 1.25" Connection.....5-72
SuperShooter III Single 1 1/4" Assembly.....5-74
SuperShooter III Max Single 1 1/2" Assembly.....5-75
SuperShooter III Connection Single 1.5" Plumbing.....5-76
SuperShooter III Connection Double 1.5" Plumbing.....5-78
SuperShooter III Components - 1.5" Connection.....5-80
Impellicone and Mounting Hardware - 2 Sec John Blue.....5-82
Impellicone and Mounting Hardware - 3 Sec John Blue.....5-84
Impellicone and Mounting Hardware - 4 Sec John Blue.....5-86
Manifold and Mounting Hardware - 2 Sec Continental.....5-88
Manifold and Mounting Hardware - 3 Sec Continental.....5-90
Manifold and Mounting Hardware - 4 Sec Continental.....5-92
Distribution 2-Section Hoses and Electrical.....5-94
Distribution 3-Section Hoses and Electrical.....5-96
Distribution 4-Section Hoses and Electrical.....5-98
1.5" Flow Control Valve.....5-100
1.0" Flow Control Valve (Optional).....5-102
Cooler - Vortex.....5-104
Cooler - Continental.....5-106
ISOBUS Rate Controller.....5-108
Raven 450 Rate Controller Option.....5-109
Lighting Components.....5-110

SECTION I
Safety

General Hazard Information 1-2
Safety Decals 1-3
Following Safety Instructions 1-6
Before Servicing 1-6
Before Operating 1-7
During Operation 1-7
Before Transporting 1-8
During Transport 1-8
Pressurized Oil 1-9
Chemical Hazards 1-9
Anhydrous Ammonia (NH₃) 1-10
Clean Water Tank 1-11
Preparing for Emergencies 1-11
Wearing Protective Equipment 1-11

General Hazard Information

No accident-prevention program can be successful without the wholehearted cooperation of the person who is directly responsible for the operation of the equipment.

A large number of accidents can be prevented only by the operator anticipating the result before the accident is caused and doing something about it. No power-driven equipment, whether it be transportation or processing, whether it be on the highway, in the field, or in the industrial plant, can be safer than the person who is at the controls. If accidents are to be prevented--and they can be prevented--it will be done by the operators who accept the full measure of their responsibility.

It is true that the designer, the manufacturer, and the safety engineer can help; and they will help, but their combined efforts can be wiped out by a single careless act of the operator.

It is said that, "the best kind of a safety device is a careful operator." We, at Unverferth Mfg. Co., Inc. ask that you be that kind of operator.



REMEMBER:
THINK SAFETY
A CAREFUL OPERATOR IS THE
BEST INSURANCE AGAINST AN
ACCIDENT!

SIGNAL WORDS



INDICATES AN EXTREMELY HAZARDOUS SITUATION OR ACTION THAT WILL RESULT IN SERIOUS INJURY OR DEATH.



INDICATES A HAZARDOUS SITUATION OR ACTION THAT COULD RESULT IN SERIOUS INJURY OR DEATH.



INDICATES AN UNSAFE SITUATION OR ACTION THAT MAY RESULT IN PERSONAL INJURY.



Is used for instruction on operating, adjusting, or servicing a machine.

Safety Decals

⚠ WARNING

- REPLACE LOST, DAMAGED, PAINTED, OR UNREADABLE DECALS IMMEDIATELY. IF PARTS THAT HAVE DECALS ARE REPLACED, ALSO MAKE SURE TO INSTALL NEW DECALS. THESE DECALS INFORM AND REMIND THE OPERATOR WITH OPERATIONAL INFORMATION AND SAFETY MESSAGES.

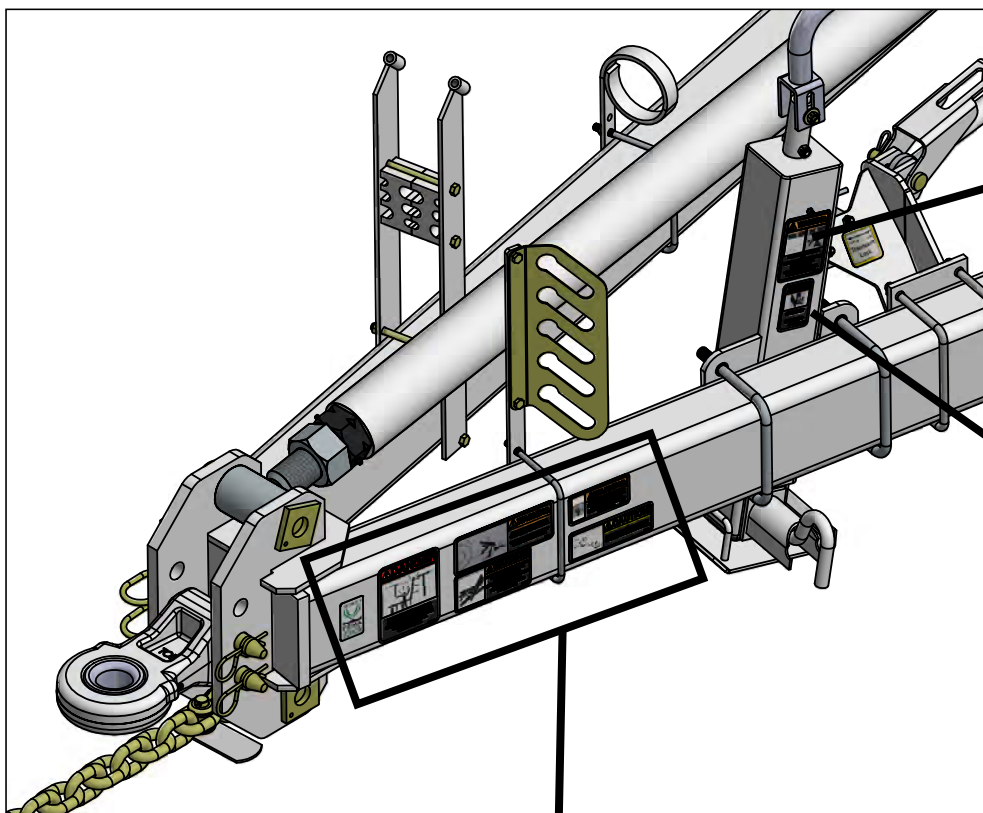

9501197



97048



90221



94094

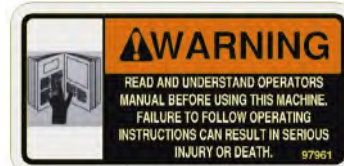

97961



95445



97575

(Continued)

Safety Decals (continued)

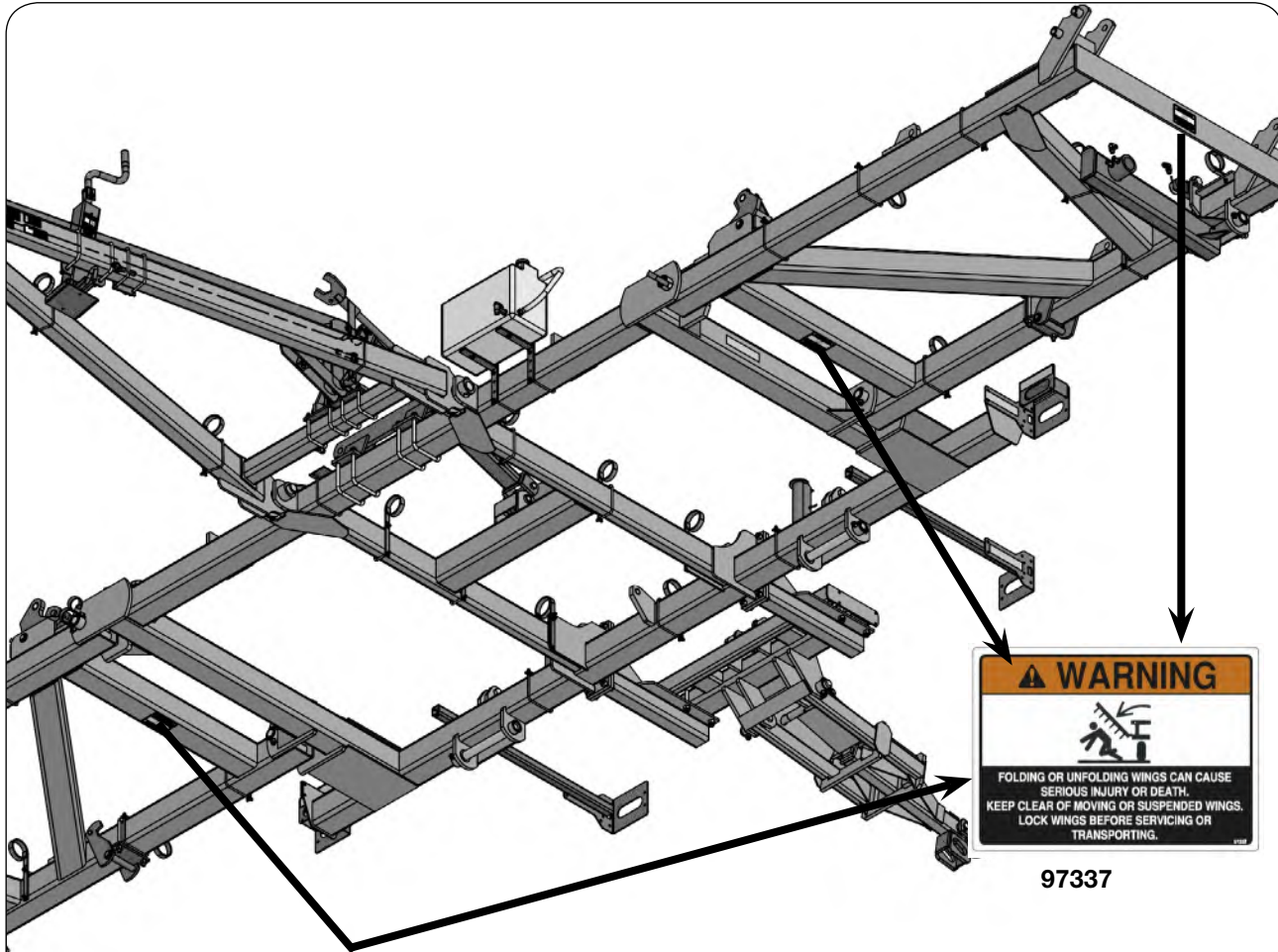

97337



9003125 - Fluorescent Strip



9003126 - Reflector RED



9003127 - Reflector AMBER

(Continued)

Safety Decals (continued)

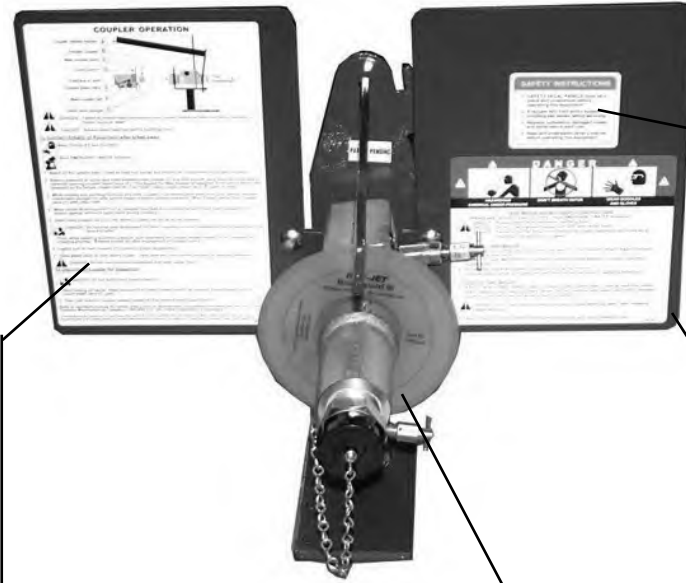

SAFETY INSTRUCTIONS

1. SAFETY DECAL PANELS must be in place and understood before operating this equipment.
2. Evacuate NH₃ from entire system, including ball valves, before servicing.
3. Replace outdated or damaged hoses and parts before each use.
4. Read and understand owner's manual before operating this equipment.

AP 2227

JAP227

HAZARDOUS CHEMICAL UNDER PRESSURE **DANGER** **DON'T BREATH VAPOR** **WEAR GOGGLES AND GLOVES**

TANK WAGON and NH₃ HOOK-UP INSTRUCTIONS

1. Always wear **GOGGLES** and **GLOVES**. Have **EMERGENCY WATER** available.
 - DANGER:** Always bleed feed-line before handling hose.
 - DANGER:** Do not road transport equipment with tank valves open.
 - DANGER:** Failure to follow these instructions may cause hazardous ammonia spray resulting in bodily injury or death.

TO CONNECT TANK WAGON:

2. Hitch wagon to toolbar using your hitch pin and hitch pin retainer. Attach wagon transport chains to toolbar hitch.
3. If Safety Coupler Male Half is not properly inserted, follow adjacent "Coupler Operation" instructions.
4. Screw hose and acme thread connection onto acme receiver.
5. Close all bleed valves and open tank and hose valves just prior to applying ammonia.

TO UNHOOK TANK WAGON:

6. Park on level surface. Refer to step 1. Stand on the upwind side. Close all feed-line valves; then, carefully open feed-line bleed valves. Do not continue until bleed valves have emptied.
7. Carefully unscrew hose and acme thread connection.
 - DANGER:** Do not carry hose by holding valve knob. Hose twist may open valve releasing trapped ammonia.
8. Store hose and secure wisely, avoiding improper hose and valve contact points.

AP 2973

JAP2973

COUPLER OPERATION

Check valve plunger (G)

DANGER: Failure to follow these instructions may cause hazardous ammonia spray resulting in bodily injury or death.

DANGER: Always bleed feed-line before handling hose.

To Connect Initially or Reconnect after break-away:

Wear **GOGGLES** and **GLOVES**.

Have **EMERGENCY WATER** available.

1. Stand on the upwind side. Close all feed-line valves and inspect all components for proper condition.
2. Relieve pressure in nurse tank hose between male coupler (F) and first shutoff valve towards nurse tank by carefully opening coupler bleed valve (E). The Squibs Flo-Max coupler is designed to re-couple safely with pressure on the female coupler half (B). **CAUTION:** Leave coupler bleed valve (E) open for now.
3. While holding and pointing the hose and male coupler (F) downwind and away from your person, depress check valve plunger (G) with gloved finger to ensure proper operation. Wipe foreign debris from coupler neck (C) with clean cloth.
4. Make certain BodyGuard III™ (D) is installed fully with slot oriented around check valve plunger (G) to protect against ammonia spray-back during coupling.
5. Insert male coupler neck (C) into female coupler half (B) as far as possible.
 - DANGER:** Do not look past BodyGuard (D) when coupling to avoid possible ammonia spray-back into face and eyes.
6. Then, while applying insertion pressure, pull downward on coupler release handle (A) to complete the coupling process. Release handle (A) after engagement of coupler neck (C).
7. Lightly pull on male coupler (F) to ensure proper engagement.
8. Close bleed valve (E) and others if open. Open tank and hose valves just prior to applying ammonia.
 - DANGER:** Do not road transport equipment with tank valves open.

To Disconnect coupler for inspection:

DANGER: Do not disconnect under pressure.

1. After closing all valves, bleed pressure from male coupler half (F) by opening coupler bleed valve (E). Leave bleed valve (E) open.
2. Then, pull down on coupler release handle (A) and remove male coupler half (F).

Refer to operators manual for further instruction on downstream components operation and service. Contact Thurston Manufacturing Company, 1-800-858-3127, for further information if necessary.

This decal is to be placed on all machines utilizing the SQUIBS FLO-MAX SuperShooter II Squibs Flo-Max Safety Coupler. SQUIBS-JET and SuperShooter III are Trade names of Thurston Manufacturing Company. Flo-Max is a Trade name of Squibs-Taylor 1-800-345-8105.





AP 2974

JAP2974



9503899 - 1 1/4" Connection
9503900 - 1 1/2" Connection

Following Safety Instructions

- Read and understand this operator's manual before operating. 
- All machinery should be operated only by trained and authorized personnel.
- To prevent machine damage, use only attachments and service parts approved by the manufacturer.
- Always shut tractor engine off and remove key before servicing. 
- Avoid personal attire such as loose fitting clothing, shoestrings, drawstrings, pants cuffs, long hair, etc., that may become entangled in moving parts.
- Do not allow anyone to ride on the implement. Make sure everyone is clear before operating machine or towing vehicle. 
- Never attempt to operate implement unless you are in driver's seat. 

Before Servicing

- Avoid working under an implement; however, if it becomes absolutely unavoidable, make sure the implement is safely blocked. 
- Ensure that all applicable safety decals are installed and legible.
- When working around the implement, be careful not to be cut by sharp edges.
- Explosive separation of a tire and rim can cause serious injury or death. Only properly trained personnel should attempt to service a tire and wheel assembly.
- Add sufficient ballast to tractor to maintain steering and braking control at all times. Do not exceed tractor's lift capacity or ballast capacity.
- Hitch applicator to towing vehicle and clear all personnel from the surrounding area before folding and unfolding wings.
- Check all applicator equipment for leaks. Repair any leaks before beginning or resuming operation.
- Residual pressure may exist in applicator plumbing even when unit is not in use. Remove pressure before servicing any plumbing.

Before Operating

- Do not stand between towing vehicle and implement during hitching.
- Always make certain everyone and everything is clear of the machine before beginning operation.
- Verify that all safety shields are in place and properly secured.
- Ensure that all applicable safety decals are installed and legible.
- When working around the implement, be careful not to be cut by sharp edges.
- Add sufficient ballast to tractor to maintain steering and braking control at all times. Do not exceed tractor's lift capacity or ballast capacity.
- Inspect fields for buried utility lines (electric, natural gas, water, etc.). To find buried lines in the US or Canada contact 1-888-258-0808, in the US you may also contact 811.
- This applicator is intended to apply only agricultural fertilizers. Attempting to apply other liquids may cause equipment damage and introduce unexpected personal hazards.
- Hitch applicator to towing vehicle and clear all personnel from the surrounding area before folding and unfolding wings.
- Residual pressure may exist in applicator plumbing even when unit is not in use. Remove pressure before servicing any plumbing.

During Operation

- Regulate speed to field conditions. Maintain complete control at all times.
- Never service or lubricate equipment when in operation.
- Keep away from overhead power lines. Electrical shock can cause serious injury or death.
- Use extreme care when operating close to ditches, fences, or on hillsides.
- Do not leave towing vehicle unattended with engine running.

Before Transporting

- Secure transport chains to towing vehicle before transporting. **DO NOT** transport without chains.
- Install transport locks before transporting.
- Check for proper function of all available transport lights. Make sure that all reflectors are clean and in place on machine. Make sure that the SMV emblem and SIS decal are visible to approaching traffic.
- This implement may not be equipped with brakes. Ensure that the towing vehicle has adequate weight and braking capacity to tow this unit.

During Transport

- Comply with all laws governing highway safety when moving machinery.
- Use transport lights as required by all laws to adequately warn operators of other vehicles.
- Use good judgment when transporting equipment on highways. Regulate speed to road conditions and maintain complete control.
- Maximum speed of implement should never exceed 20 mph. Do not exceed 10 mph during off-highway travel.
- Slow down before making sharp turns to avoid tipping. Drive slowly over rough ground and side slopes.
- It is probable that this implement is taller, wider and longer than the towing vehicle. Become aware of and avoid all obstacles and hazards in the travel path of the equipment, such as power lines, ditches, etc.

Pressurized Oil

- Relieve pressure before disconnecting hydraulic lines, loosening any hydraulic fittings or servicing hydraulic system. See the maintenance section of this manual for the procedure to relieve pressure.
- High-pressure fluids can penetrate the skin and cause serious injury or death. Use cardboard or wood to detect leaks in the hydraulic system. Seek medical treatment immediately if injured by high-pressure fluids. 
- Hydraulic system must be purged of air before operating to prevent serious injury or death.
- Do not bend or strike high-pressure lines. Do not install bent or damaged tubes or hoses.
- Repair all oil leaks. Leaks can cause fires, personal injury, and environmental damage.
- Route hoses and lines carefully to prevent premature failure due to kinking and rubbing against other parts. Make sure that all clamps, guards and shields are installed correctly.
- Check hydraulic hoses and tubes carefully. Replace components as necessary if any of the following conditions are found:
 - End fittings damaged, displaced, or leaking.
 - Outer covering chafed/cut or wire reinforcing exposed.
 - Outer covering ballooning locally.
 - Evidence of kinking or crushing of the flexible part of a hose.

Chemical Hazards

- Always wear personal protective equipment when working with or near chemicals. This equipment includes, but is not limited to: protective eye wear, gloves, shoes, socks, long-sleeved shirt, and long pants. Additional protection may be required for many types of chemicals.
- Seek and receive chemical product training prior to using agricultural chemicals.
- Read and understand the entire label of every chemical being applied with this sprayer.
- Avoid breathing spray mist or vapor.
- Wash hands and exposed skin immediately after contact with spray/fertilizer solution and application equipment.
- Remove clothing immediately if chemicals penetrate clothing and contact skin. Wash thoroughly and put on clean clothing.
- Dispose of unused chemical in accordance with chemical label directions and local/national regulations.



Anhydrous Ammonia (NH₃)

- Exposure to anhydrous ammonia (NH₃) will cause serious injury or death. Anhydrous ammonia causes severe burns to the eyes, skin, and respiratory system. Immediately flush exposed areas with fresh water and seek medical treatment.
- It is important that all personnel understand the properties of anhydrous ammonia, and that they be thoroughly trained in safe practices for its storage, transferring, transporting, and otherwise handling. Train all personnel in safe operating practices and take appropriate actions in the event of a leak or an emergency. Consult proper authorities for anhydrous ammonia training and documentation.
- Pressure gauges can fail or plug. Do not rely on gauge readings to indicate presence of anhydrous ammonia in a system. Treat all plumbing sections as if anhydrous ammonia is present. See [operating/maintenance] section for proper bleeding procedures.
- Liquid anhydrous ammonia trapped in the plumbing can absorb heat from surroundings and unexpectedly pressurize the system.
- Never unhitch the anhydrous ammonia applicator from the tractor with a nurse tank attached.
- Always park applicator downwind from the operating station, other personnel, livestock, and nearby buildings before attempting to connect or disconnect tank hosing.
- Always remain upwind when depressurizing the system.
- Inspect all anhydrous ammonia valves, couplers, hoses, and other plumbing equipment prior to usage or storage. Repair or replace any component showing wear, damage, or as required per date stamp and manufacturer's instructions.
- When coupling a nurse tank and supply hose to the applicator for the first time, perform a test turn in both directions with the tank valve closed to verify sufficient slack in the hose allows free articulation. Do not allow hose to contact the wagon tongue or any other component during movement.
- In the event of a breakaway coupling device disconnection, inspect the breakaway device and all supporting structures and plumbing before resetting the coupler. Understand why the disconnection occurred and take action to limit reoccurrence.
- Immediately evacuate the area in the event of an anhydrous ammonia leak or accidental release. Prevent others from entering the area of the anhydrous ammonia leak.
- Ensure a readily accessible clean water tank with a minimum of 5 gallons of fresh water are available for first aid use.
- Always wear personnel protective equipment (PPE) when working with or near anhydrous ammonia. This equipment includes, but is not limited to:
 - Protective gauntlet style gloves impervious to anhydrous ammonia
 - Indirect vent chemical splash goggle
 - Shoes and socks
 - Long sleeved shirt
 - Long pants
 - A full-face shield is appropriate, but does not replace the need for the chemical splash goggles.
- Only open a nurse tank valve during application. Do not transport, park, or leave the applicator unattended with the valve open.





Clean Water Tank

- A clean water tank is provided as standard equipment. It is equipped with a spigot for general washing and a hose for emergency eye washing.
- Always keep clean water in tank. Water in clean water tank is not suitable for human consumption.
- For emergency eyewash, pull hose off of the top fitting and flush affected area.

Preparing for Emergencies

- Keep a first aid kit and properly rated fire extinguisher nearby.  
- Keep emergency numbers for fire, rescue, and poison control personnel near the phone. 
- A clean water tank is provided as standard equipment. It is equipped with a spigot for general washing and a hose for emergency eye washing.
- Always keep clean water in tank. Water in clean water tank is not suitable for human consumption.
- For emergency eyewash, pull hose off of top fitting and flush affected area.

Wearing Protective Equipment

- Wear clothing and personal protective equipment appropriate for the job.  
- Wear steel-toed shoes when operating. 
- Wear hearing protection when exposed to loud noises. 
- Do not wear additional hearing impairing devices such as radio headphones, etc.



Notes

SECTION II

Set Up

Set Up	2-2
Tongue Assembly to Main Frame Assembly	2-3
Attaching Depth Stop and Routing Hoses	2-5
Nurse Tank Hitch Assembly.....	2-6
Transport Lighting Assembly.....	2-7
SMV Assembly	2-9
Mounting Offset Stagger & Double Extension Brackets	2-10
Sealer II Assembly (JAAM2857) - Optional Sealer II Spring Add-On Kit.....	2-11
Torsion Arm Assembly	2-12
Attaching Bearings and Basket to Mounting Arms	2-12
Position Basket on Torsion Spring Assembly.....	2-12
Center Basket.....	2-13
Attaching Torsion Arm Assembly to MaxPac Basket Mount Arm.....	2-13
Attaching Torsion Arm Assembly to 6"x6" Tube (JAAM2630).....	2-14
MaxPac AR700 Assembly	2-15
Residue Manager Assembly.....	2-16
Legacy 38' and 42' Toolbars.....	2-17
Legacy 47' and 52' Toolbars.....	2-18
Overhead Layouts - Legacy.....	2-19
Overhead Layouts - Legacy SD	2-33
Raven RCM Guide	2-39

Set Up

WARNING

- **READ AND UNDERSTAND SAFETY RULES BEFORE OPERATING OR SERVICING THIS MACHINE. REVIEW THE SAFETY SECTION IN THIS MANUAL IF NECESSARY.**

- **TIPPING OR MOVEMENT OF THE MACHINE CAN CAUSE SERIOUS INJURY OR DEATH. BE SURE THE MACHINE IS SECURELY BLOCKED.**

- **KEEP HANDS CLEAR OF PINCH POINT AREAS.**

- **FALLING OBJECTS CAN CAUSE SERIOUS INJURY OR DEATH. DO NOT WORK UNDER THE MACHINE AT ANY TIME WHILE BEING HOISTED. BE SURE ALL LIFTING DEVICES AND SUPPORTS ARE RATED FOR THE LOADS BEING HOISTED. THESE ASSEMBLY INSTRUCTIONS WILL REQUIRE SAFE LIFTING DEVICES UP TO 7,000 LBS. SPECIFIC LOAD RATINGS FOR INDIVIDUAL LOADS WILL BE GIVEN AT THE APPROPRIATE TIME IN THE INSTRUCTIONS.**

- **EYE PROTECTION AND OTHER APPROPRIATE PERSONAL PROTECTIVE EQUIPMENT MUST BE WORN WHILE SERVICING THE IMPLEMENT.**

For your safety, and the safety of others, use proper tools and equipment and always use safe working procedures. Refer to these instructions before starting any work on the machine.

For ease of assembly, install all hardware loosely until assembly is complete and then tighten according to Torque Chart in the MAINTENANCE section of this manual.

NOTE: Supply hose kits are available. Contact your Blu-Jet dealer for details.

Tongue Assembly to Main Frame Assembly

1. Using a safe lifting device rated for at least 2,000 lbs., secure tongue assembly to main frame with 2" Dia. x 10 1/4" pins (JBM3565), 5/8"-11UNC x 4" capscrews (9390-132), and 5/8"-11UNC elastic lock nuts (9398-019). (FIG. 2-1)

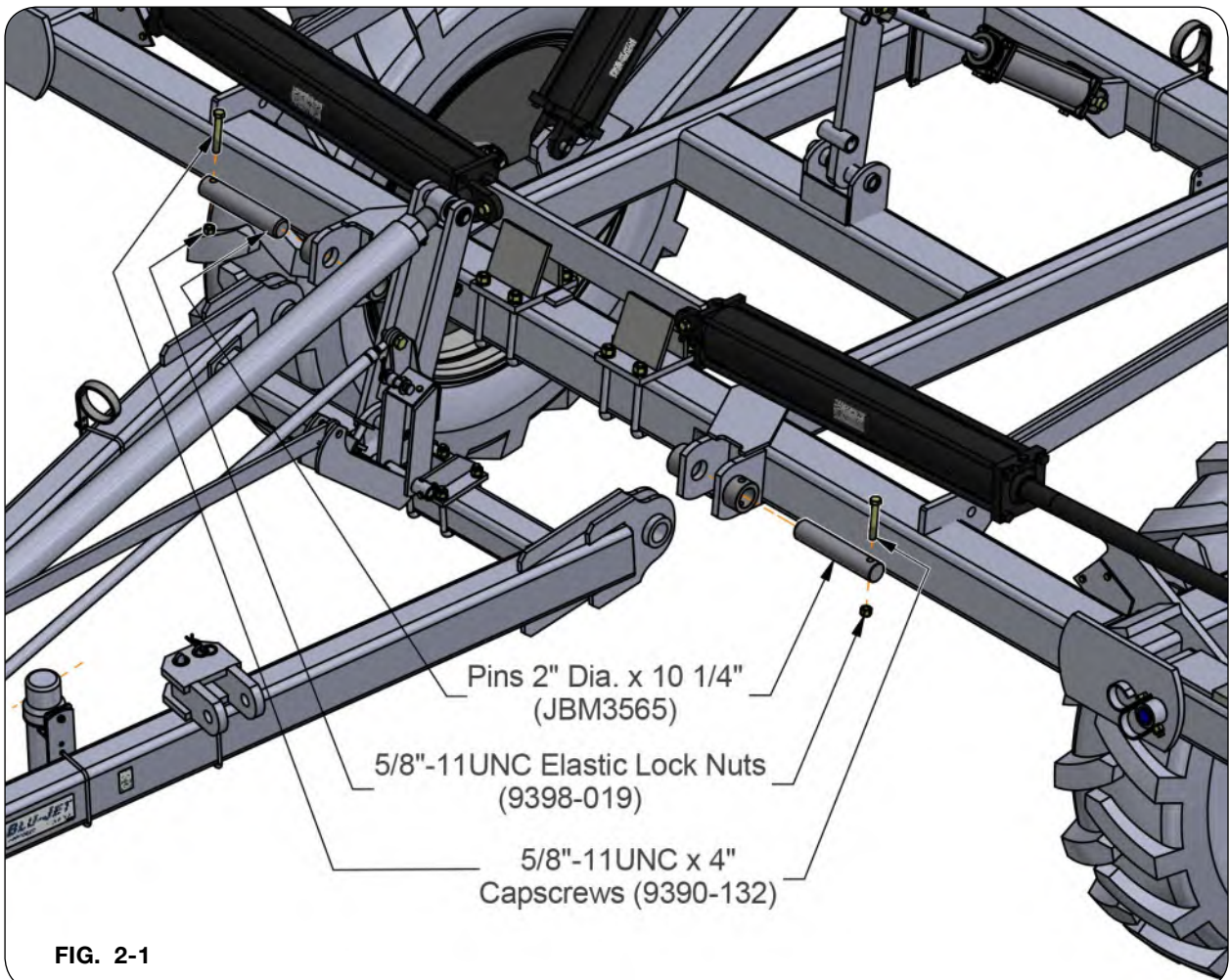

Tongue Assembly to Main Frame Assembly (continued)

2. Rotate tongue cylinder linkage (JAM6183) to the tongue cylinder arm linkage (JAM6182). Secure with 1 1/4" Dia. x 7 3/4" pin (JBM3465), 3/8"-16UNC x 2 1/2" capscrew (9390-061) and 3/8"-16UNC lock nut (902875) (FIG. 2-2).

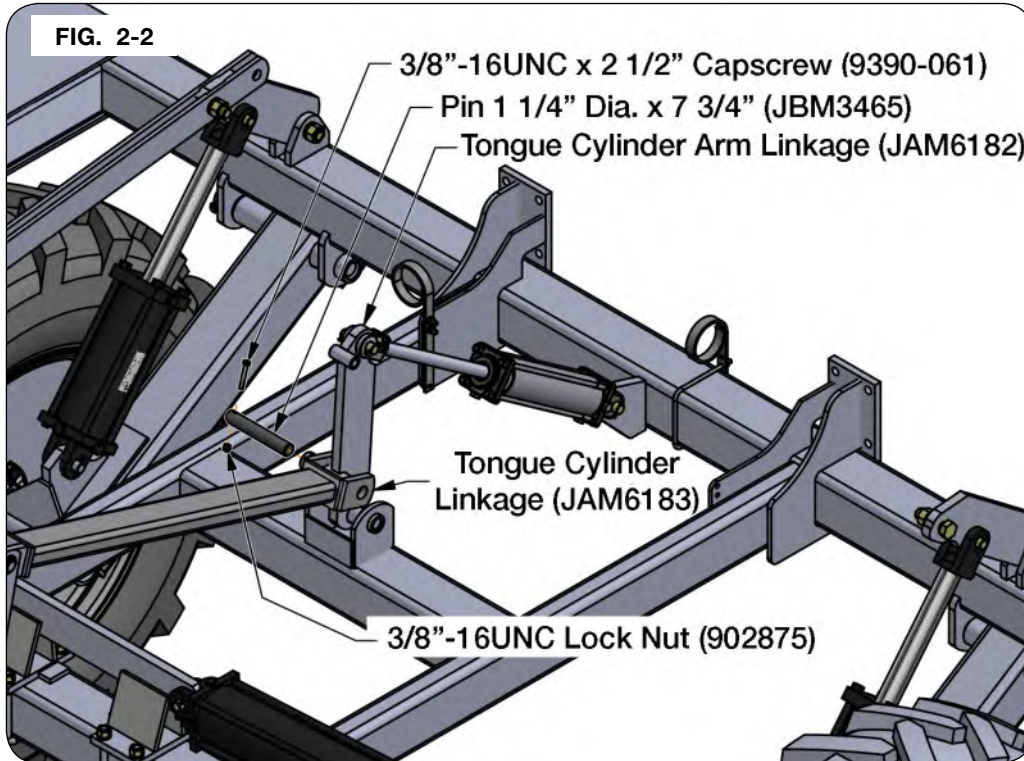

3. Rotate linkage stop weldment (JAM6266) to the tongue cylinder arm linkage (JAM6182). Secure with 3/4"-10UNC x 4" capscrew (9390-153) and 3/4"-10UNC lock nut (96732) (FIG. 2-3).

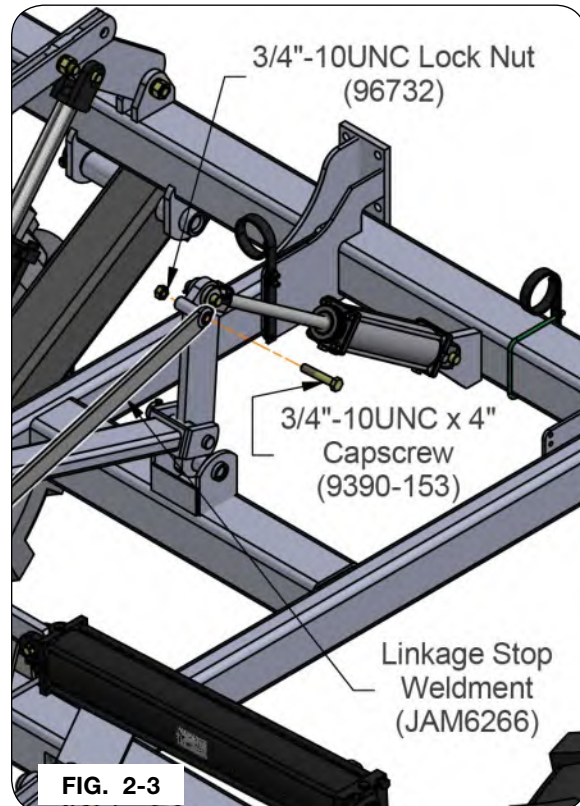

Attaching Depth Stop and Routing Hoses

1. Bolt the depth stop to the main frame. (FIG. 2-4)

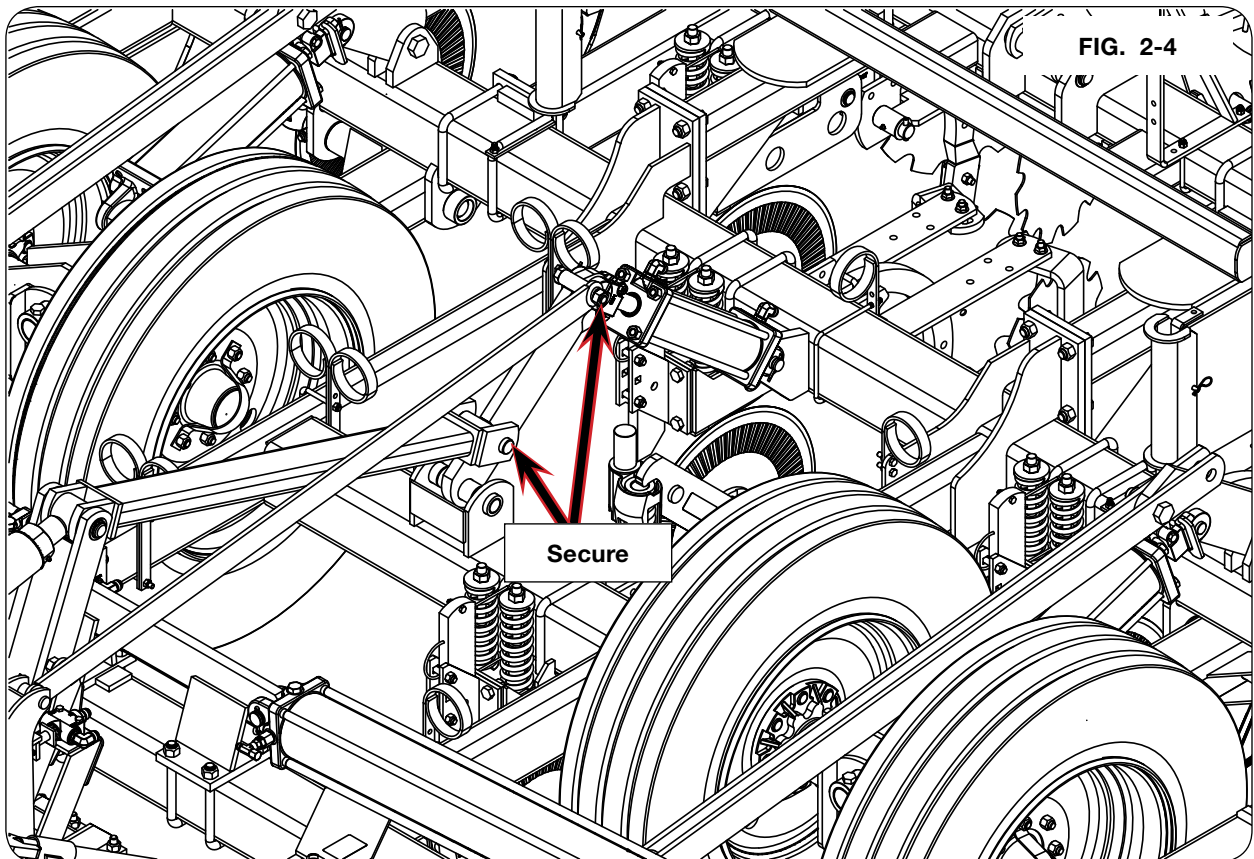

2. Route hoses along the right side of the tongue. (FIG. 2-5)

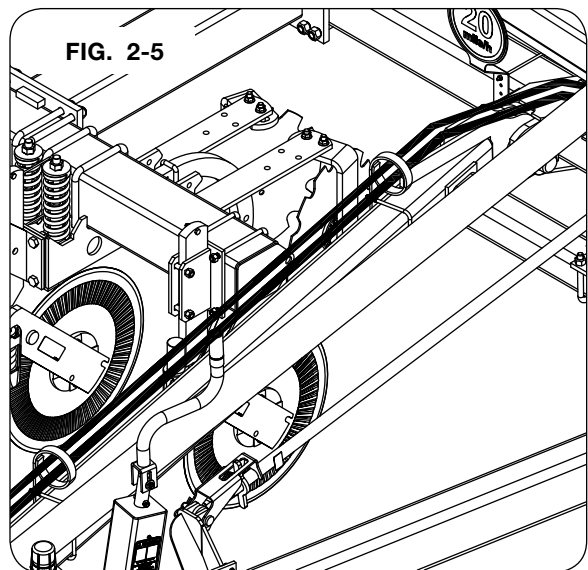

Nurse Tank Hitch Assembly

1. Using a safe lifting device rated at a minimum of 1000 lbs., attach the nurse tank hitch assembly to the main frame with twelve 3/4"-10UNC x 2 1/2" capscrews (9390-147) and 3/4"-10UNC lock nuts (97025). (FIG. 2-6 or FIG. 2-7)

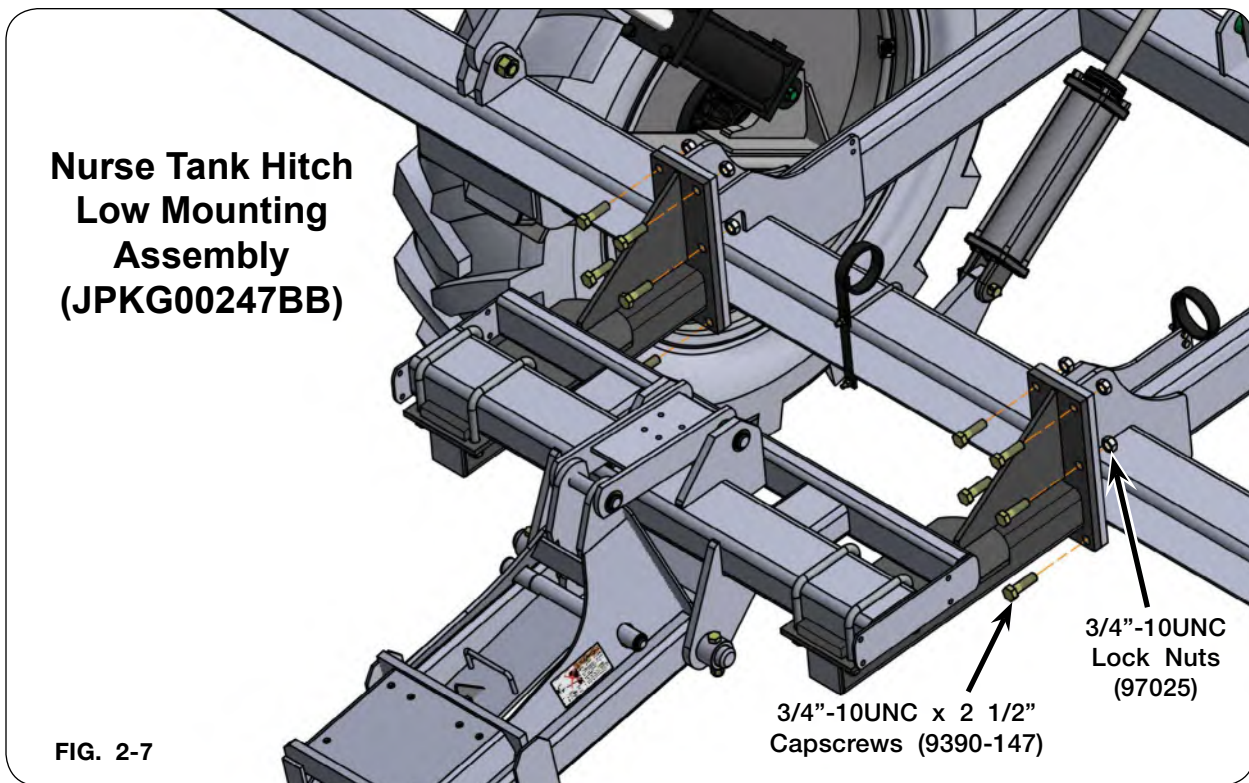
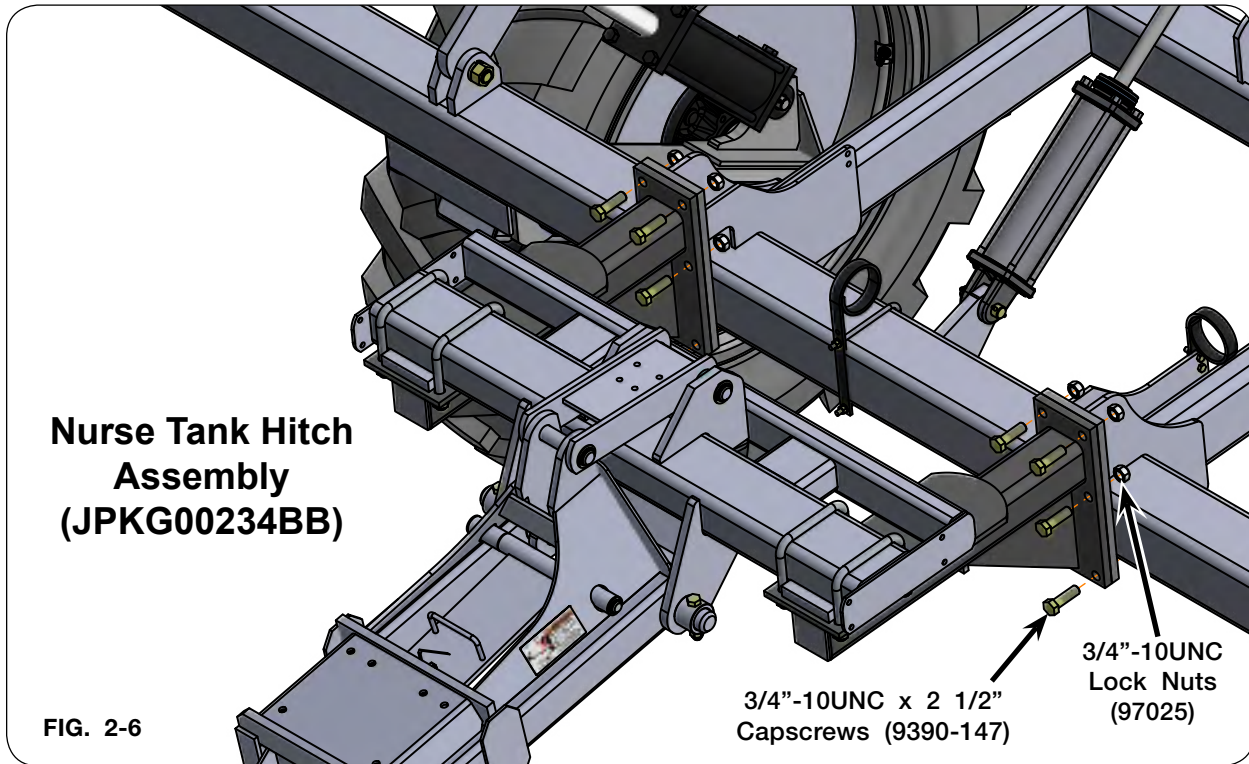

Transport Lighting Assembly

Compliance with all lighting and marking laws is the responsibility of the operator at the time of travel.

See federal regulation 49 CFR 562; available at www.govinfo.gov for US federal law requirements.

See your Unverferth dealer for additional brackets, reflectors, or lights to meet your requirements.

NOTE: Consult row spacing layout for light kit placement.

Nurse tank hitch light kit placement for Legacy 42 ft. and Legacy 47 ft. (FIG. 2-14)

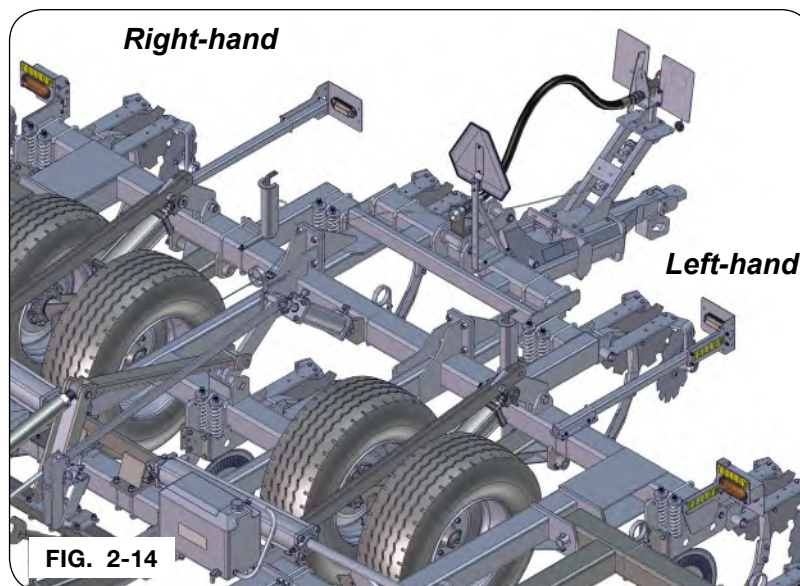

Nurse tank hitch light kit placement for Legacy 52 ft. (FIG. 2-15)

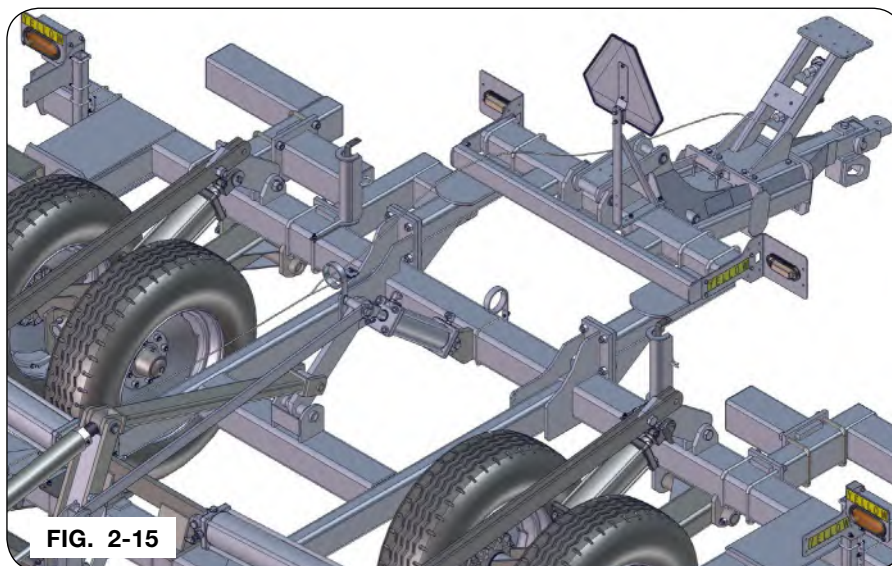

Transport Lighting Assembly (continued)

1. Rear electrical wiring harness (JAP3222) is extended down the right-hand side of the tongue through hose holders to dust cap.
2. Attach electrical wiring harness extension (JAP3222) to electrical plug and socket harness (JAP3221). (FIG. 2-22)

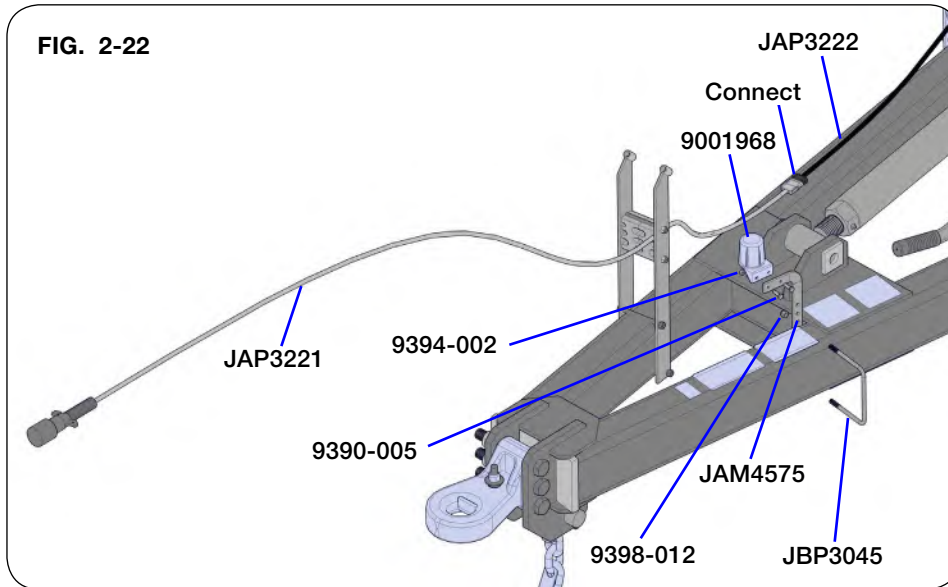

SMV Assembly

1. Mount SMV mounting bracket (JAM3420) near the center of the rear bar with 3/8"-16UNC x 5" x 6 7/16" U-bolt (JBP3045) and 3/8"-16UNC elastic lock nuts (9398-012). (FIG. 2-23)
2. Attach spade (TA510516) to SMV sign (TA510514) with hardware supplied. (FIG. 2-23)
3. Secure to socket (TA510515) with hardware provided. (FIG. 2-23 & FIG. 2-24)

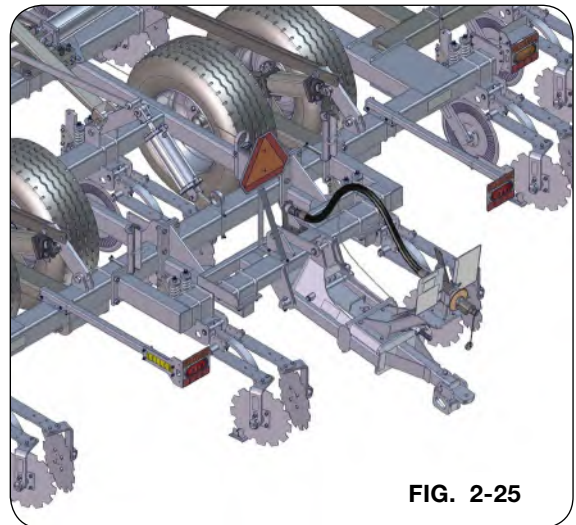
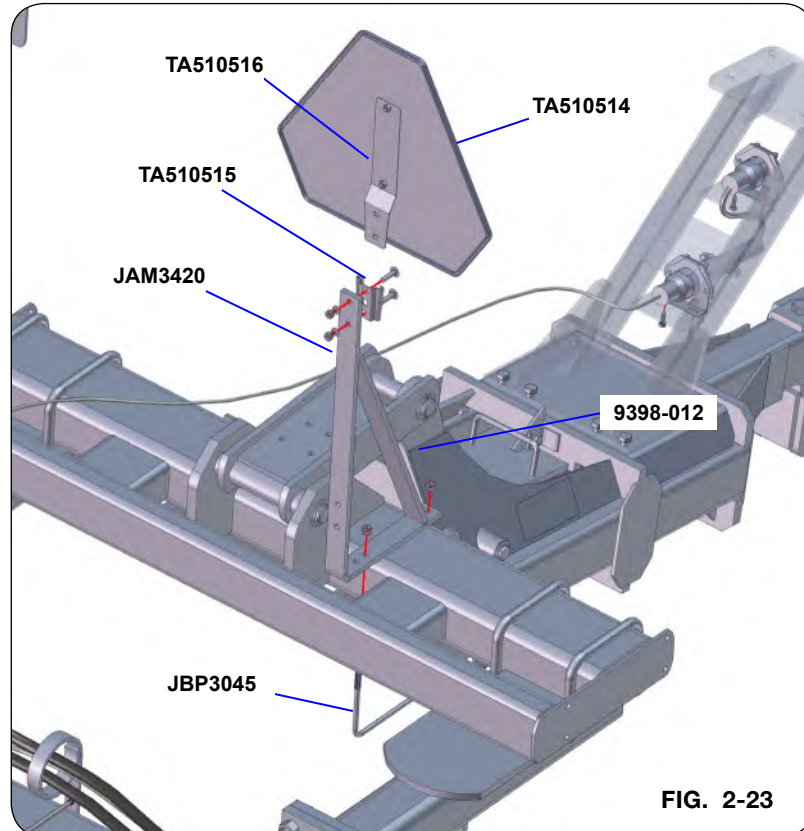

Mounting Offset Stagger & Double Extension Brackets

NOTE: For proper positioning, refer to “Overhead Layouts”, in SET UP section.

- Using a safe lifting device rated for at least 100 lbs., attach 6” x 6” mounting offset stagger brackets (JAM4545BB) with 3/4”-10UNC x 6”W x 7 1/16”L U-bolts (JBP3350), and 3/4”-10UNC lock nuts (9802). (FIG. 2-28 & FIG. 2-29)

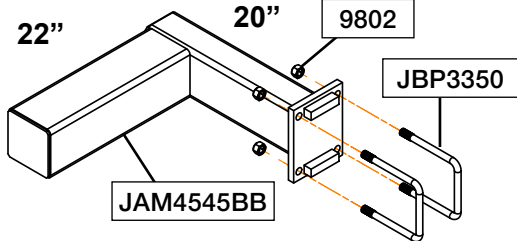

Offset Stagger Bracket Assembly
 (JAM4545BB)
 FIG. 2-28

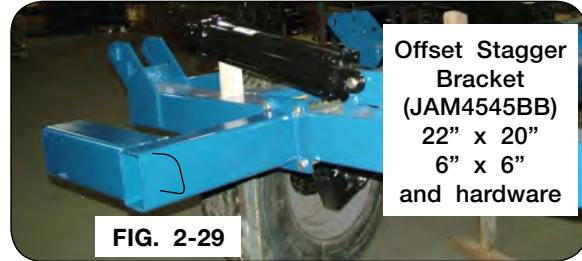

FIG. 2-29

- Attach 35” double extension bracket (JAM6161BB) 6” x 6” mounting to frame with four 3/4”-10UNC x 6”W x 7 1/16”L u-bolts (JBP3350), and 3/4”-10UNC lock nuts (9802).
- Mount 35” extension bracket (JAM6160BB) to 35” double extension bracket (JAM6161BB) with four 3/4”-10UNC x 6”W x 7 1/16”L u-bolts (JBP3350), and 3/4”-10UNC lock nuts (9394-016).

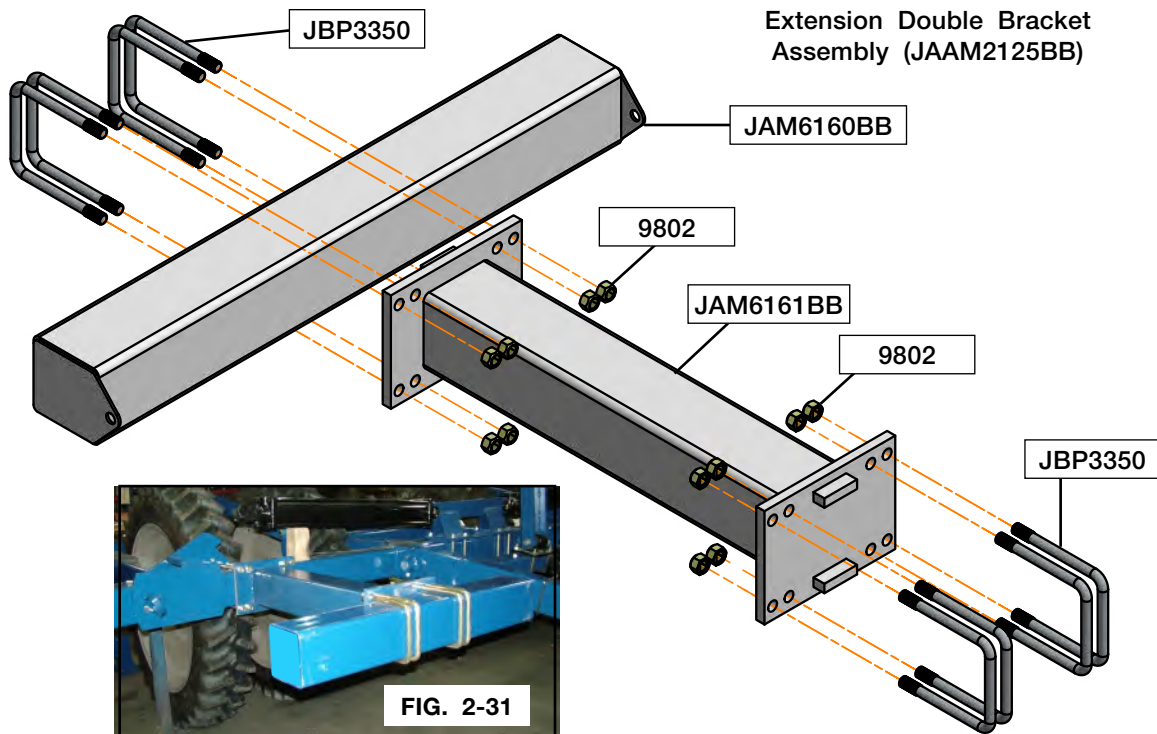
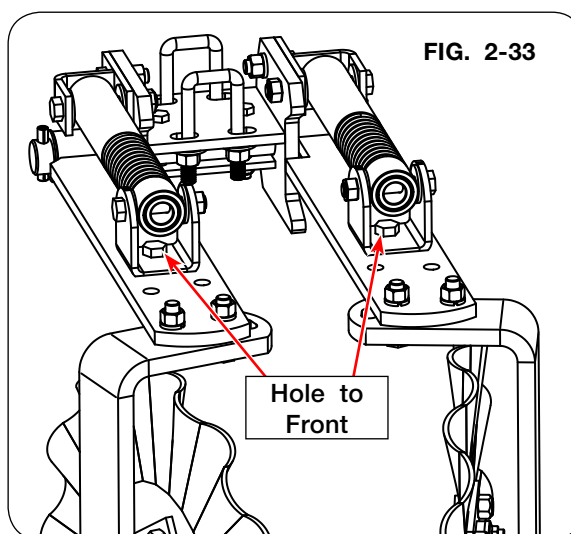
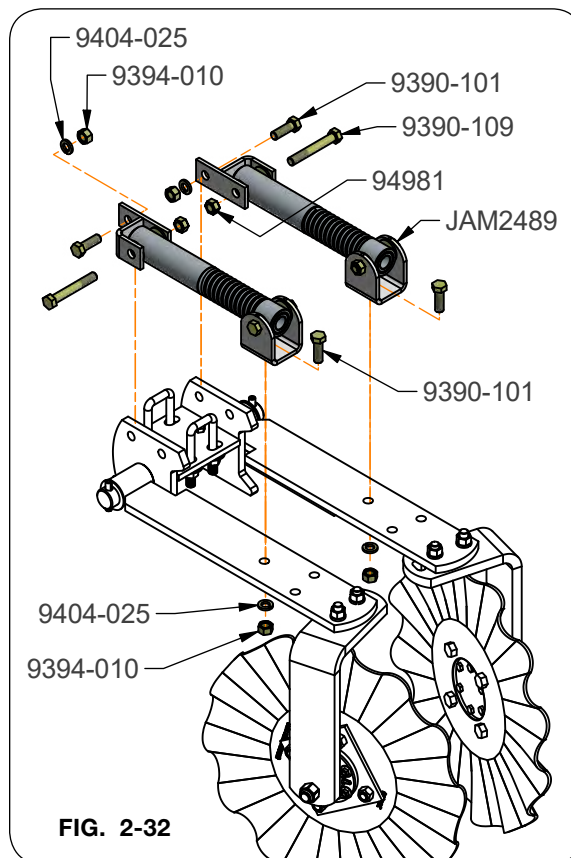

FIG. 2-30

FIG. 2-31

Sealer II Assembly (JAAM2857)
Optional Sealer II Spring Add-On Kit 1 Row

1. Remove the 1/2"-13UNC x 1 1/2" capscrews (9390-101), 1/2" lock washer (9404-025) and 1/2"-13UNC hex nut (9394-010) from the lower clevis (JAM2489) (FIG. 2-32).
2. Mount the sealer spring clevis lower (JAM2489) to arm with clevis hole to the front (FIG. 2-33). Loosely attach with 1/2"-13UNC x 1 1/2" capscrews (9390-101), 1/2" lock washer (9404-025) and 1/2"-13UNC hex nut (9394-010).
3. Remove the 1/2"-13UNC x 1 1/2" capscrew (9390-101), 1/2" lock washer (9404-025) and 1/2"-13UNC hex nut (9394-010) from the clevis weldment end of the sealer spring add-on kit.
4. Remove the 1/2"-13UNC x 3 1/2" capscrew (9390-109) and 1/2"-13UNC lock nut (94981) from the upper spring of the sealer spring add-on kit.
5. Mount the clevis weldment end of the sealer add-on kit to the sealer mounting bracket assembly loosely with 1/2"-13UNC x 1 1/2" capscrew (9390-101), 1/2" lock washer (9404-025) and 1/2"-13UNC hex nut (9394-010). (FIG. 2-32)
6. Loosely attach the upper spring of the sealer spring add-on kit to the sealer mounting bracket assembly with 1/2"-13UNC x 3 1/2" capscrew (9390-109) and 1/2"-13UNC lock nut (94981). (FIG. 2-32)
7. Secure hardware, but do not over tighten hardware. Allow tubes to pivot.



Torsion Arm Assembly

Attaching Bearings and Basket to Mounting Arms

1. Loosely attach bearing (JAP2144) on strip-till basket mount arm (JAM2269), with 7/16"-14UNC x 1 1/2" capscrews (9390-080), 7/16" lock washers (9404-023), and 7/16"-14UNC hex nuts (9394-008). (FIG. 2-39)

NOTE: Do not tighten hex nuts until the basket is installed.

2. Insert 1"-8UNC x 2 1/2" capscrew (9390-185) into both bearing arm assemblies (FIG. 2-39).

NOTE: Bearing lock collars not used.

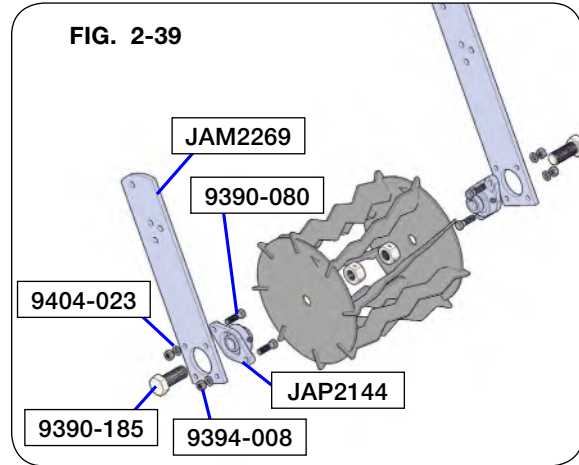

Position Basket on Torsion Spring Assembly

1. Insert strip-till basket (JAM7615), over 1"-8UNC x 2 1/2" capscrew (9390-185) (FIG. 2-40). Install 1"-8UNC lock nut (92199). Tighten hardware according to Torque Chart in MAINTENANCE section.

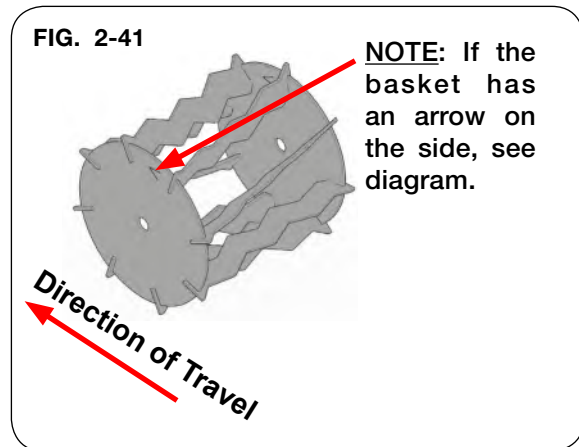
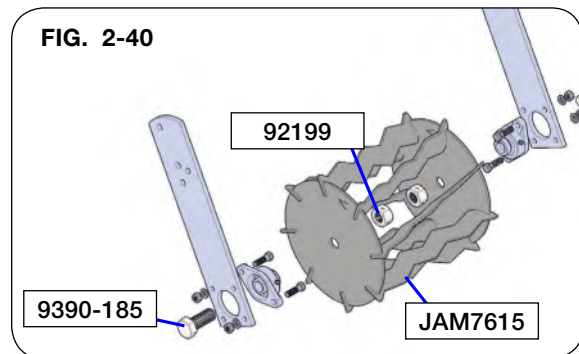

Torsion Arm Assembly (continued)

Center Basket

1. Position StripTill basket assembly on torsion spring assembly (FIG. 2-42). Insert 1/2"-13UNC x 1 1/2" capscrews (9390-101), top and bottom. Secure top pivot hex cap screws with 1/2" lock nuts (94981). Secure lower adjustable capscrews with 1/2" lock washers (9404-025) and 1/2"-13UNC hex nuts (9394-010). Tighten hardware according to Torque Chart in MAINTENANCE section.

NOTE: Insert the basket arms to the inside of the StripTill torsion spring (JAM7568).

(Diagram shows a starting position.)

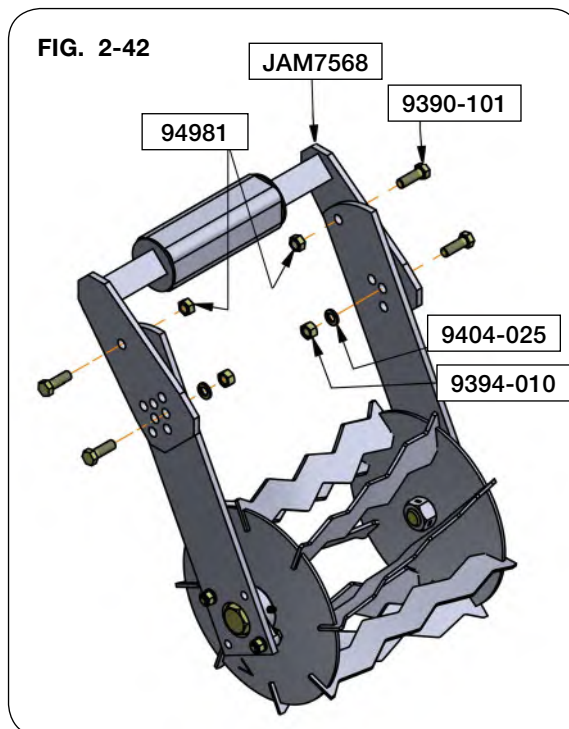

Attaching Torsion Arm Assembly To MaxPac Basket Mount Arm

1. Attach torsion arm assembly (J70210641), to MaxPac basket mount arm with 5/8"-11UNC x 2 1/2" x 4" U-bolts (JBP3300), 5/8" lock washers (9404-029), and 5/8"-11UNC hex nuts (9394-014) (FIG. 2-43).

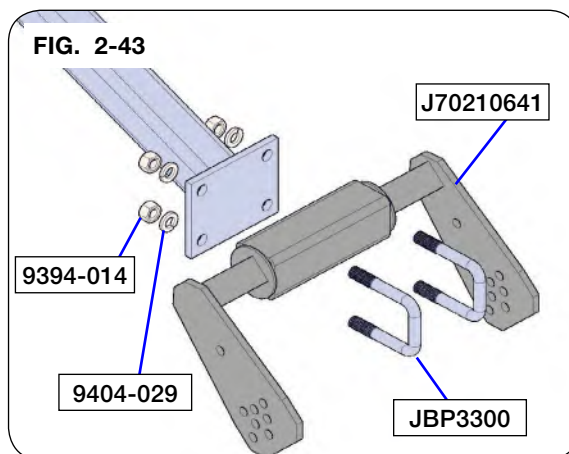

Torsion Arm Assembly (continued)

**Attaching Torsion Arm Assembly To 6"x6" Tube
(Bundle #JAAM2630)**

1. Center and attach torsion arm assembly (J70210641), to the basket mount plate (JAM7637) with 5/8"-11UNC x 2 1/2"W x 4"L U-bolts (JBP3300), 5/8" lock washers (9404-029), and 5/8"-11UNC hex nuts (9394-014) as shown below. Tighten hardware according to Torque Chart in MAINTENANCE section.

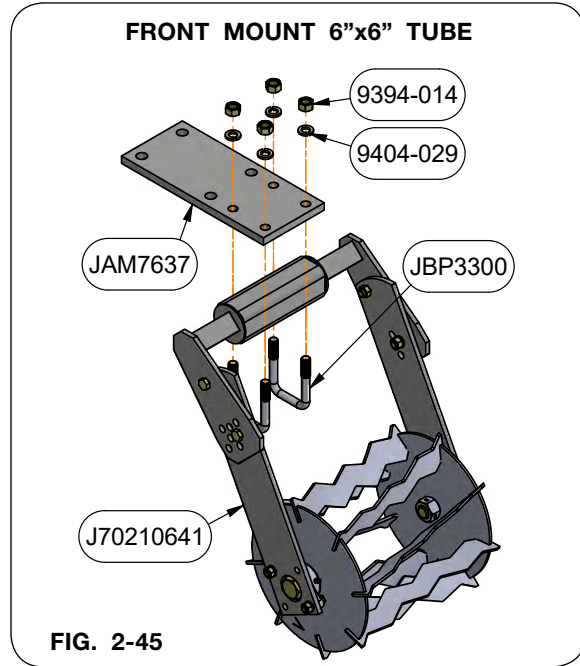

2. Using a safe lifting device rated at a minimum of 100 lbs., secure the basket mount plate to the rear or front mount 6"x6" tube with two 3/4"-10UNC x 6"W x 7 11/16"L U-bolts (JBP3350), four 3/4" lock washers (9404-033), and four 3/4"-10UNC hex nuts (9394-016). Torque hardware.

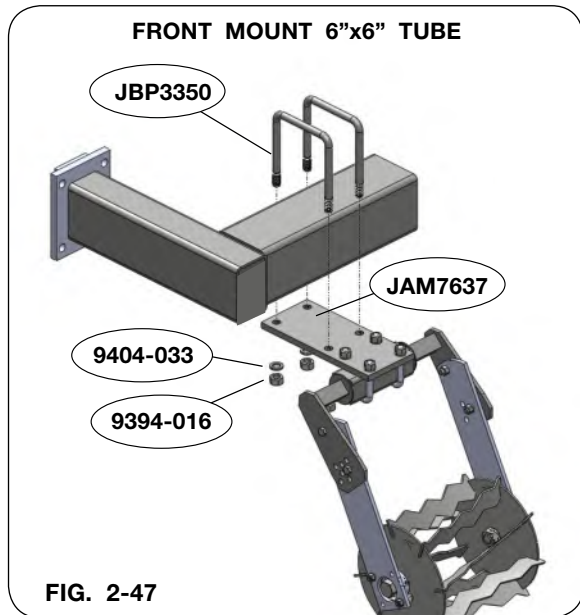

MaxPac AR700 Assembly

1. Using a safe lifting device rated at a minimum of 150 lbs., secure MaxPac row unit (JAM2264) with 1 1/4" x 2" EdgeBent shank (JAP2125) with backing plate (JAM2262), 3/4"-10UNC x 8" capscrews (9390-161) 3/4" lock washers (9404-033), and 3/4"-10UNC hex nuts (9394-016). (FIG. 2-52)

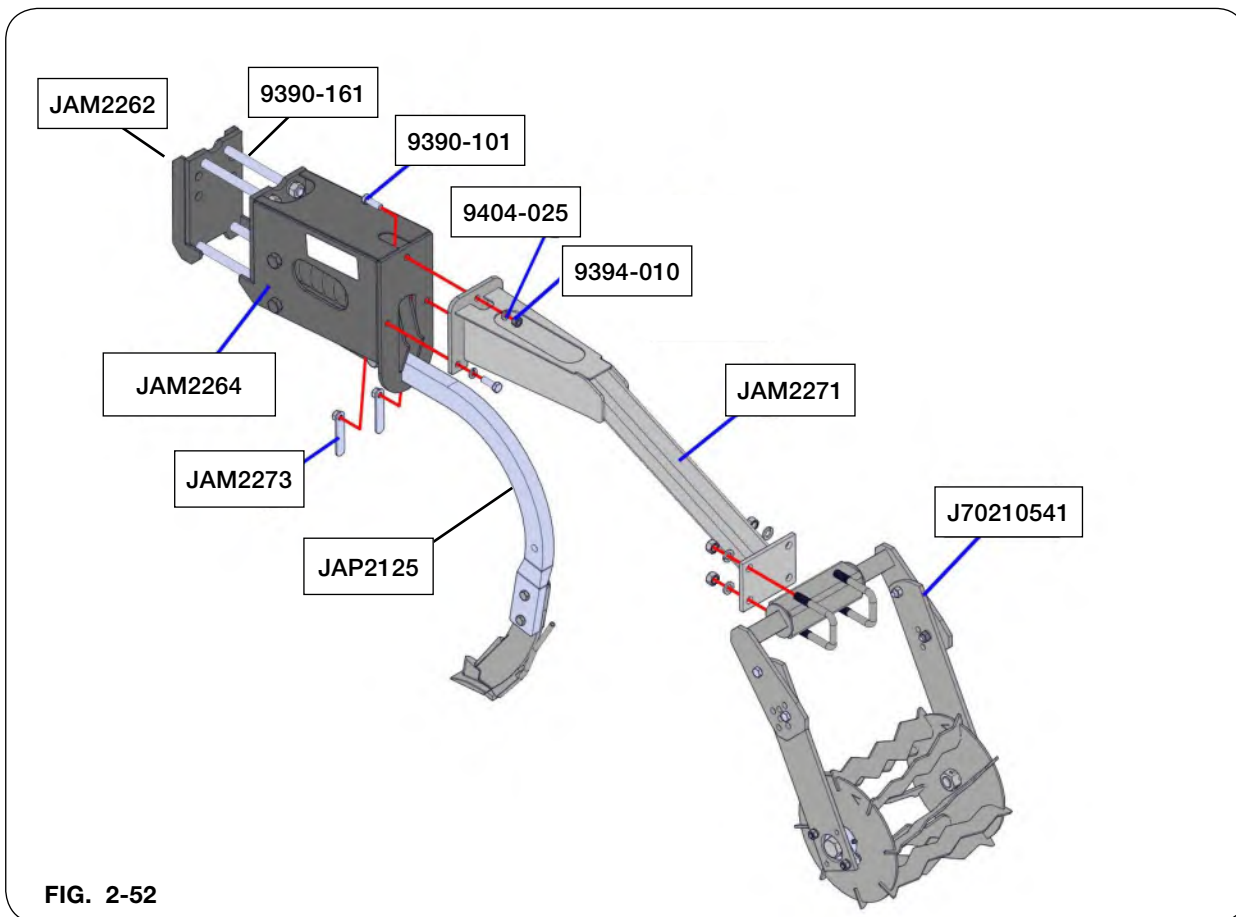

FIG. 2-52

2. Using a safe lifting device rated at a minimum of 100 lbs., secure MaxPac basket mount weldment (JAM2271) and torsion arm assembly (J70210641) to the MaxPac row unit (JAM2264) with two nut plate weldments (JAM2273), one 1/2"-13UNC hex nut (9394-010), three 1/2" lock washers (9404-025), and three 1/2"-13UNC x 1 1/2" capscrews (9390-101). (FIG. 2-52)
3. Tighten hardware according to Torque Chart in the MAINTENANCE section of this manual.

Residue Manager Assembly

Refer to Residue Manager manual #J0400023 for specific Set Up instructions.



Legacy 38' and 42', Toolbars

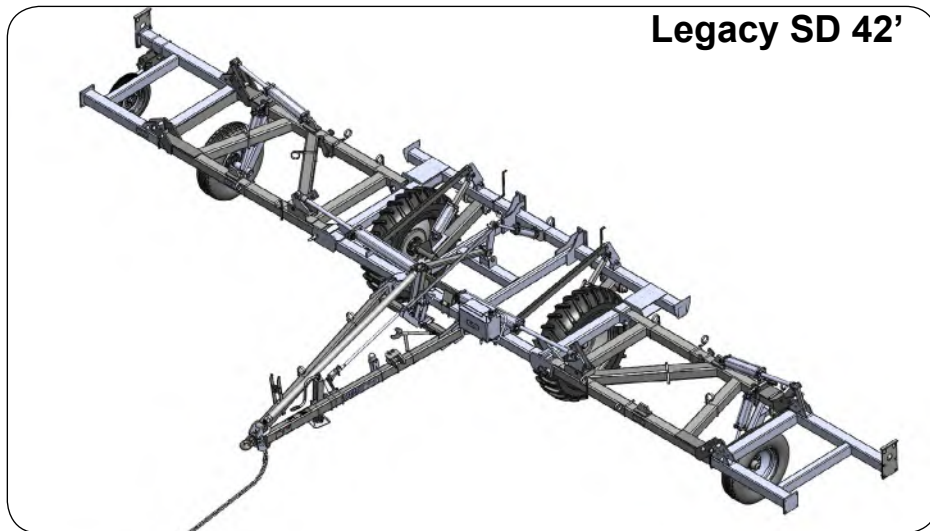
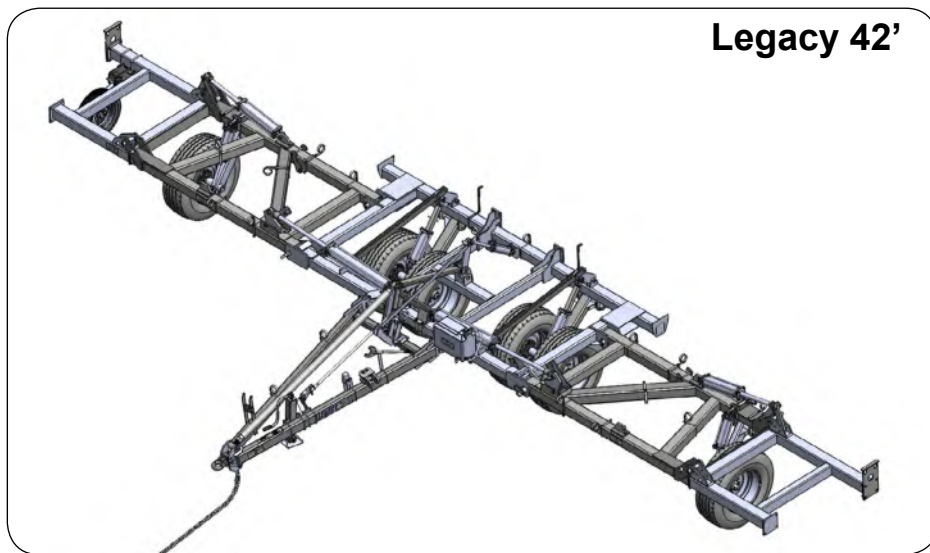
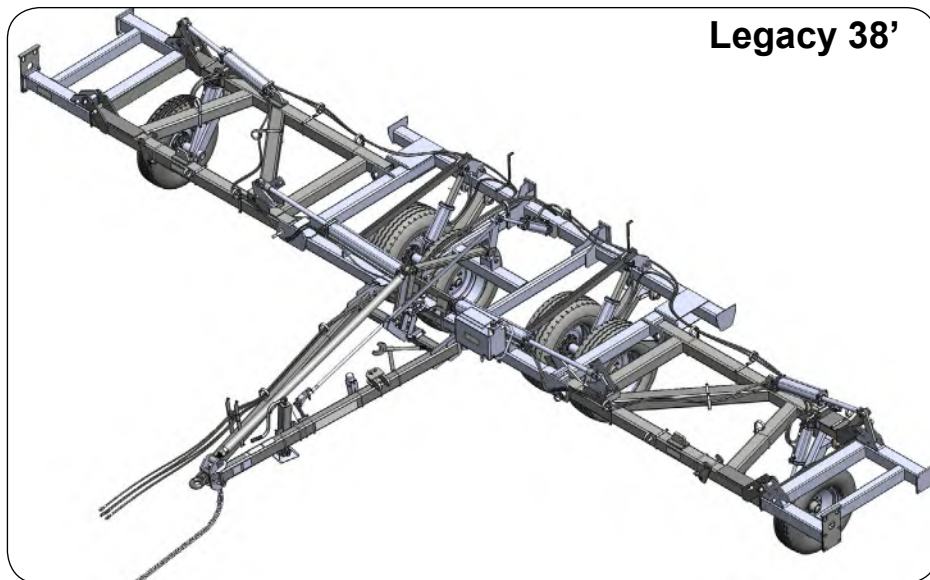

Legacy 47' and 52', Toolbars

Legacy 47'

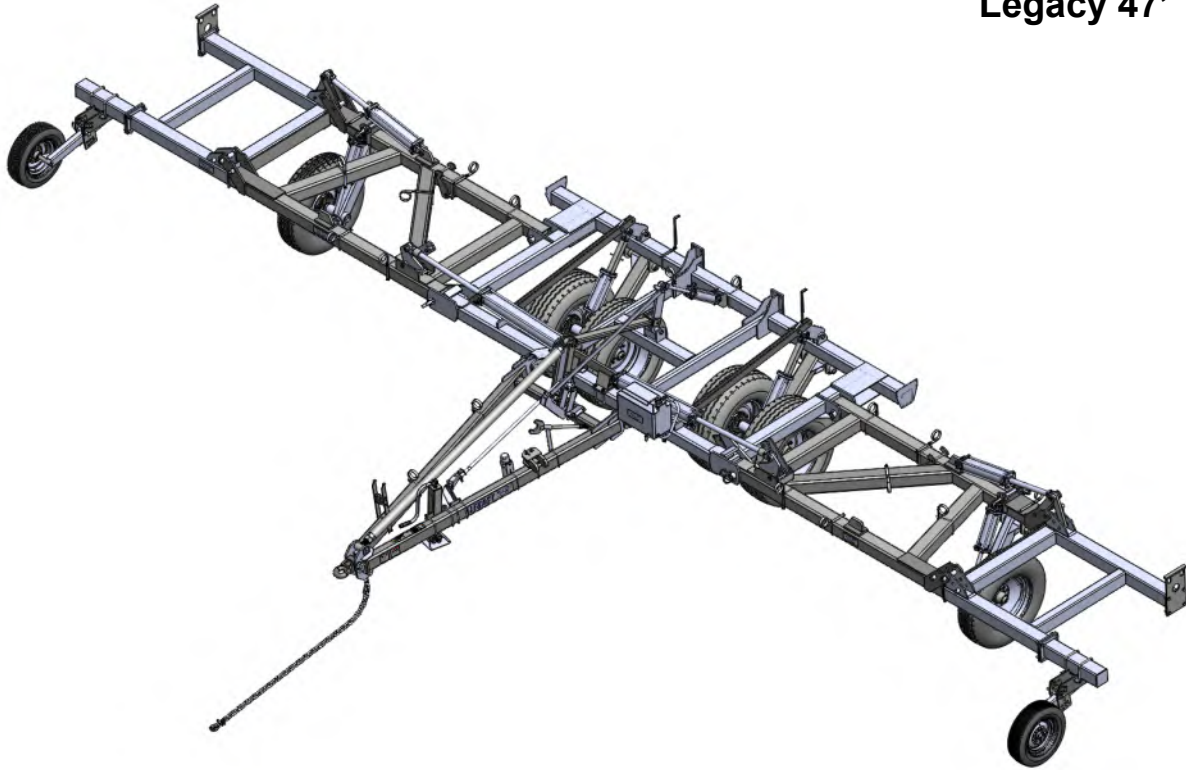

Legacy 52'



Overhead Layout - Legacy - 12 Row 30" Spacing

BLU-JET Legacy
12 Row 30" Spacing

SCS row units
SealPro II sealers

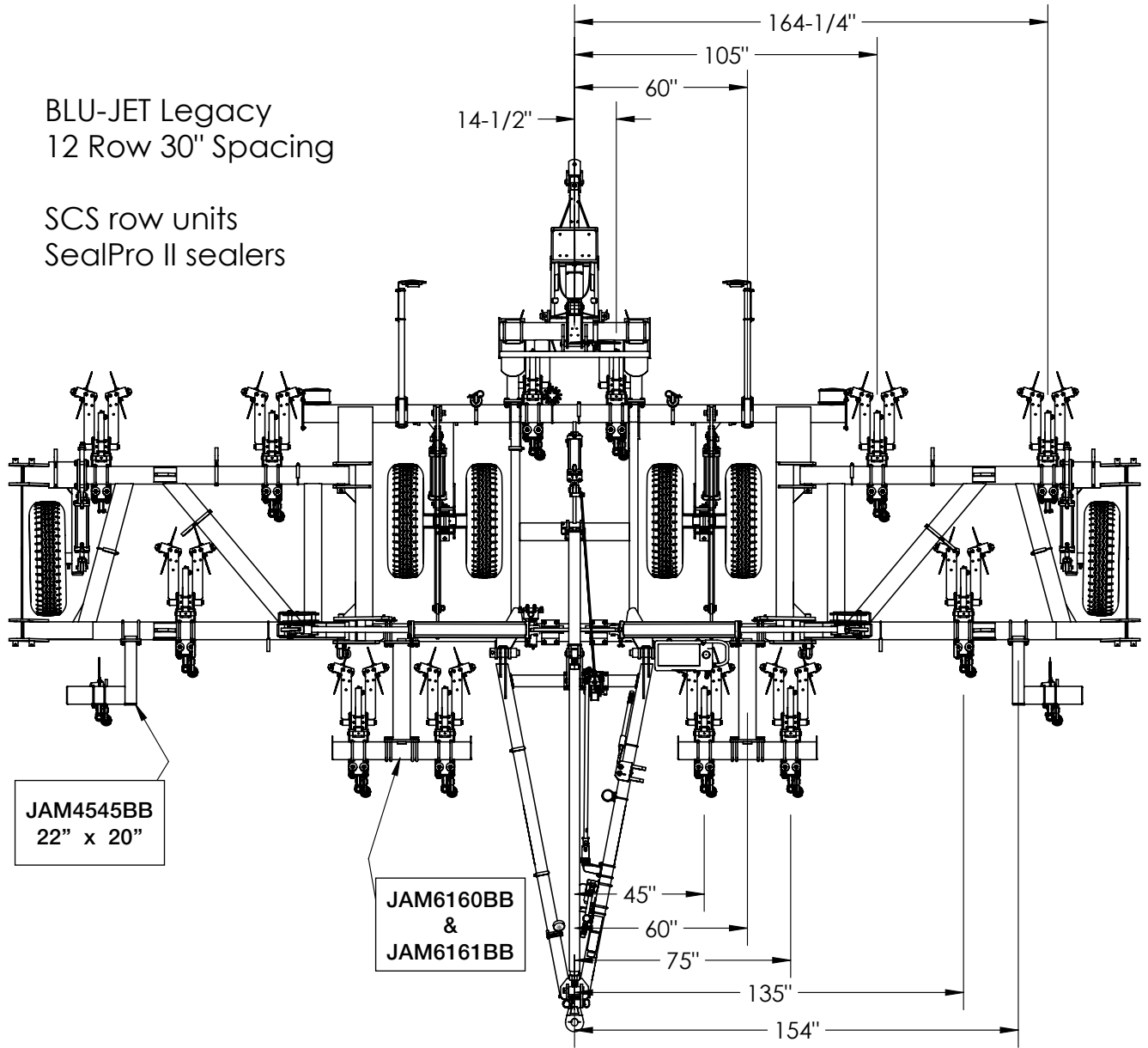

Overhead Layout - Legacy - 13 Row 30" Spacing

BLU-JET Legacy
13 Row 30" Spacing

SCS row units
SealPro II sealers

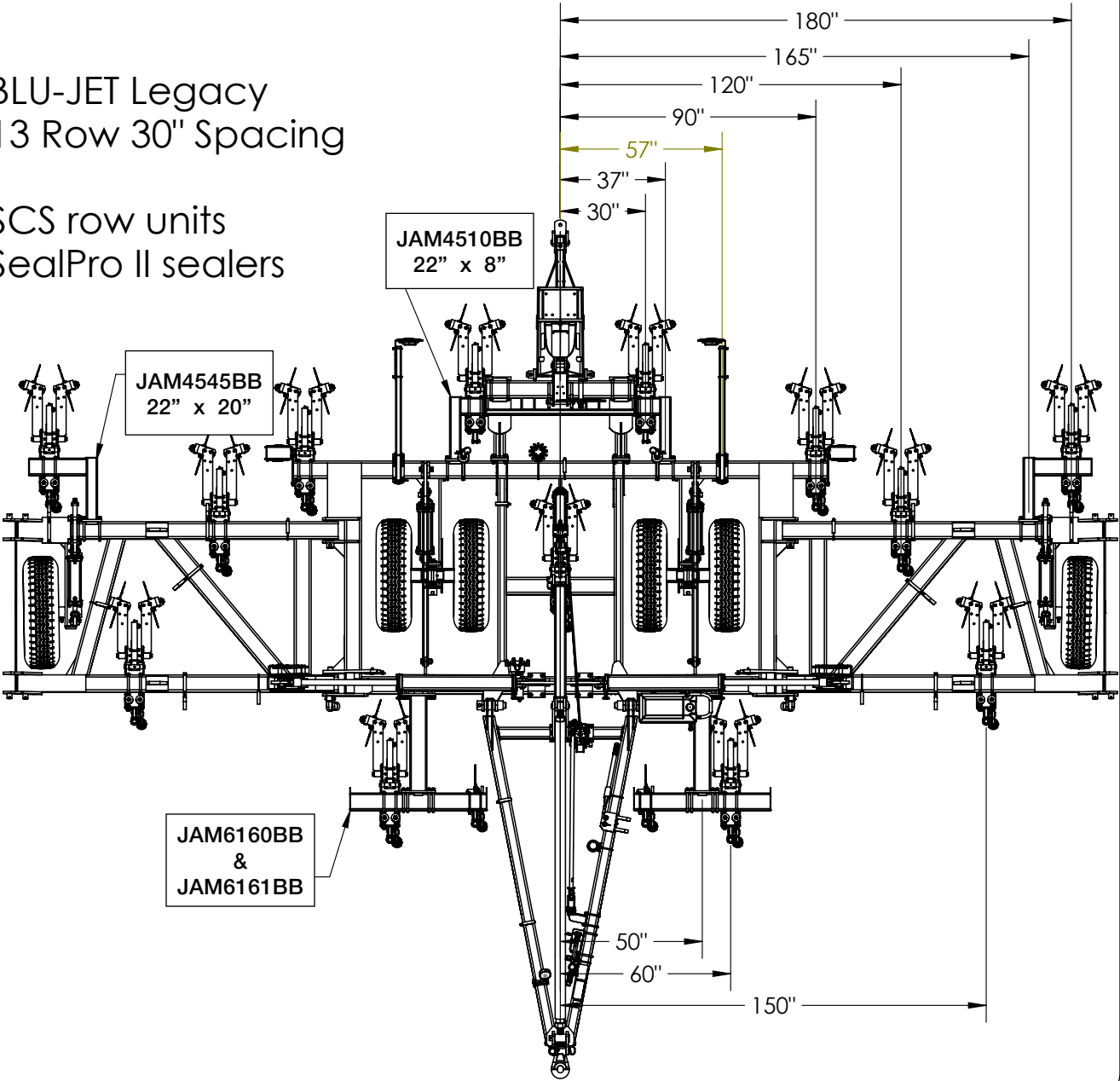

Overhead Layout - Legacy - 13 Row 30" Spacing

BLU-JET Legacy
13 Row 30" Spacing

MaxPac row units
SealPro II sealers

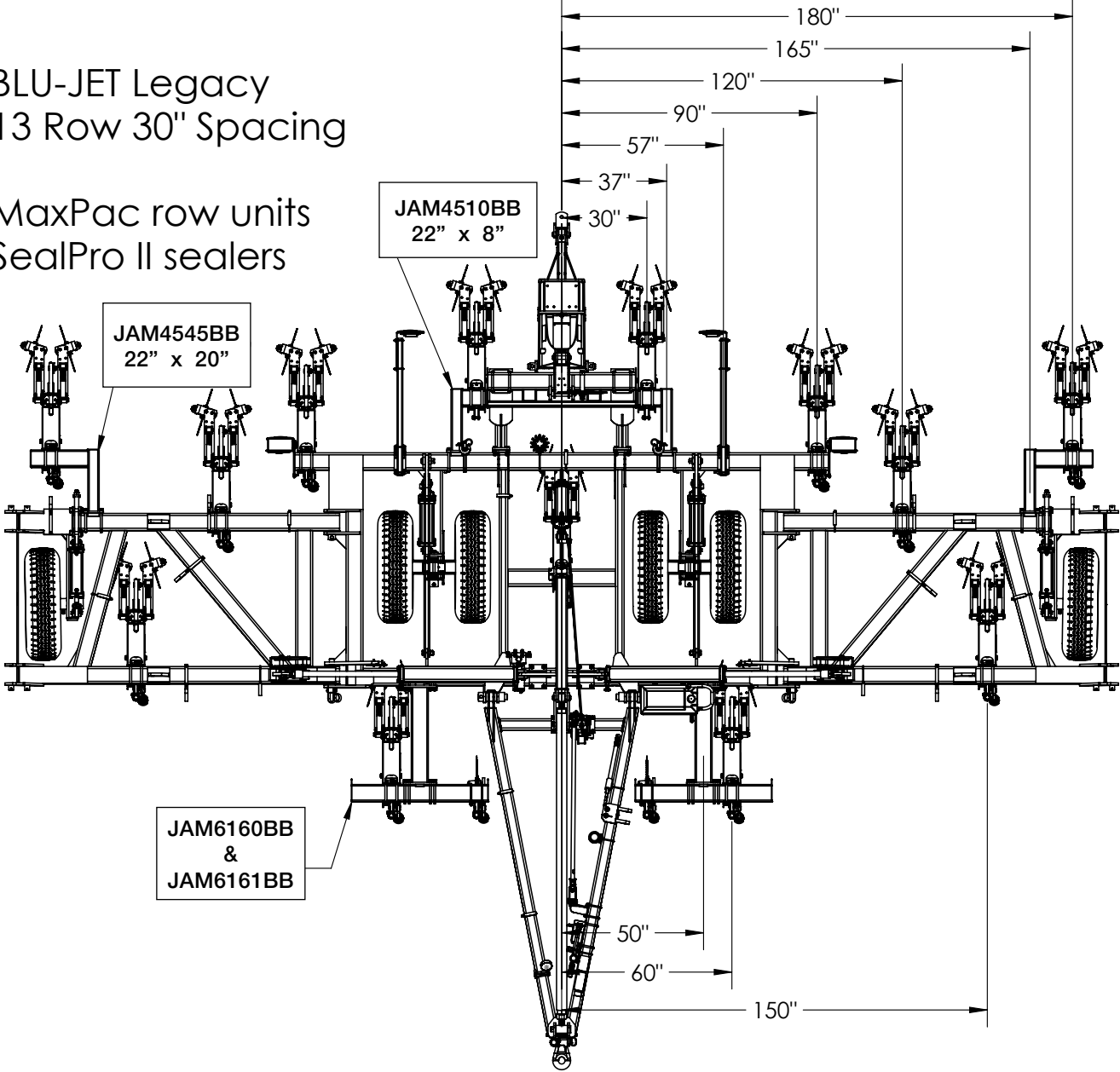

Overhead Layout - Legacy - 15 Row 30" Spacing

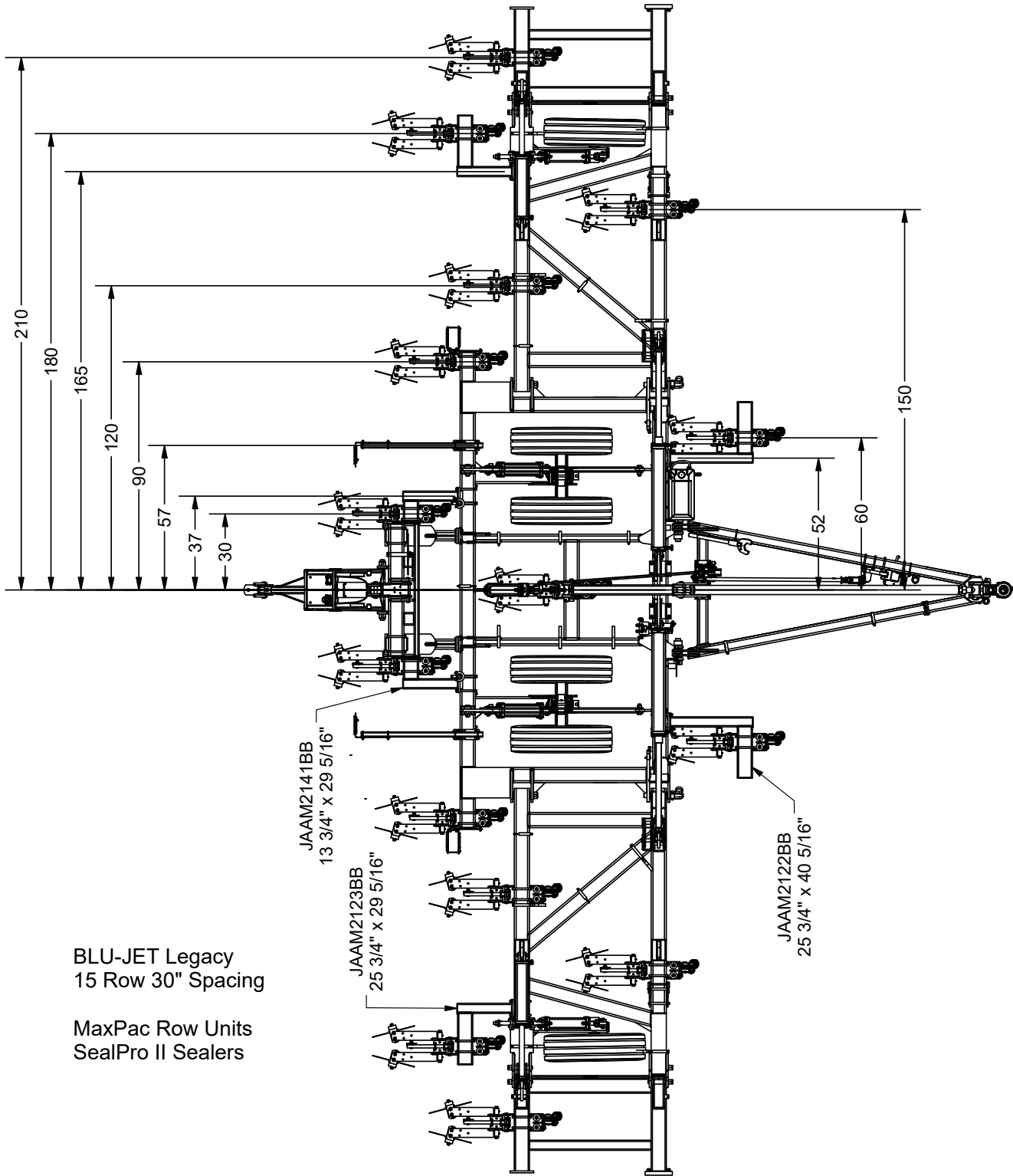

Overhead Layout - Legacy - 16 Row 30" Spacing

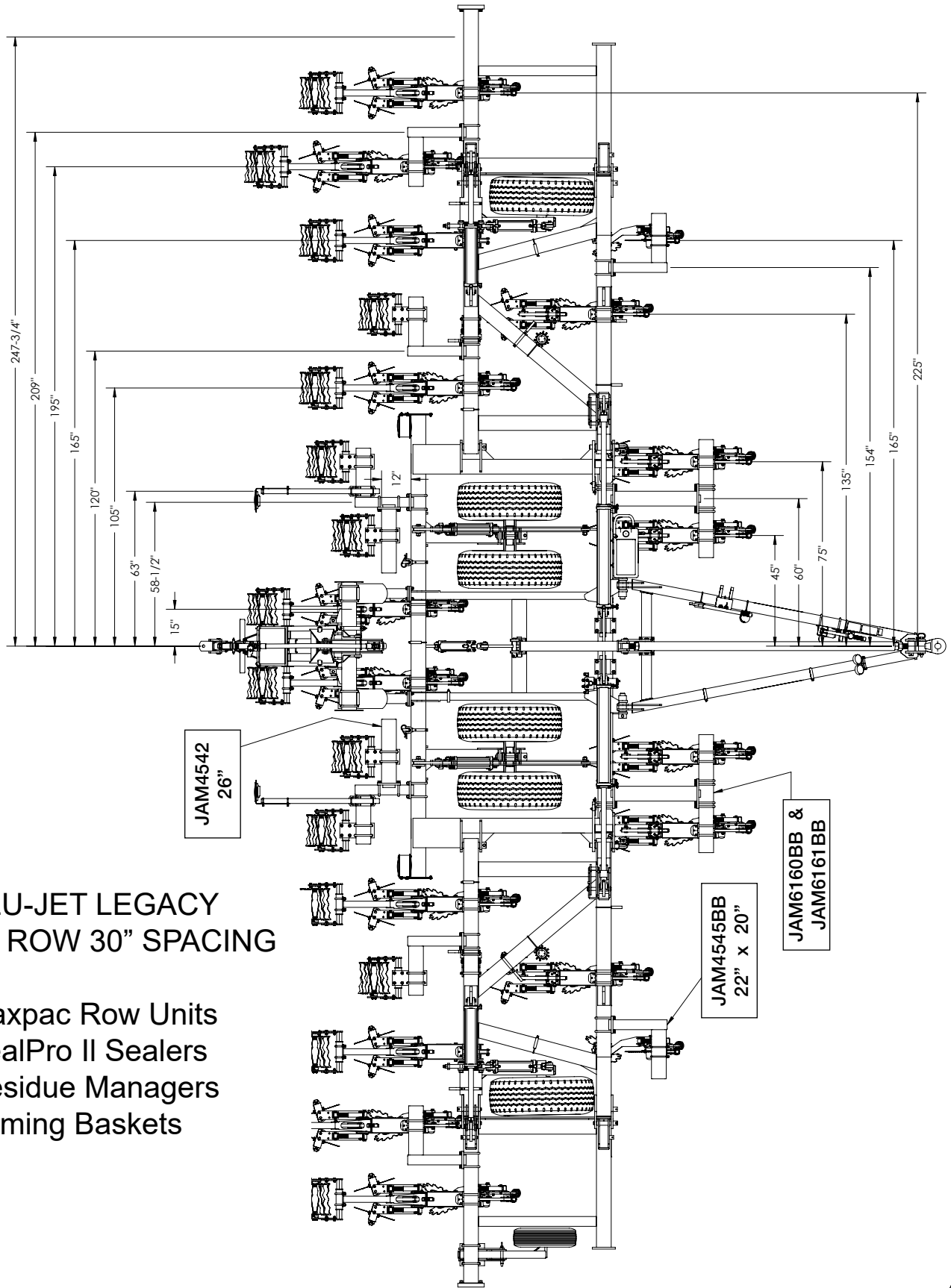

BLU-JET LEGACY
16 ROW 30" SPACING

Maxpac Row Units
SealPro II Sealers
Residue Managers
Firming Baskets

Overhead Layout - Legacy - 16 Row 30" Spacing

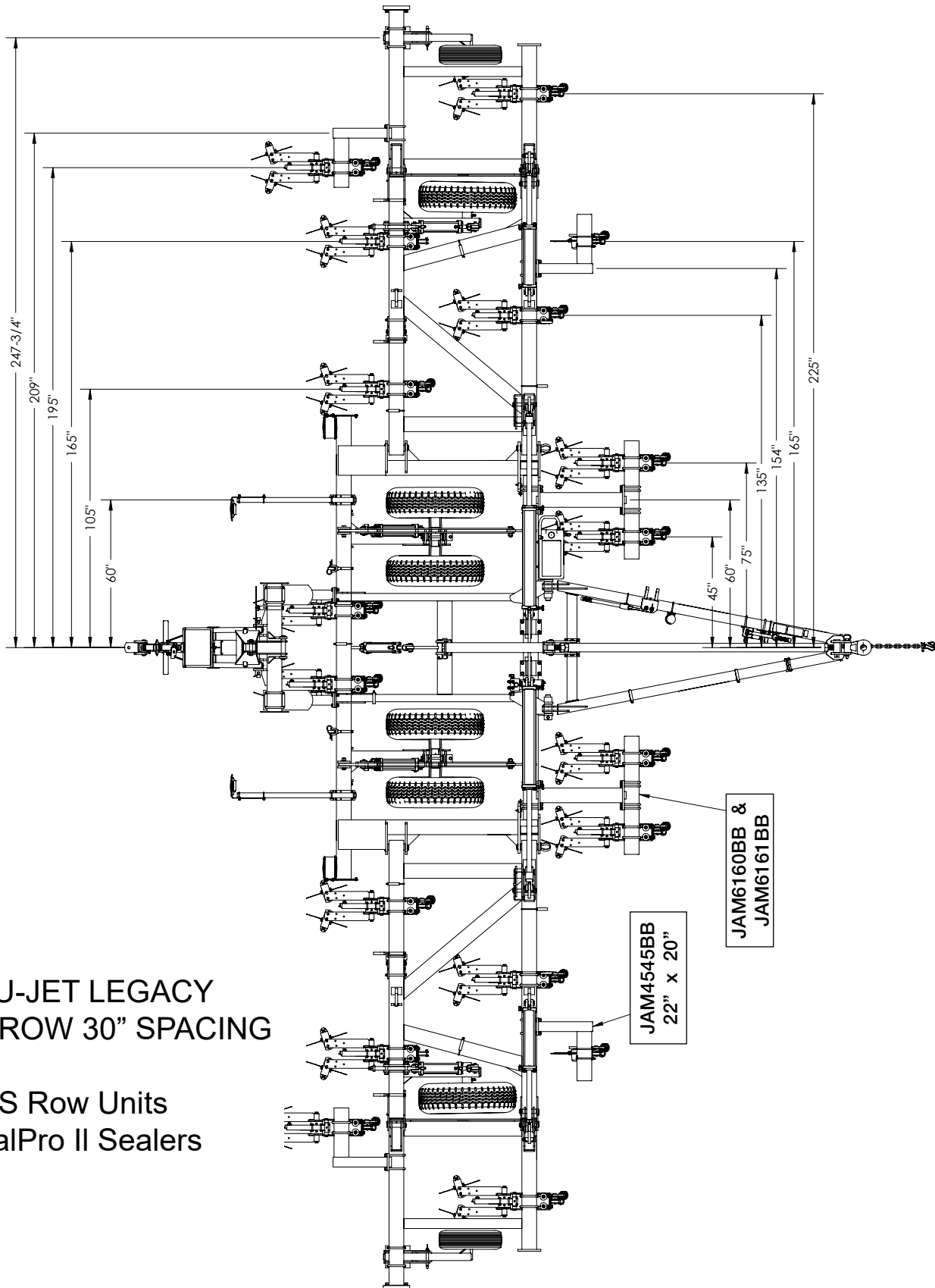

BLU-JET LEGACY
16 ROW 30" SPACING

SCS Row Units
SealPro II Sealers

Overhead Layout - Legacy - 17 Row 30" Spacing

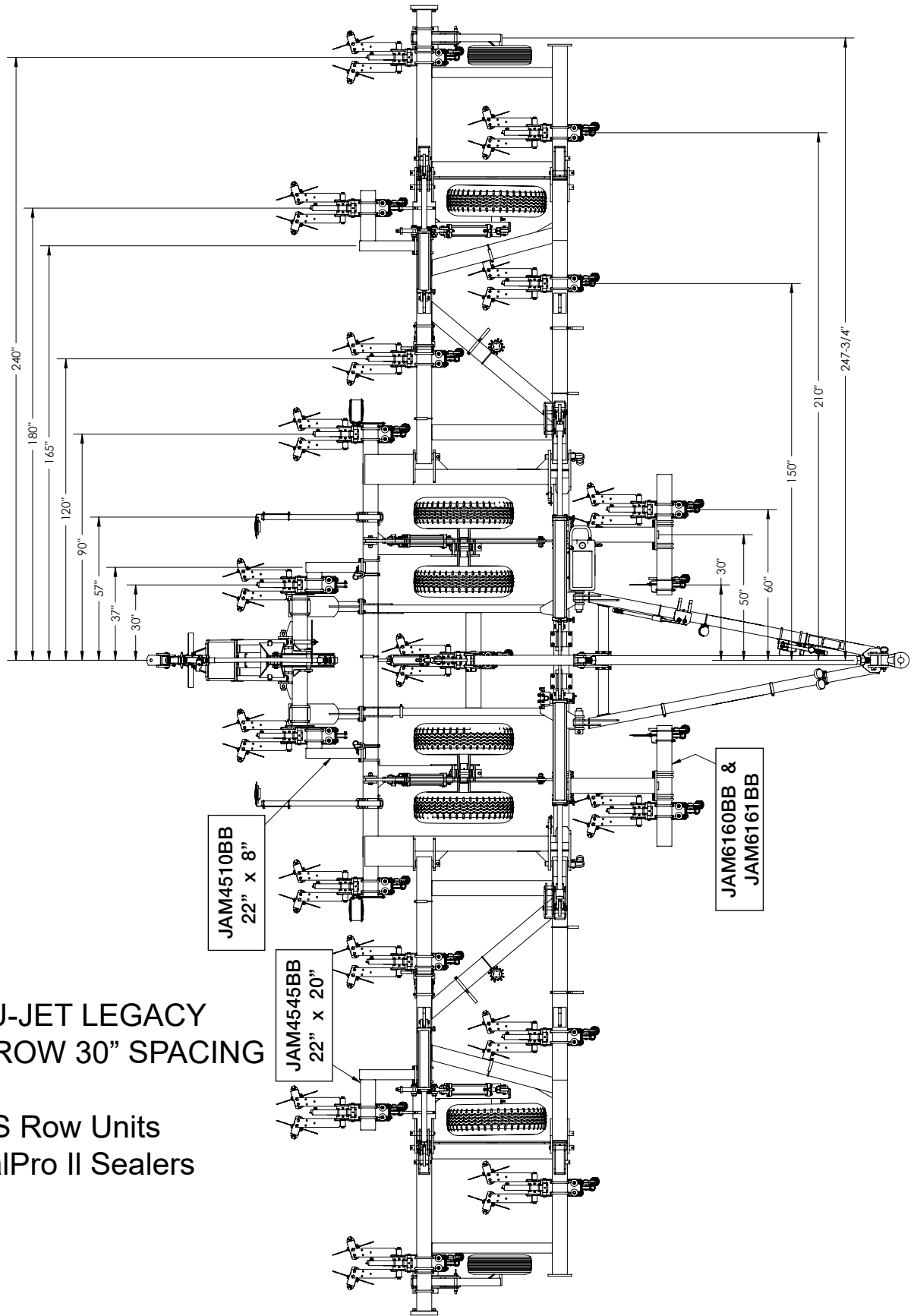

JAM4510BB
22" x 8"

JAM4545BB
22" x 20"

JAM6160BB &
JAM6161BB

BLU-JET LEGACY
17 ROW 30" SPACING

SCS Row Units
SealPro II Sealers

Overhead Layout - Legacy - 18 Row 20" Spacing

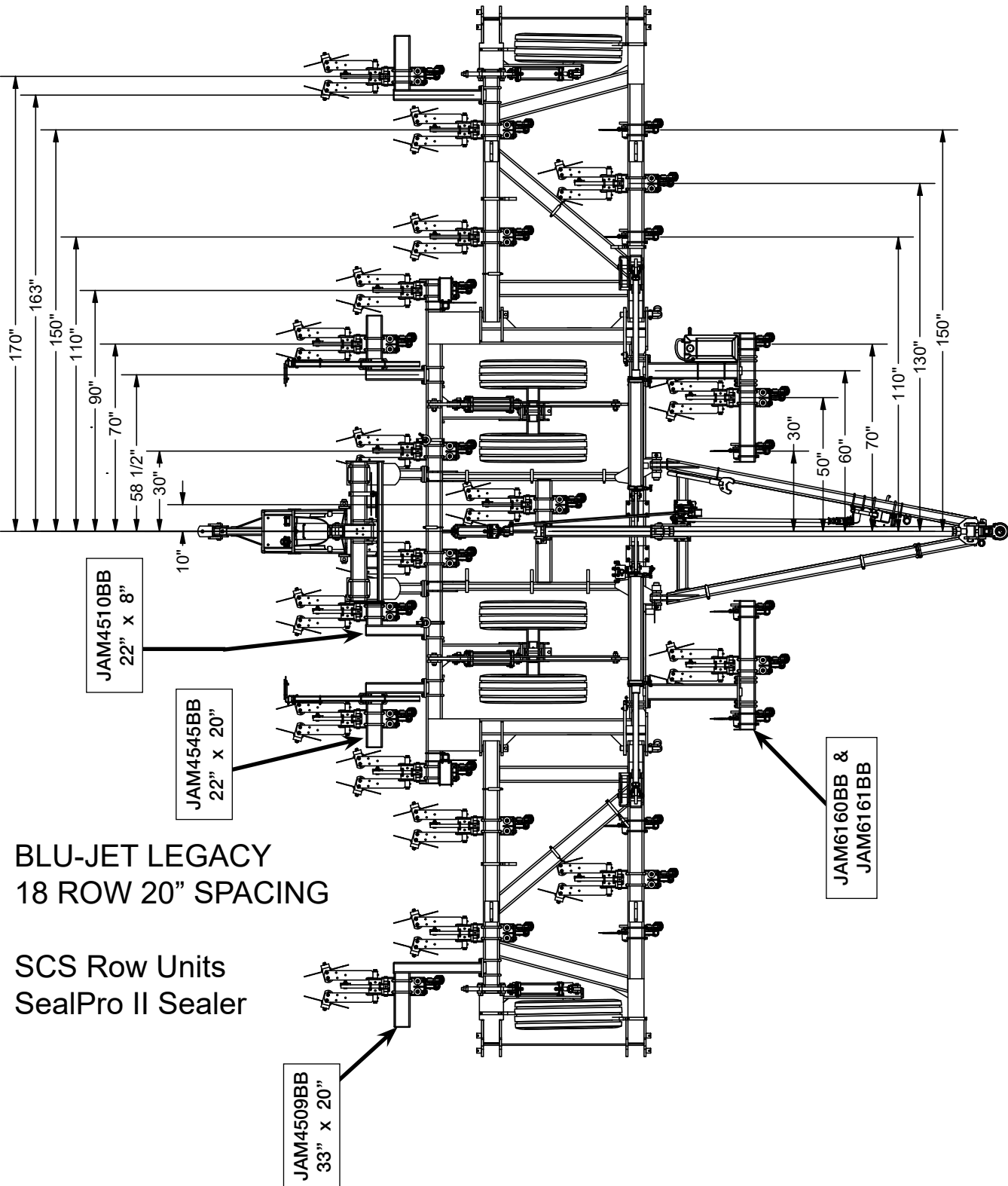

Overhead Layout - Legacy - 18 Row 30" Spacing

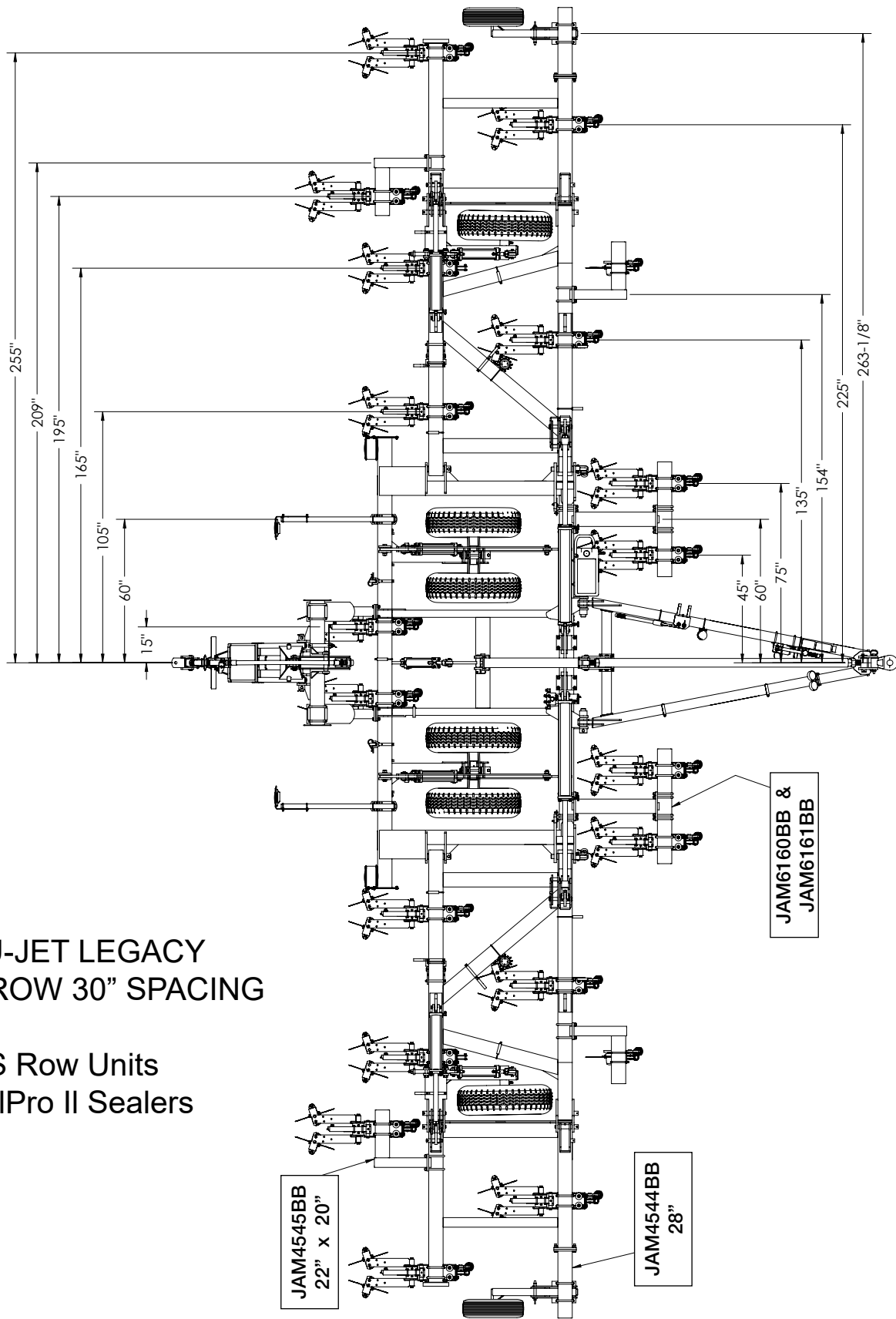

BLU-JET LEGACY
18 ROW 30" SPACING

SCS Row Units
SealPro II Sealers

JAM4545BB
22" x 20"

JAM4544BB
28"

JAM6160BB &
JAM6161BB

Overhead Layout - Legacy - 18 Row 30" Spacing

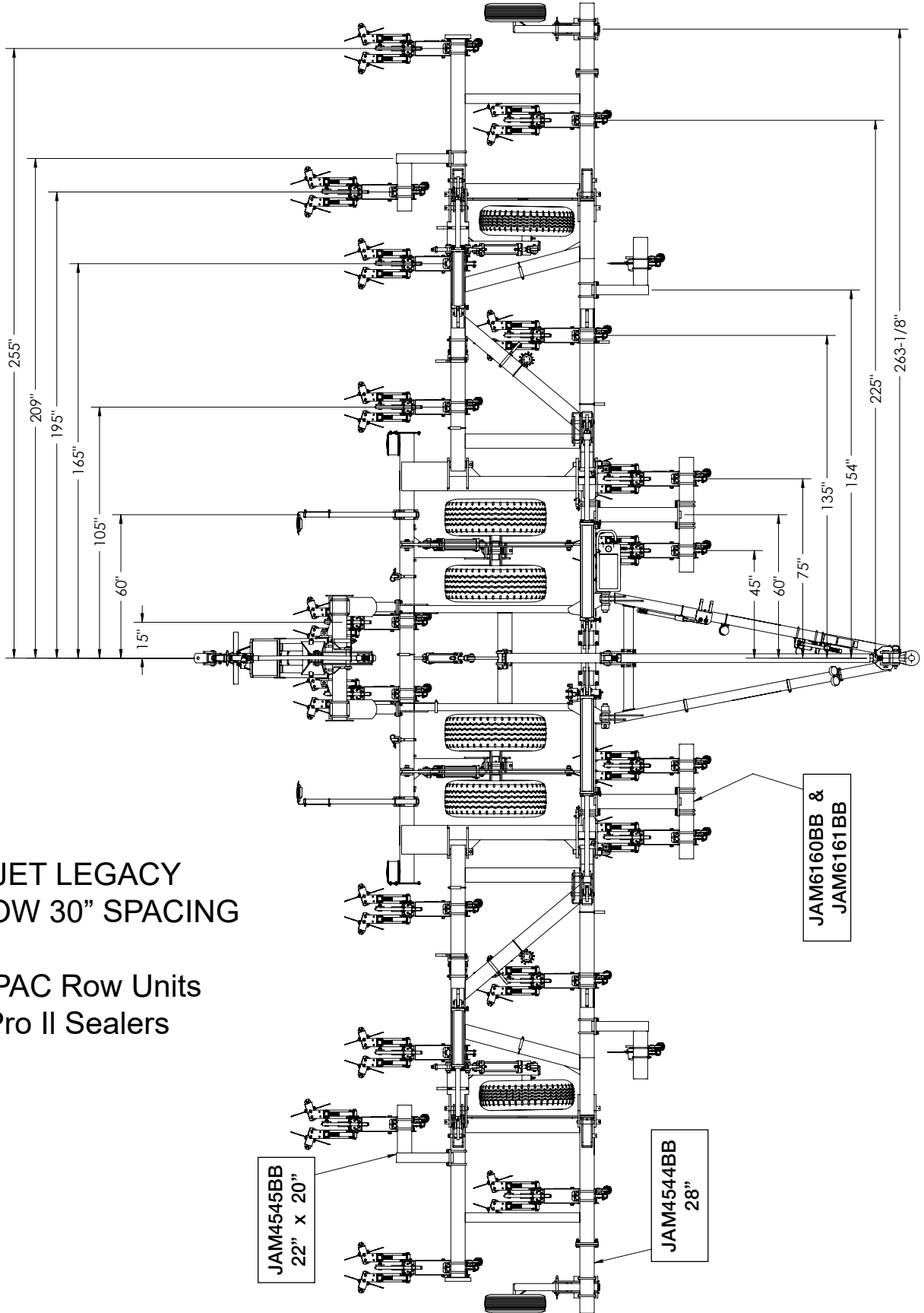

BLU-JET LEGACY
18 ROW 30" SPACING

MACPAC Row Units
SealPro II Sealers

Overhead Layout - Legacy - 18 Row 30" Spacing

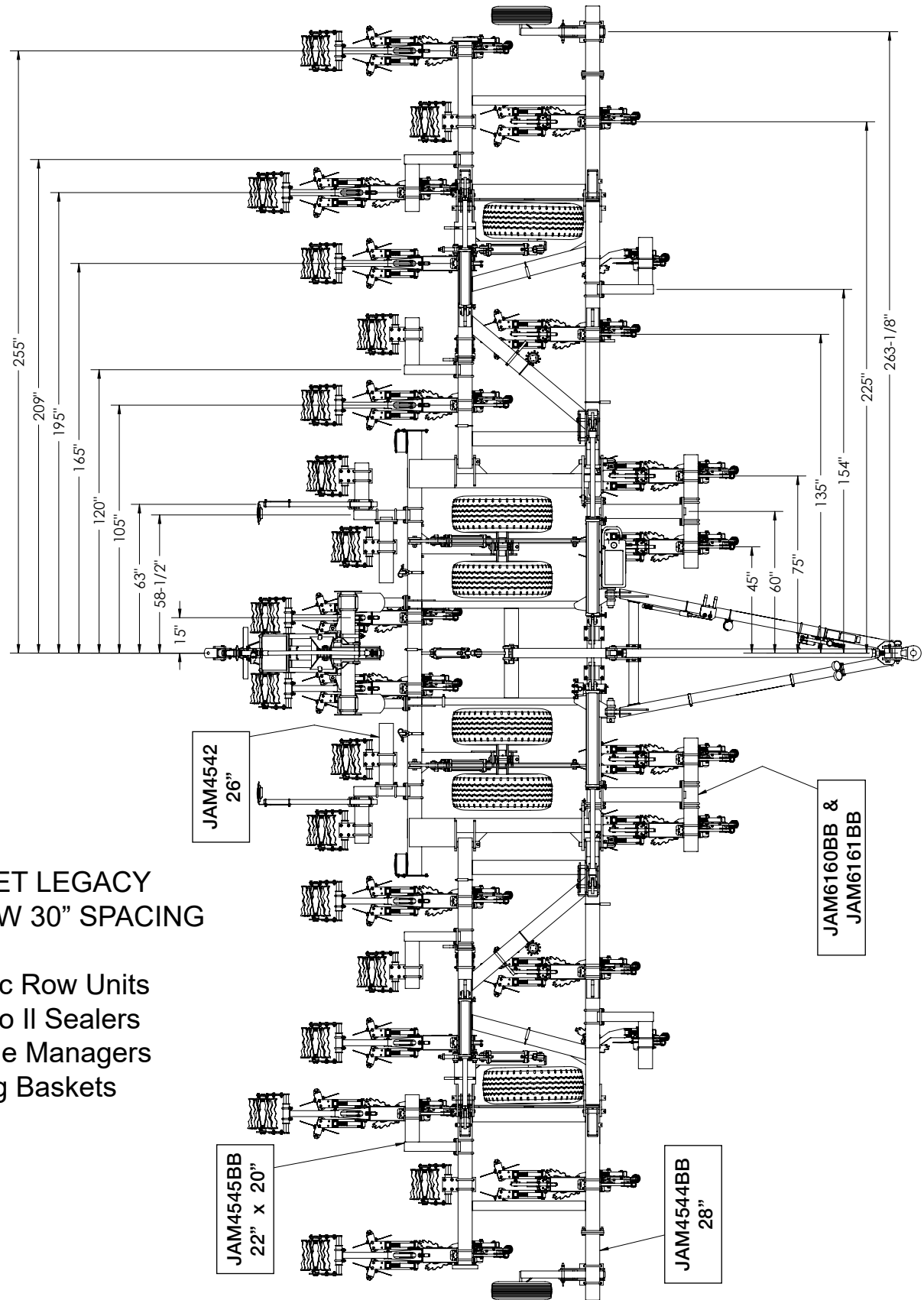

BLU-JET LEGACY
18 ROW 30" SPACING

Maxpac Row Units
SealPro II Sealers
Residue Managers
Firming Baskets

JAM4542
26"

JAM6160BB &
JAM6161BB

JAM4545BB
22" x 20"

JAM4544BB
28"

Overhead Layout - Legacy - 19 Row 30" Spacing

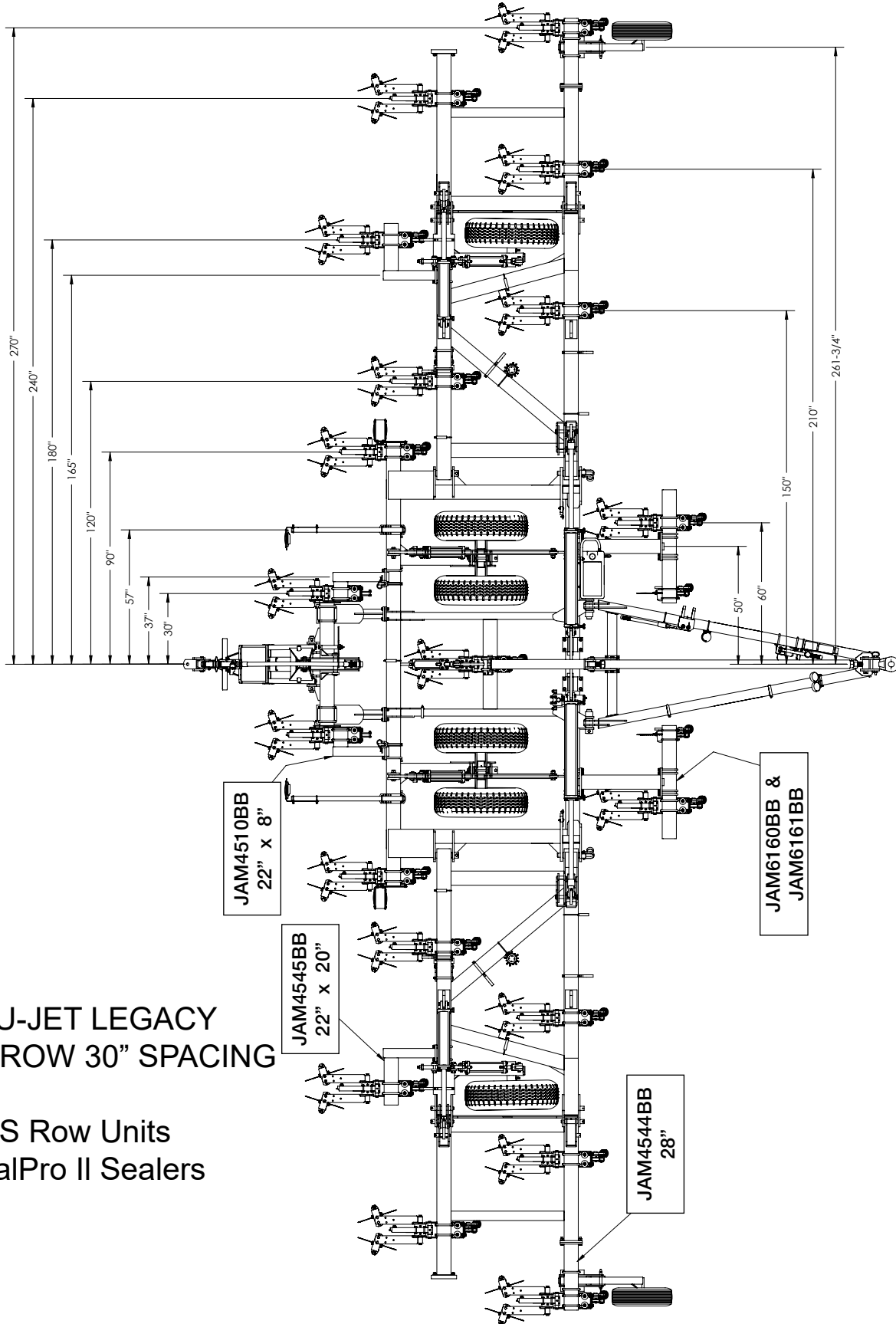

BLU-JET LEGACY
19 ROW 30" SPACING

SCS Row Units
SealPro II Sealers

Overhead Layout - Legacy - 21 Row 30" Spacing

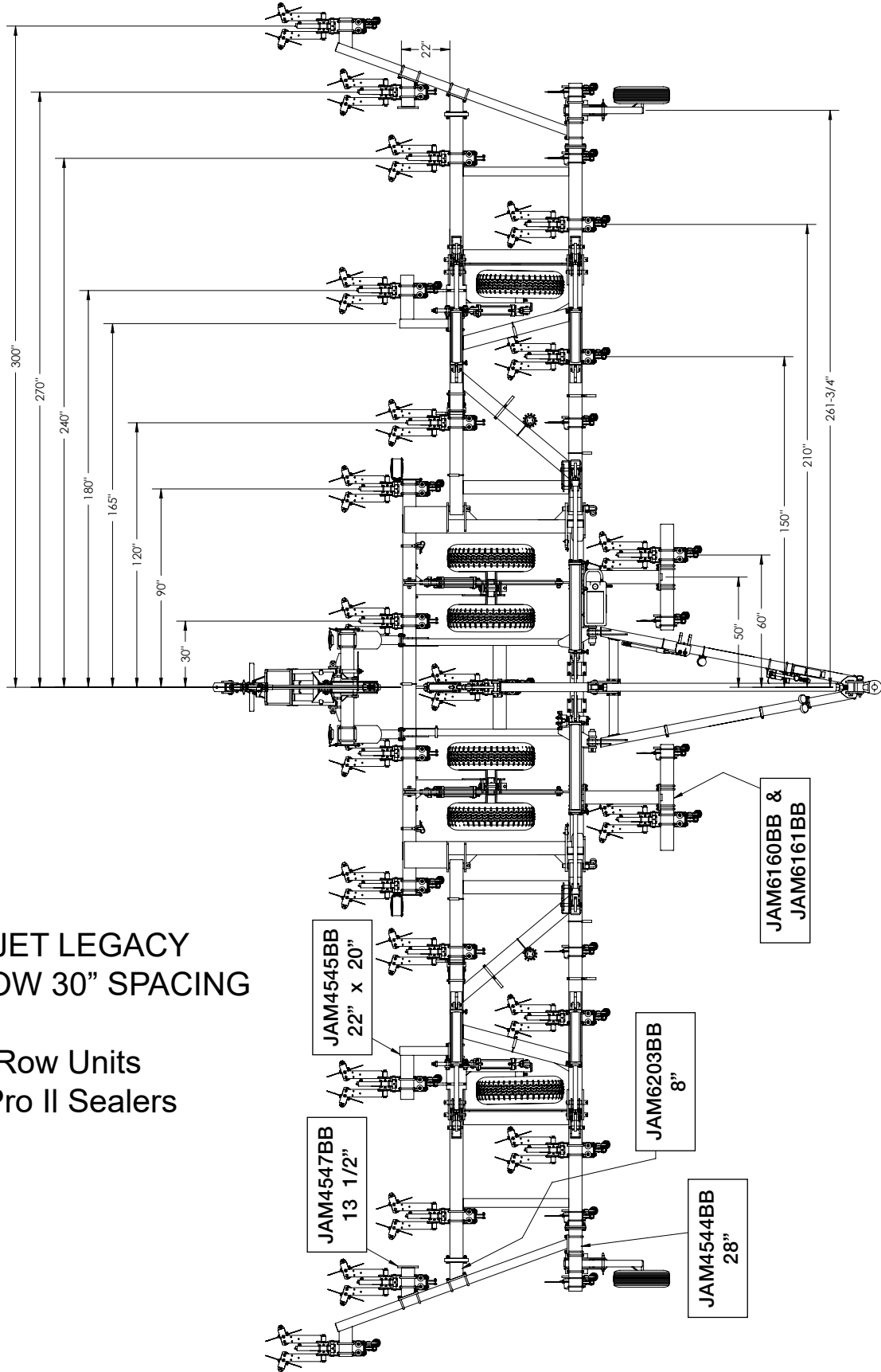

BLU-JET LEGACY
21 ROW 30" SPACING

SCS Row Units
SealPro II Sealers

JAM4545BB
22" x 20"

JAM4547BB
13 1/2"

JAM6203BB
8"

JAM4544BB
28"

JAM6160BB &
JAM6161BB

Overhead Layout - Legacy - 24 Row 20" Spacing

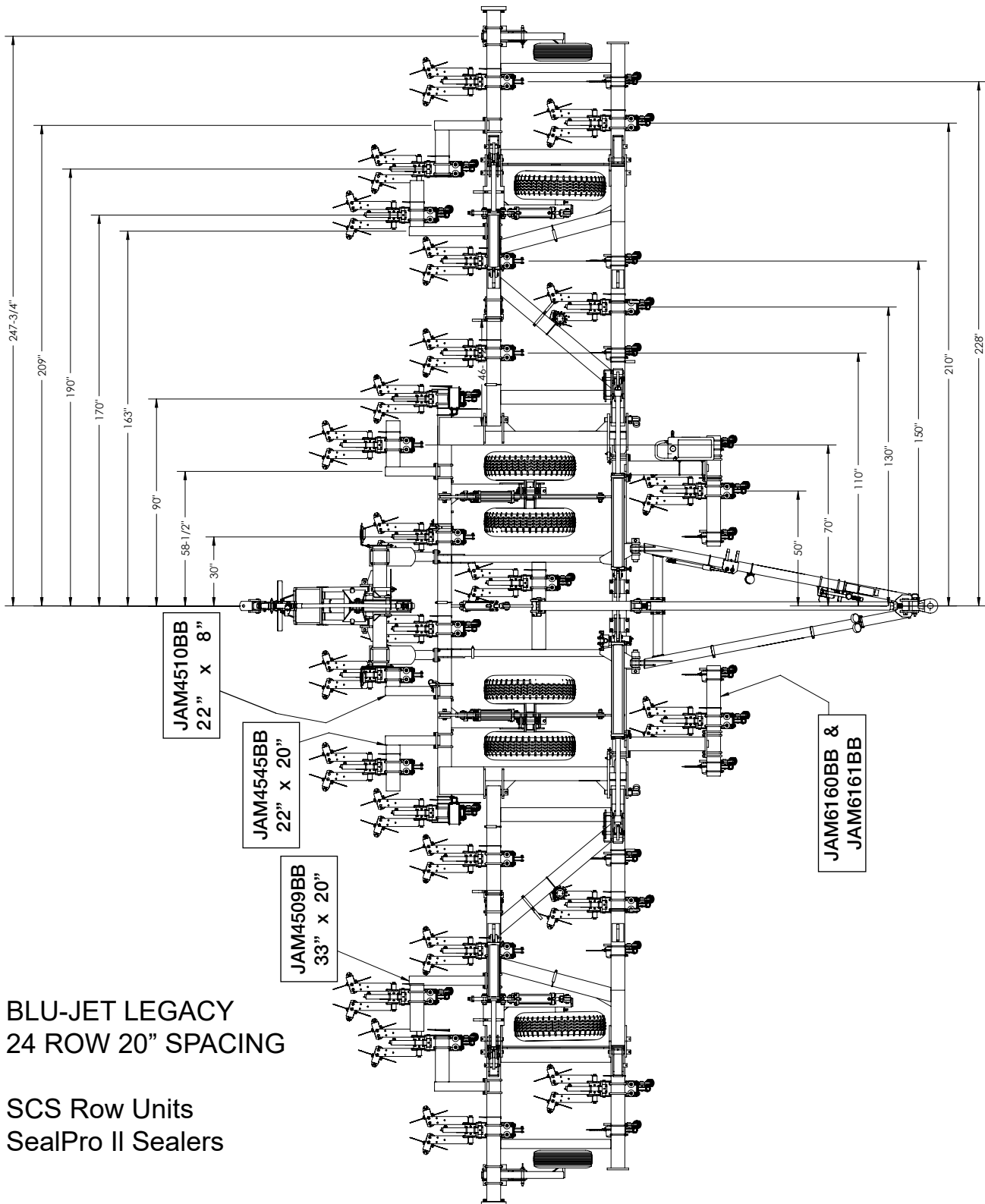

Overhead Layout - Legacy Side Dresser - 13 Row 30" Spacing

BLU-JET Legacy SD
13 Row 30" Spacing

SCS row units
SealPro II sealers

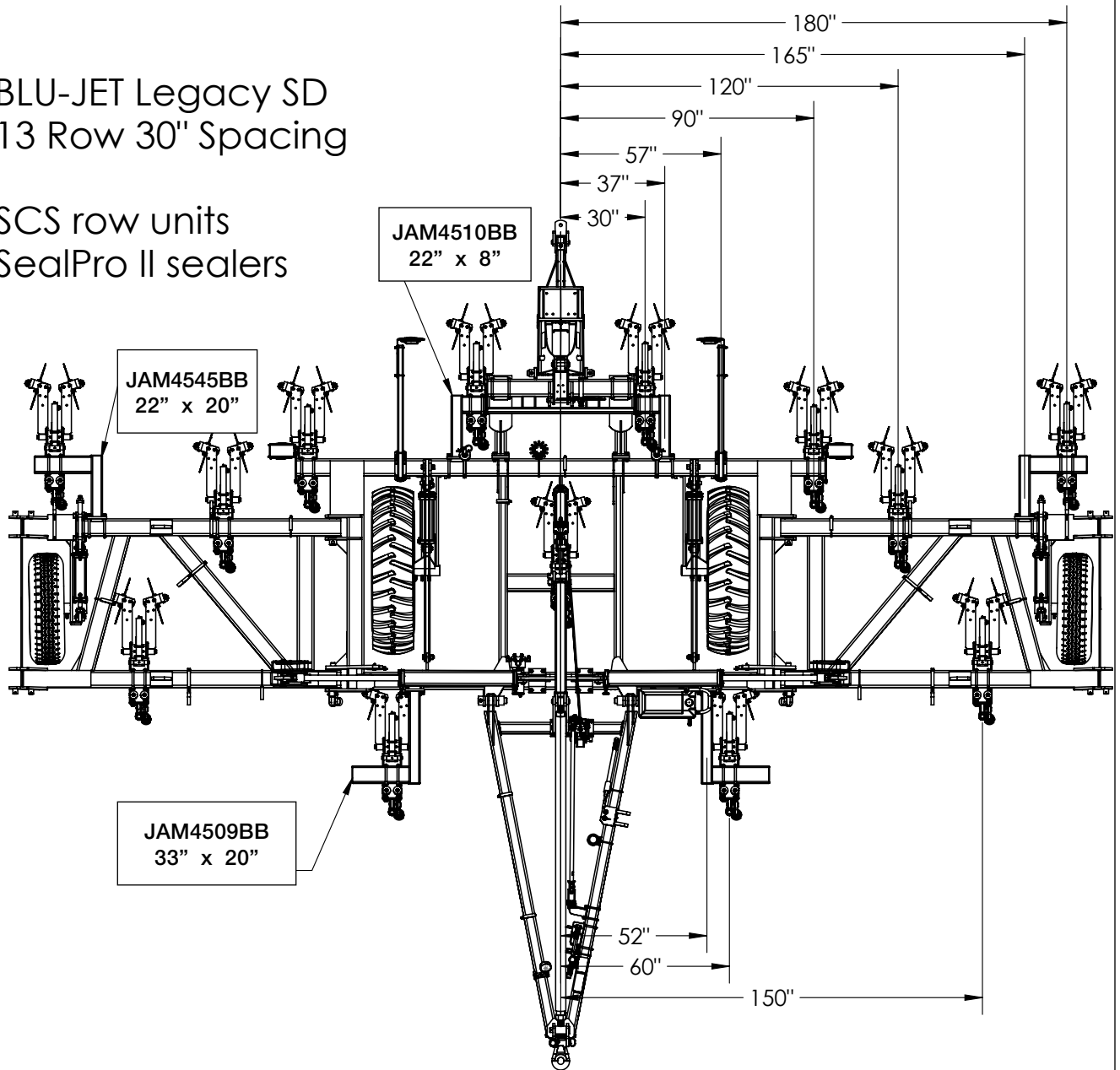

Overhead Layout - Legacy Side Dresser - 13 Row 30" Spacing

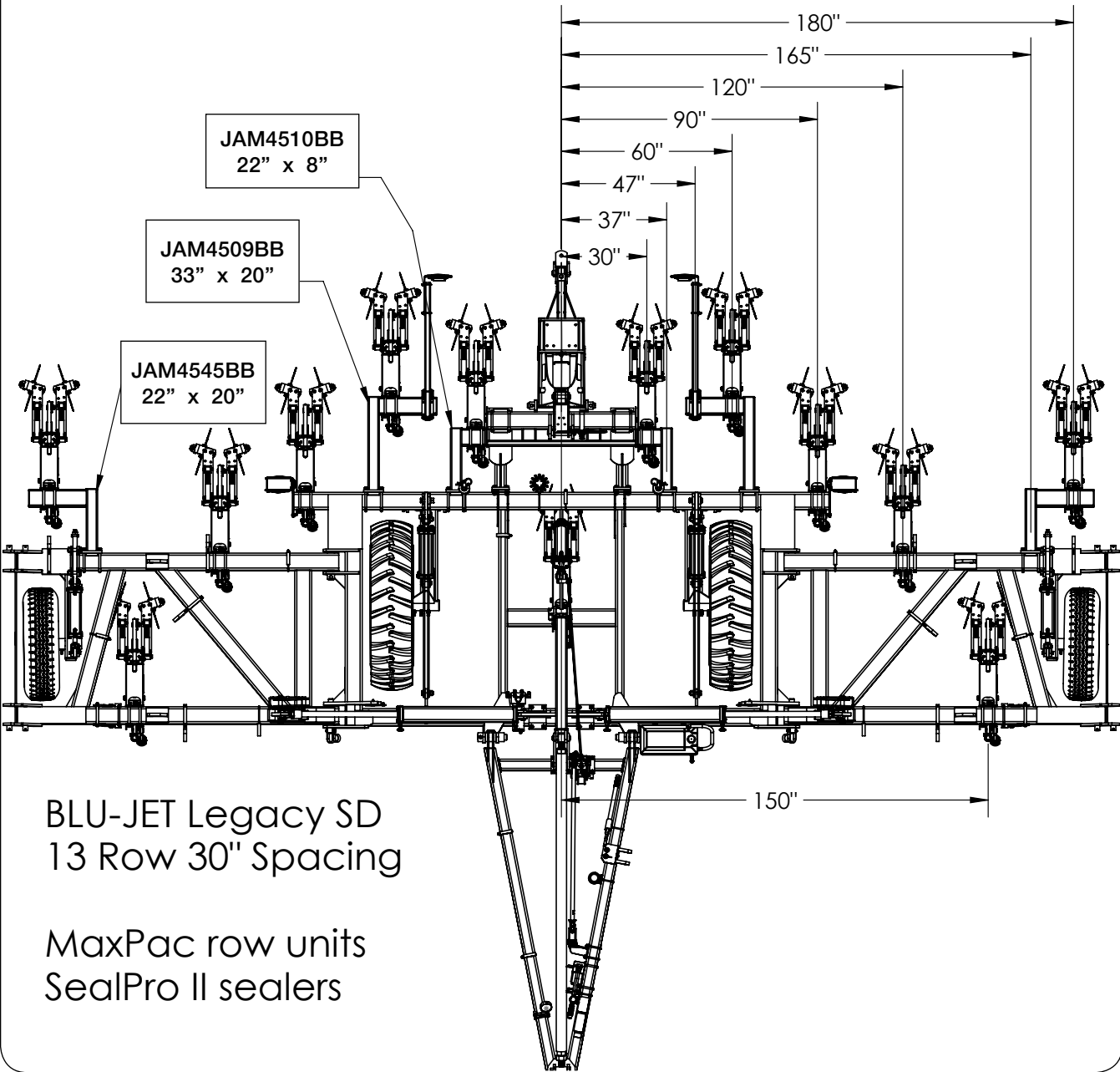

Overhead Layout - Legacy Side Dresser - 17 Row 30" Spacing

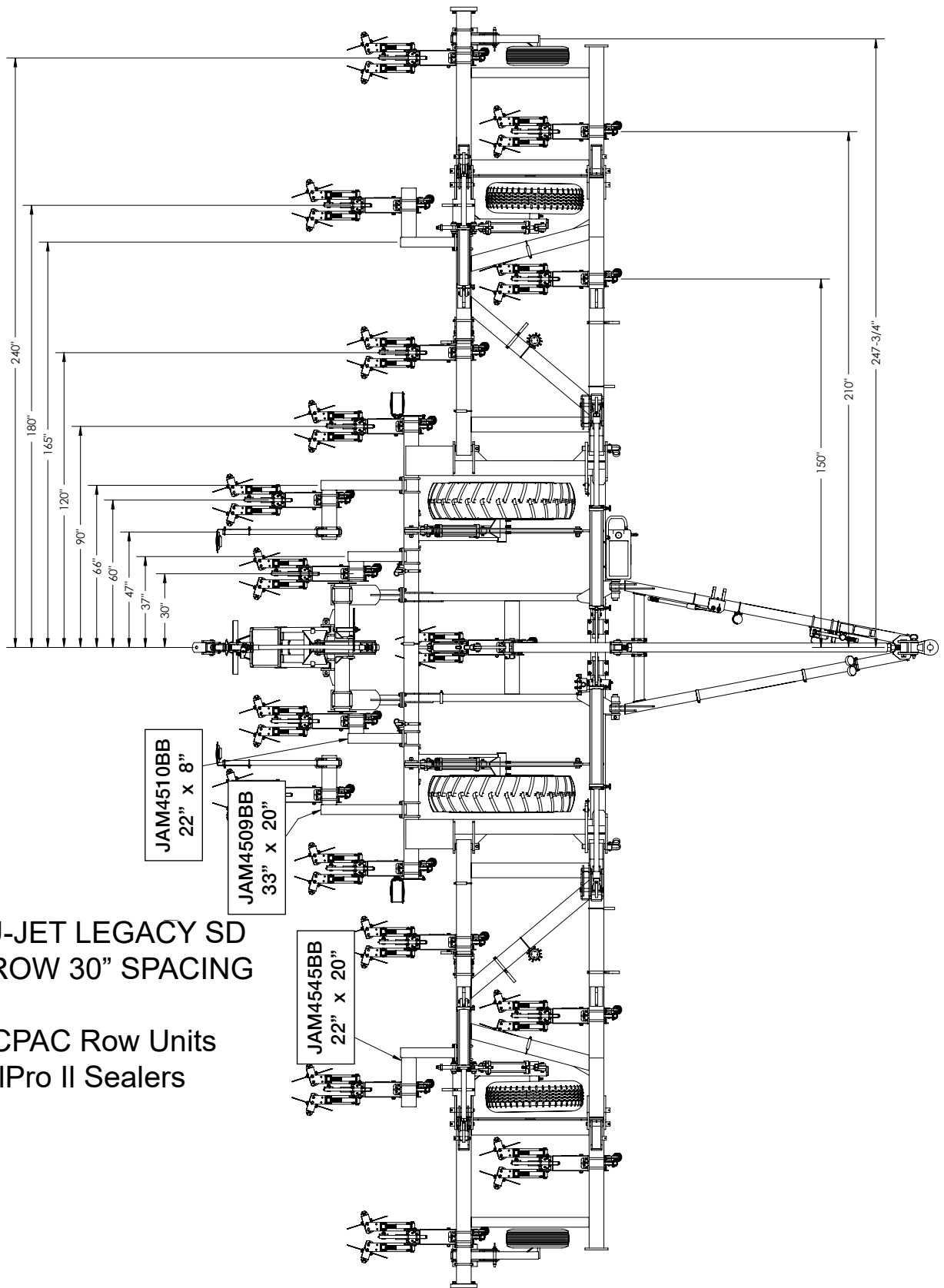

BLU-JET LEGACY SD
17 ROW 30" SPACING

MACPAC Row Units
SealPro II Sealers

Overhead Layout - Legacy Side Dresser - 17 Row 30" Spacing

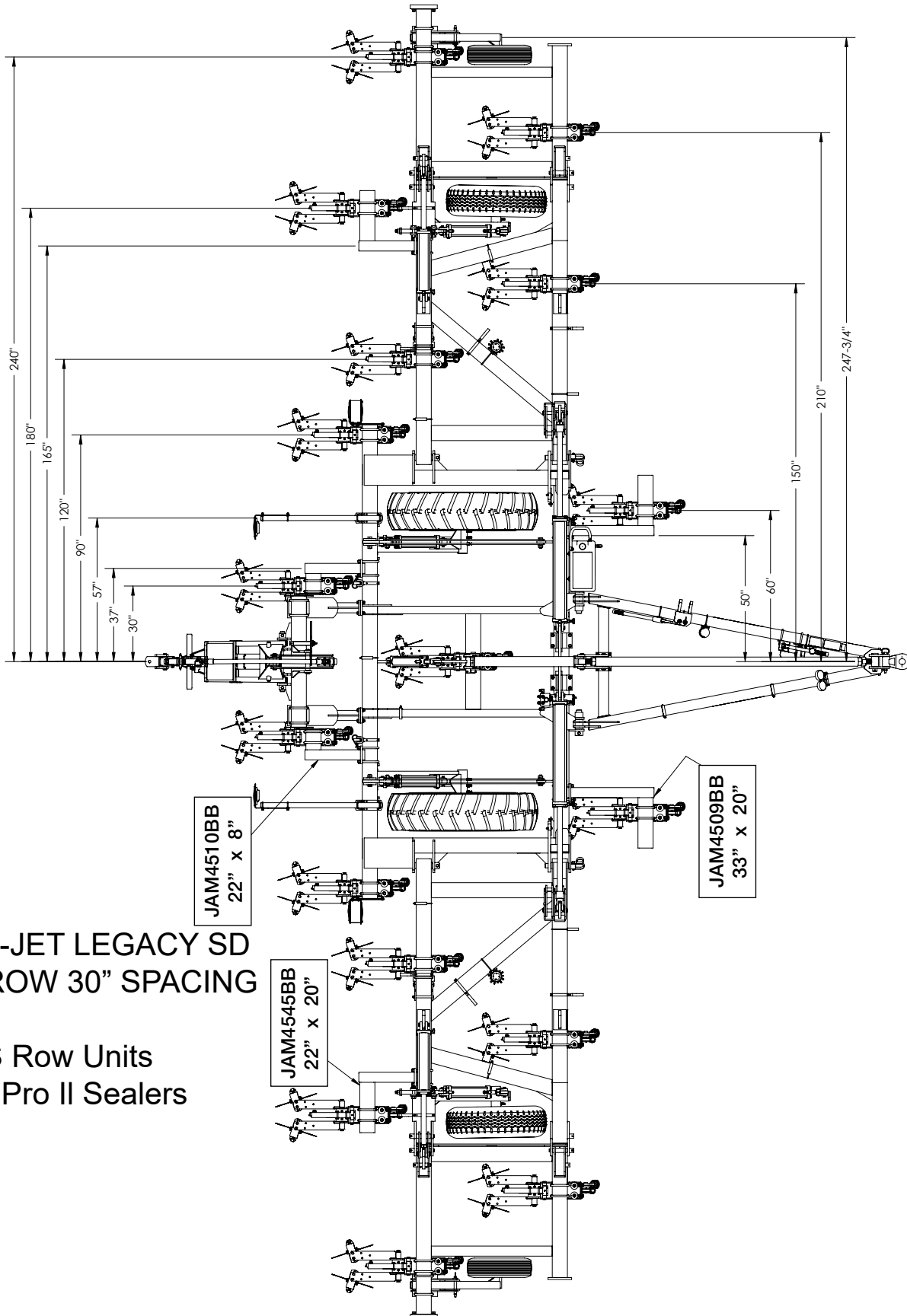

BLU-JET LEGACY SD
17 ROW 30" SPACING

SCS Row Units
SealPro II Sealers

Overhead Layout - Legacy Side Dresser - 19 Row 30" Spacing

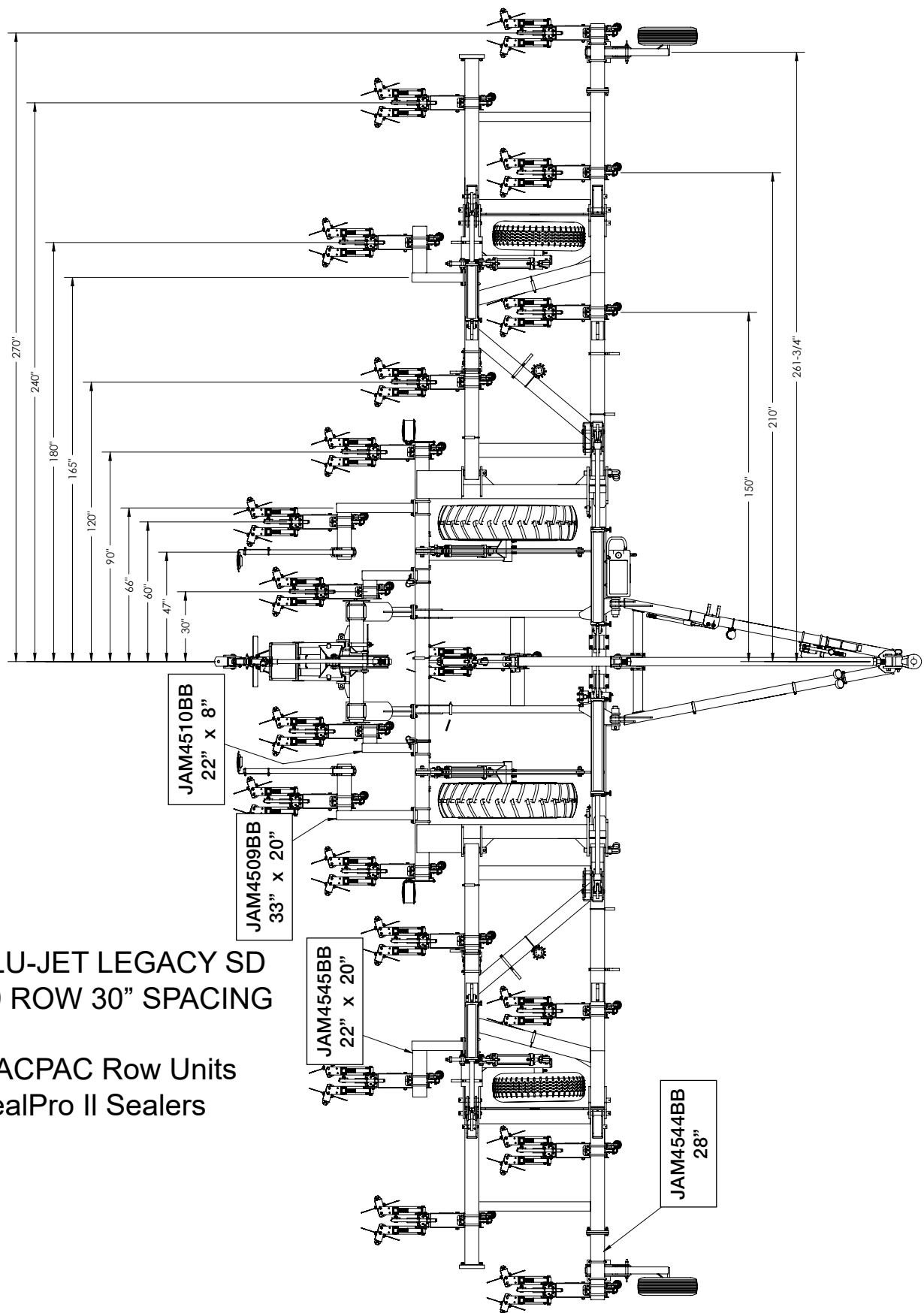

BLU-JET LEGACY SD
19 ROW 30" SPACING

MACPAC Row Units
SealPro II Sealers

Overhead Layout - Legacy Side Dresser - 19 Row 30" Spacing

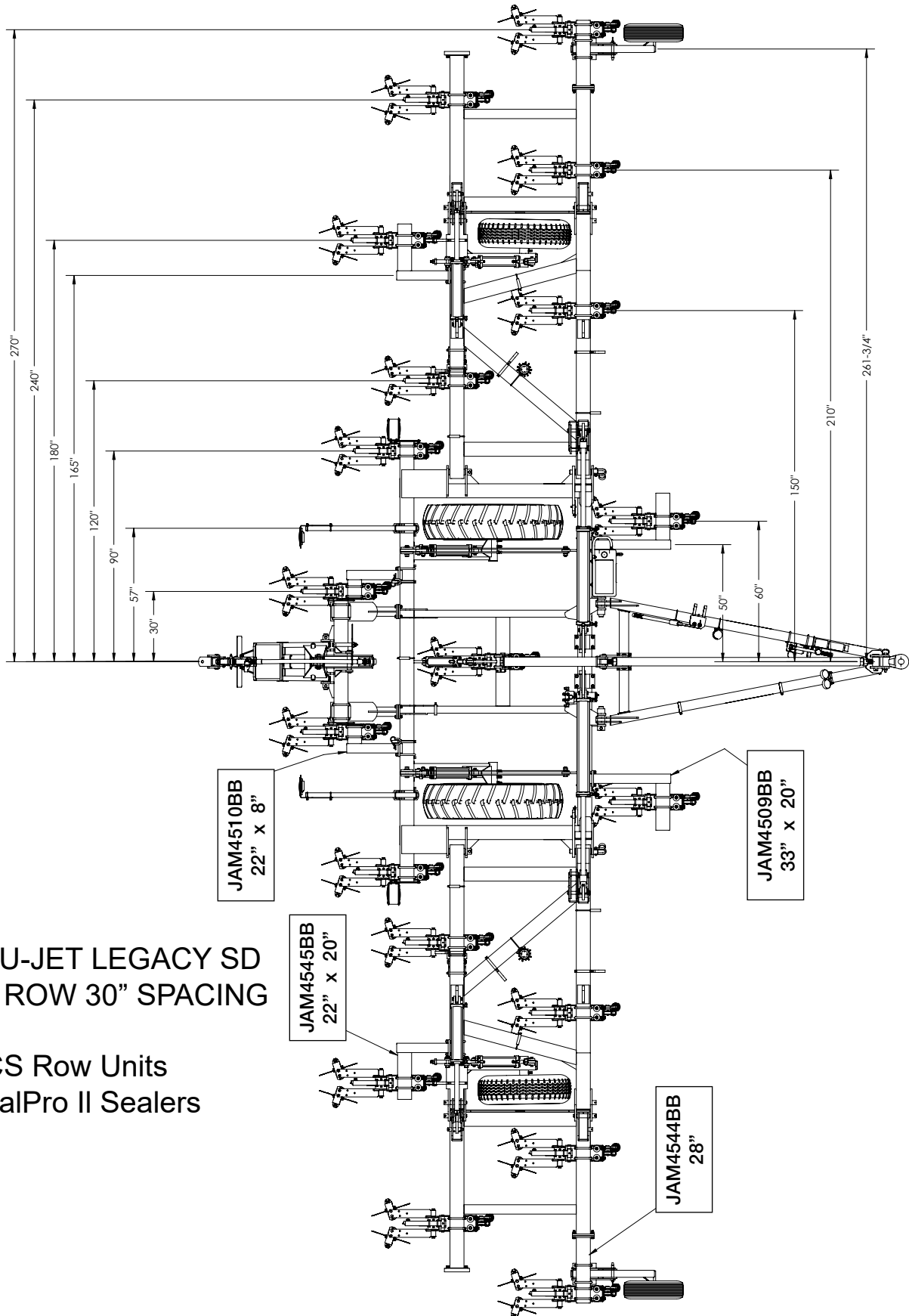

BLU-JET LEGACY SD
19 ROW 30" SPACING

SCS Row Units
SealPro II Sealers

Raven RCM Guide

RCM Set-Up

Whenever the tractor is turned off or the ECU for the anhydrous applicator loses power, the following steps will have to be performed in order for the RCM to function properly right away.

NOTE: Before programming the RCM, ensure the RCM monitor is connected to the battery.

1. On the initial start-up screen, begin by entering the profile name for your anhydrous applicator.
2. Select “NH3 Tool” as the desired machine type from the drop down menu.
3. Enter the application width of your anhydrous applicator.

NOTE: Highest value for Application Width is 62.5 ft or 750 in.

4. Press the Next Page icon.
5. Default for ECU box is 1. Touch Number of Products box and enter 1.
6. Press the Next Page icon.

The 'Name Profile' screen displays the following fields and values:

- Profile Name: Um NH3
- Machine Type: NH3 Tool
- Application Width: 750 (in)
- Software Version Number: 1.4.0.8
- Hardware Serial Number: 1208

At the bottom, there is a 'RAVEN' label and a right-pointing arrow icon.

The 'Setup System' screen displays the following fields and values:

ECU S/N	ECU #	Number of Products
RCM-1208	1	1 ?

At the bottom, there is a 'RAVEN' label and a right-pointing arrow icon.

Raven RCM Guide (continued)

7. Under Application Type, select “NH3” or “NH3 HP+” depending on cooler type.

NOTE: “NH3 HP+” is only used with the Raven AccuFlow HP+ cooler equipped with a PWM boost pump.

8. Press the Next Page icon.



9. Enter the number of sections. If desired, select equal width sections.

10. Press the Next Page icon.

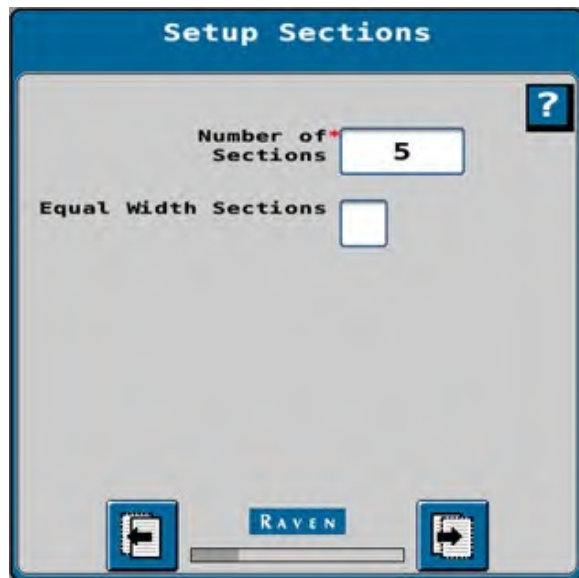

Raven RCM Guide (continued)

11. Verify or enter the widths of the individual sections.

NOTE: If section widths are unknown, simply count the number of rows plumbed into each section and multiply by the row width. Section 1 will start on the left hand side of the machine when facing the machine from the rear.

12. Press the Next Page icon.

Setup Section Width

Enter the width of the sections

1 (in)	150
2 (in)	150
3 (in)	150
4 (in)	150
5 (in)	150

Navigation: [Left Arrow] RAVEN [Right Arrow]

13. Ensure all the boxes are selected as "None".

14. Press the Next Page icon.

Setup Auxiliary Drivers

Auxiliary Driver 1	None	?
Auxiliary Driver 2	None	
Auxiliary Driver 3	None	
Auxiliary Driver 4	None	
Auxiliary Driver 5	None	
Auxiliary Driver 6	None	

Navigation: [Left Arrow] RAVEN [Right Arrow]

Raven RCM Guide (continued)

15. Review the information on the Section Summary screen.
16. If the information is correct, press the Next Page icon. To make adjustments to the configuration, press Back and adjust settings as needed.

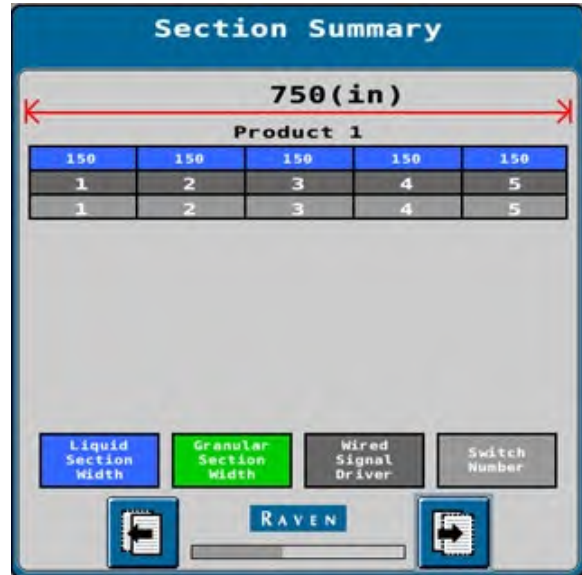

17. Ensure this box is "None".
18. Press the Next Page icon.



Raven RCM Guide (continued)

19. Select “0-250psi (1-5V)” for pressure sensor 1. If cooler is equipped with PWM Boost Pump, select “0-250psi (1-5V)” for pressure sensor 2 as well.

20. Press the Next Page icon.

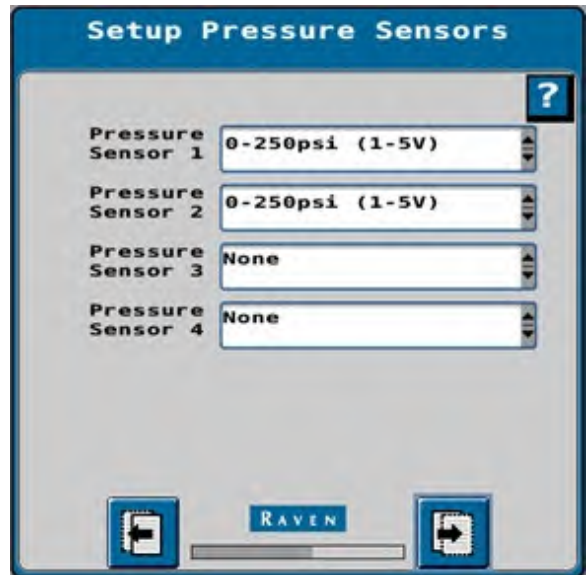

21. Setup desired pressure alarms for each of the pressure sensors.

22. Press the Next Page icon.

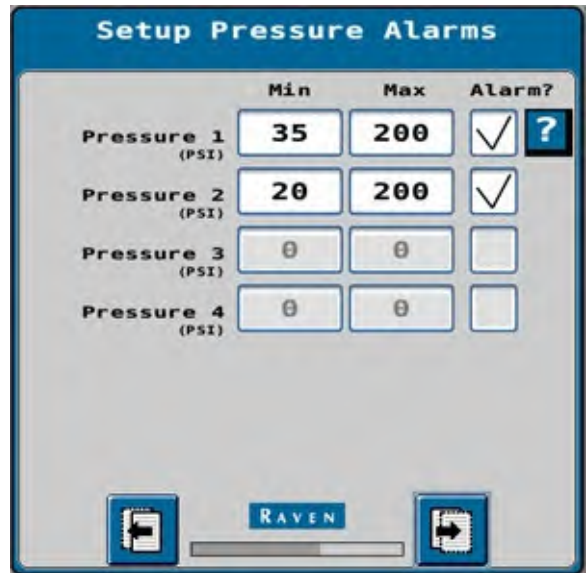

Raven RCM Guide (continued)

23. Select the control valve type, either “AccuFlow Dual Valve” or “AccuFlow Single Valve”. These correspond to the number of control valves at the cooler.

24. Enter the desired Valve Response Rate, Control Deadband, and Control Effort. If “AccuFlow Dual Valve” setup is selected, also enter desired Valve Delay and Valve Advance.

NOTE: The pictured values are generic starting numbers. You can fine tune these values to best fit your application. The white question mark outlines what happens when adjusting each value.

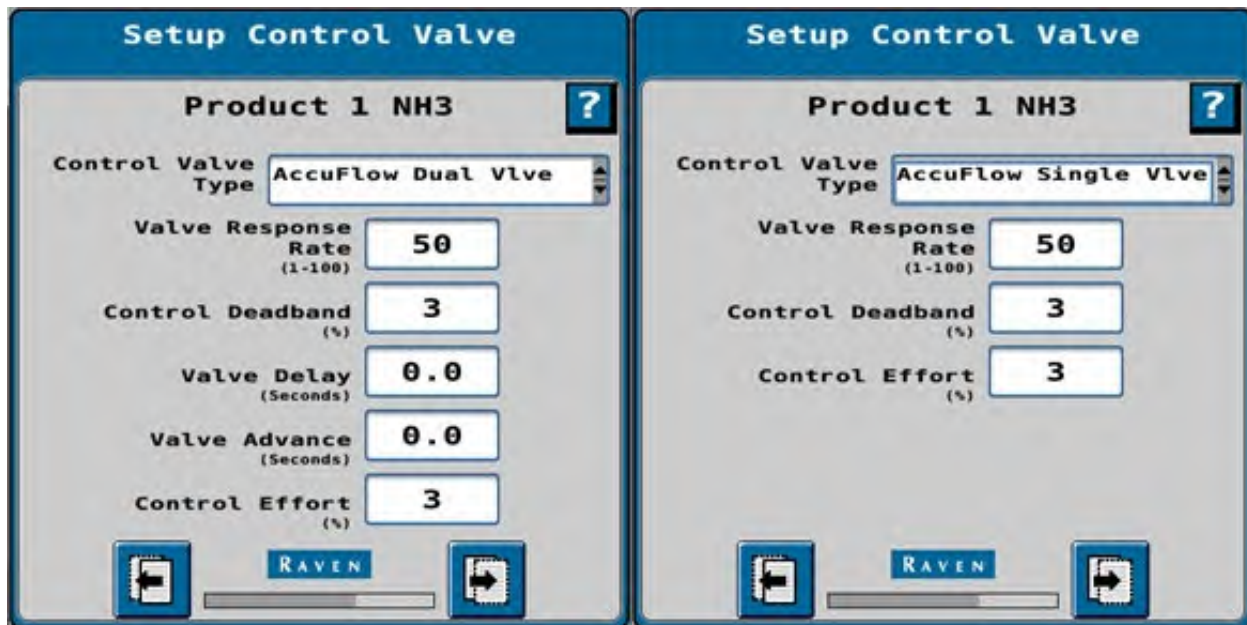

25. Press the Next Page icon.

26. Enter the Flowmeter Calibration number. This is unique to each Flowmeter. Check the tag on the flow meter to find the value.

27. Press the Next Page icon.



Raven RCM Guide (continued)

28. Enter the Tank Capacity, Current Tank Level, and Low Tank Level values.
29. If desired, select the Alarm? Checkbox to be notified when the tank fill level falls below the low tank level threshold.
30. Press the Next Page icon.

Setup Tank/Bin

Product 1 NH3

Tank Capacity (lb N)

Current Tank Level (%)

Low Tank Level (%) Alarm?

Navigation: Back, RAVEN, Next Page

31. "Setup Rates" page controls the application rates for speed and determines how much product is being applied for Product 1. Enter three Preset Rate Values, as desired, which can be clicked between on the home screen. On the home screen, target rates can be entered as well.
32. Enter Rate Bump value in an increment as desired.
33. For Rate Selection, select "Predefined or Rx". This enables selection of rate from the preset value choices or from a prescription map that is imported from a Universal Terminal.
34. Check Display Smoothing.
35. Press the Next Page icon.

Setup Rates

Product 1 NH3 ?

	Rate 1	Rate 2	Rate 3
Preset Rate Values (Lbs N/Ac)	<input type="text" value="100"/>	<input type="text" value="125"/>	<input type="text" value="150"/>
Rate Bump (Lbs N/Ac)	<input type="text" value="10"/>		
Rate Selection	<input type="text" value="Predefined or Rx"/>		
Display Smoothing	<input checked="" type="checkbox"/>		

Navigation: Back, RAVEN, Next Page

Raven RCM Guide (continued)

36. Enter 20 for Off Rate Alarm and check Alarm? box.

NOTE: Alarm prompts when over 20% off target rate.

37. Make sure Section Valve Status Feedback Alarm is unchecked.

38. Press the Next Page icon.

Setup Alarms

Product 1 NH3 ?

Off Rate Alarm (% off target rate) Alarm?

Section Valve Status Feedback Alarm

Navigation icons: [Previous Page] [RAVEN] [Next Page]

39. No action required on this screen. Shows the setup summary. Make sure all the values are correct.

40. Press the Next Page icon to finish the RCM set-up

Setup Summary

Profile Name NH3

Machine Type NH3 Tool

Number of Products 1

Number of Sections 5

Implement Width (in) 750

Switchbox Present No

Navigation icons: [Previous Page] [RAVEN] [Next Page]

Raven RCM Guide (continued)

Flow Meter Calibration

Flow Meter Calibration can be accomplished using the Applied Product Calibration. This calibration should only be done if the applied lbs of N is varying greatly from actual applied lbs of N.

1. Navigate to the settings page and select the System Settings tab.

2. Touch the Rate Sensor Setup button.

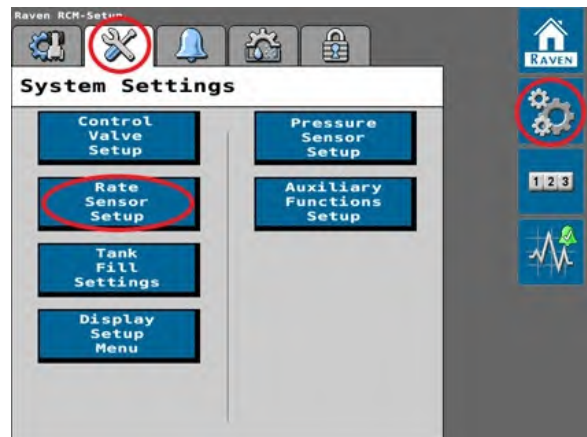

3. Touch the Applied Product Calibration button.

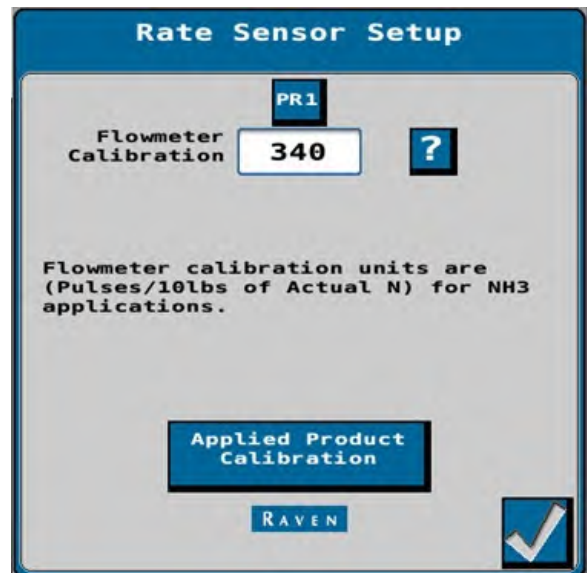

Raven RCM Guide (continued)

4. Read the calibration directions carefully.
Touch the blue checkmark.



5. Touch Stop Accumulating when complete.
6. Follow on screen steps to finish calibration.

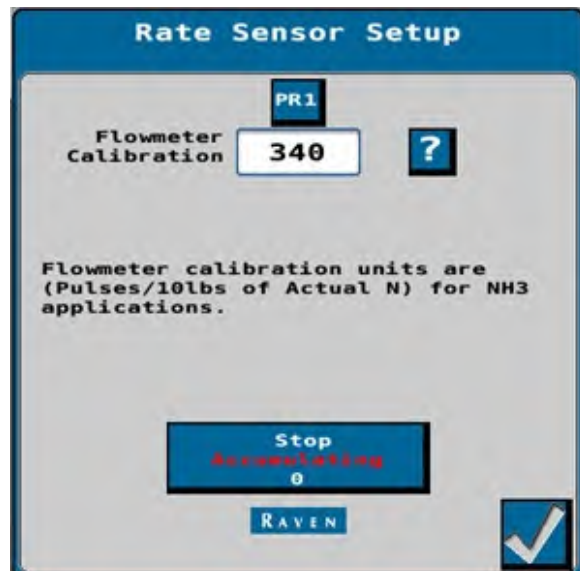

Raven RCM Guide (continued)

Energize System

An energize system test allows the operator to pressurize the system after connecting to a new nurse tank or re-energizing the system to begin a job.

1. Navigate to the Diagnostics page and select the Tests tab.

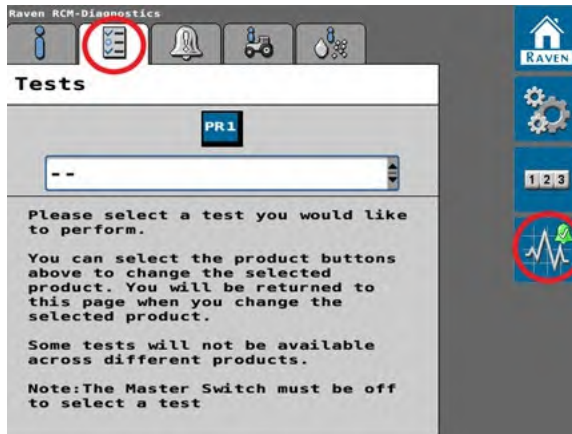

2. Select “Energize System” from the drop down menu.

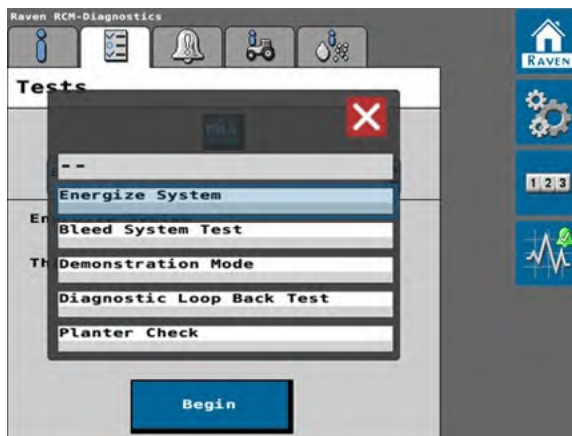

Raven RCM Guide (continued)

3. Press begin to start the process. A warning alarm will pop up saying that the test will discharge anhydrous ammonia. Make sure to read the warning carefully. Touch the green checkmark.

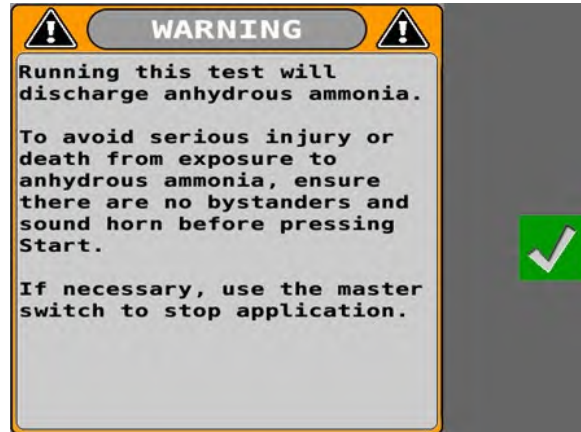

4. Before starting to energize the system, read the directions carefully to ensure proper safety.
5. Touch start and open the individual section valves to energize the system.
6. Repeat as necessary until anhydrous ammonia is being applied by all rows.

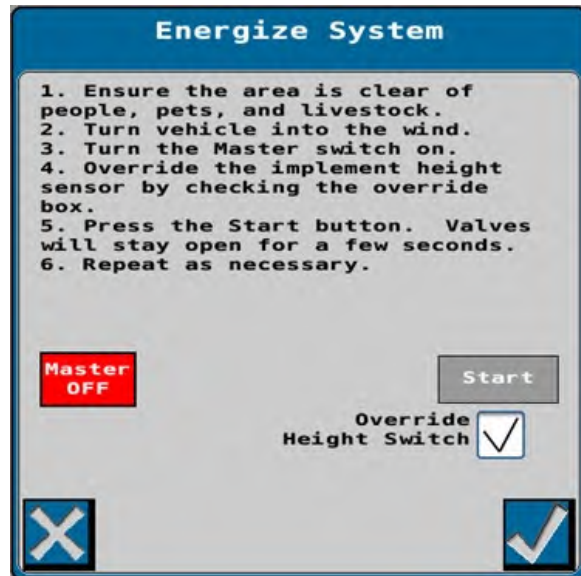

Raven RCM Guide (continued)

Bleed System Test

A Bleed System Test allows the operator to bleed the system after the nurse tanks have been disconnected.

NOTE: The bleed system test will not evacuate all of the NH3 entirely. Perform the manual bleed procedure for the system to ensure NH3 is completely evacuated.

1. Navigate to the Diagnostics page and select the Tests tab.

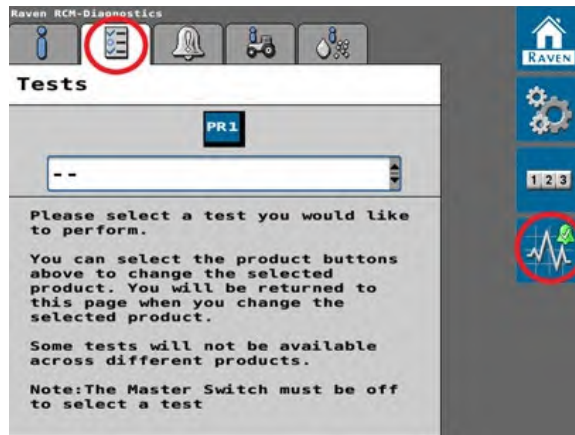

2. Select "Bleed System Test" from the drop down menu.

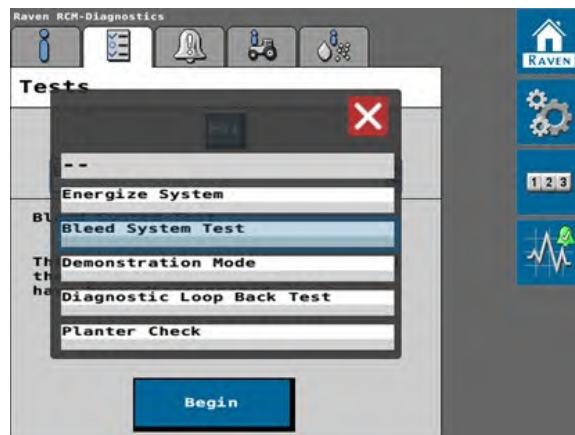

Raven RCM Guide (continued)

3. Press begin to start the process. A warning alarm will pop up saying that the test will discharge anhydrous ammonia. Make sure to read the warning carefully. Touch the green checkmark.

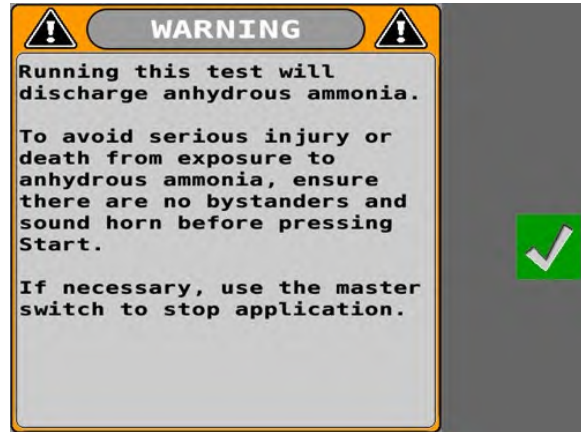

4. Before starting to bleed the system, read the directions carefully to ensure proper safety.
5. Touch start and open the individual section valves to bleed each section.

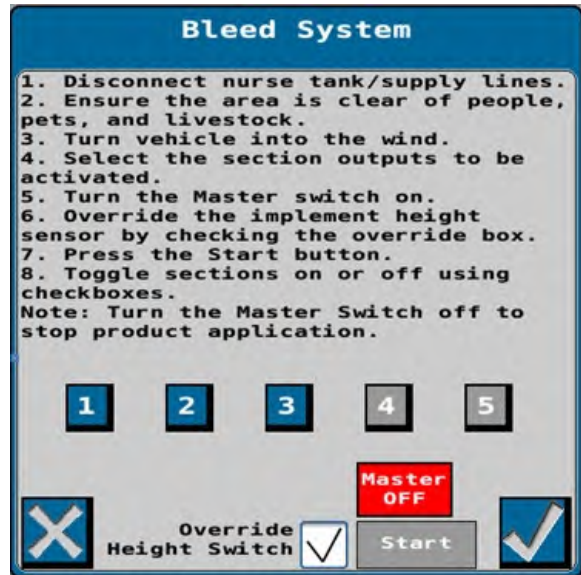

SECTION III

Operation

Preparing Tractor	3-2
Preparing Applicator.....	3-2
Hardware.....	3-2
Pivot Pins	3-2
Hitch	3-2
Hydraulic System.....	3-2
Tires/Wheels.....	3-3
Lubrication	3-3
Hitching to the Tractor.....	3-4
Drawbar Hitching.....	3-4
Transport Chain	3-5
Hydraulic Connections.....	3-6
Electrical Connection	3-6
Jack Usage.....	3-7
Parked Position.....	3-7
Transport Position	3-7
Transporting	3-8
Drawbar Connection	3-8
Toolbar Operation.....	3-9
Leveling Machine.....	3-9
Leveling Adjustable Gauge Wheels.....	3-10
Pin Adjust Gauge Wheels.....	3-11
Depth Adjustment	3-12
Locking Depth Adjustment Linkage.....	3-12
Hydraulic System Charging.....	3-13
Folding Toolbar.....	3-14
Nurse Tank Hitch.....	3-15
Anhydrous Ammonia Operating Instructions	3-16
Checking System.....	3-16
Connecting Nurse Tank	3-16
Disconnecting Nurse Tank	3-17
Coupler Operations	3-18
Orifice Block Setting.....	3-20
Clean Water Tank	3-21
Torsion Arm Basket (Options).....	3-21
SuperShooter (Options)	3-22
MaxPac AR700 (Options)	3-22
Residue Manager (Options).....	3-22

Preparing Tractor

Before operating applicator, read the tractor operator's manual and gain an understanding of its safe methods of operation.

Check the tractor brakes and transport lights. Make sure they are in proper working order.

Check the tractor hydraulic oil reservoir and add oil if needed.

Verify that the tractor is adequately ballasted for drawbar operation at the anticipated draft and vertical tongue load. Vertical tongue load of a loaded applicator is approximately 8,500 lbs. unfolded (4800 lbs. with toolbars folded to transport position). Ensure that the tractor's drawbar has sufficient strength to support this load.

If possible, adjust the tractor drawbar vertically so the top side of the drawbar is at least 18 inches from the ground. Alternately, the applicator hitch may be adjusted vertically by choosing other mounting holes provided.

Raise and secure all tractor 3-point hitch linkage to prevent interference with the implement tongue and hydraulic hoses during turning.

Preparing Applicator

Perform the service checks as outlined. Repair or replace any damaged or worn parts before operating.

Hardware

Check for loose bolts and nuts, and tighten as needed. Check again after the first half-day of operation.

Pivot Pins

Check that all pins are in place and in good condition. Replace any worn, damaged or missing pins.

Hitch

Check hitch and hitch retention hardware for damage and wear.

Hydraulic System

Check all hoses and cylinders for signs of leakage. Hoses should not be kinked, twisted or rubbing against sharp edges. Re-route or repair hoses as necessary. Refer to SAFETY section for additional information on safe repair and inspection of hydraulic components.

Preparing Applicator (continued)

Tires/Wheels

Check tire pressures and maintain at recommended values listed in the MAINTENANCE section.

CAUTION

- **IMPROPERLY TORQUED WHEEL NUTS/BOLTS CAN CAUSE A LOSS OF IMPLEMENT CONTROL AND MACHINE DAMAGE. WHEEL NUTS/BOLTS MUST BE CHECKED REGULARLY. SEE TORQUE PAGE IN THE “MAINTENANCE” SECTION FOR PROPER WHEEL NUT/BOLT SPECIFICATIONS. WARRANTY DOES NOT COVER FAILURES CAUSED BY IMPROPERLY TORQUED WHEEL NUTS/BOLTS.**

IMPORTANT

- *Installing wheels without the proper inset could result in hub or spindle failure. This will cause substantial damage to the applicator.*

For questions regarding new tire warranty, please contact your local original equipment tire dealer. Used tires carry no warranty. Tire manufacturers' phone numbers and web sites are listed in the “MAINTENANCE” section for your convenience.

Lubrication

Lubricate the applicator as outlined in the MAINTENANCE section.

Hitching to the Tractor

Drawbar Hitching

WARNING

- **DO NOT STAND BETWEEN THE IMPLEMENT AND TRACTOR WHEN HITCHING. ALWAYS ENGAGE PARKING BRAKE AND STOP ENGINE BEFORE INSERTING HITCH PIN.**

Connect the hitch to the tractor drawbar. Do not attempt to hitch to any other location on the tractor. (FIG. 3-1)

NOTE: Only use the centered position on the drawbar.

The implement is equipped with a single tang ball swivel hitch (JAP3232) and requires a 2" diameter drawbar pin. Clevis hitch (JAM2144) requires a 1 1/4" diameter drawbar pin.

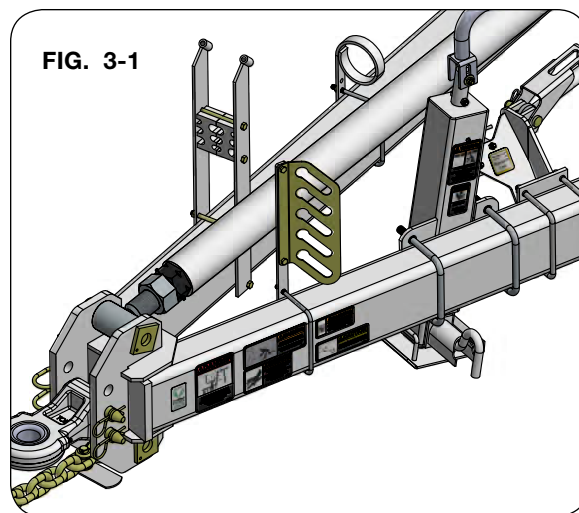

IMPORTANT

- *The use of a smaller-diameter hitch pin will result in additional clearance between the implement hitch and pin. This additional clearance may cause accelerated pin and hitch wear, along with more pronounced jolting from the implement during operation.*

Hitching to the Tractor (continued)

Transport Chain

Always use a transport chain when connecting the implement directly to a tractor. Make sure the intermediate chain support is in use. **DO NOT** use the intermediate chain support as the chain attaching point. FIG. 3-2 shows how the transport chain must be installed between the tractor and implement.

Transport chain should have a minimum rating equal to the gross weight of the implement and all attachments. Use only ASABE approved chain. Allow no more slack in the chain than necessary to permit turning.

Transport chain connection shown for illustration purposes only. Refer to tractor manufacturer for proper attachment.

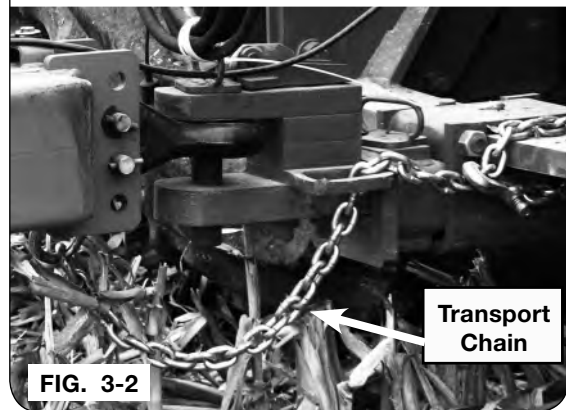

CAUTION

- REPLACE TRANSPORT CHAIN IF ANY LINK OR END FITTING IS BROKEN, STRETCHED OR DAMAGED. DO NOT WELD TRANSPORT CHAIN.

Hitching to the Tractor (continued)

Hydraulic Connections

After cleaning hydraulic hose couplers, connect to tractor hydraulic circuits.

CAUTION

- **DO NOT UNFOLD OR FOLD TOOLBAR WITHOUT HITCHING TO THE TRACTOR.**

1. Connect the toolbar hydraulic hoses to the tractor remote couplers. The 1/2" hoses supply oil to the toolbar lift cylinders. The 3/8" hoses supply oil to the wing fold cylinders.

NOTE: Always connect the hoses so the toolbar raises when the tractor remote control lever is moved rearward and lowers when the lever is moved forward.

Refer to the MAINTENANCE SECTION for flow diverter valve setup information.

Before disconnecting hoses from the tractor, relieve pressure from the lines. See tractor's operators manual for proper procedure to relieve pressure.

WARNING

- **AFTER INITIAL SET-UP OR REPLACEMENT OF ANY HYDRAULIC COMPONENT ON THE APPLICATOR, AIR MUST BE REMOVED FROM THE WING-FOLD HYDRAULIC SYSTEM PRIOR TO ITS FIRST USE. FAILURE TO DO SO MAY RESULT IN DAMAGE TO TOOLBAR COMPONENTS DUE TO RAPID MOVEMENT.**

Electrical Connection

The main harness has a 7-pin (round) plug conforming to SAE standards that connects to tractor. If your tractor does not have the mating socket connector, contact your tractor dealer. (FIG. 3-3)

The wiring schematic for this applicator, as shown in the maintenance section, complies with current ASABE standards. Always verify correct electrical function before using this applicator.

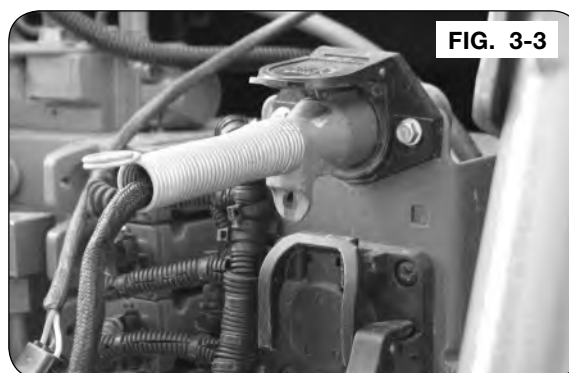
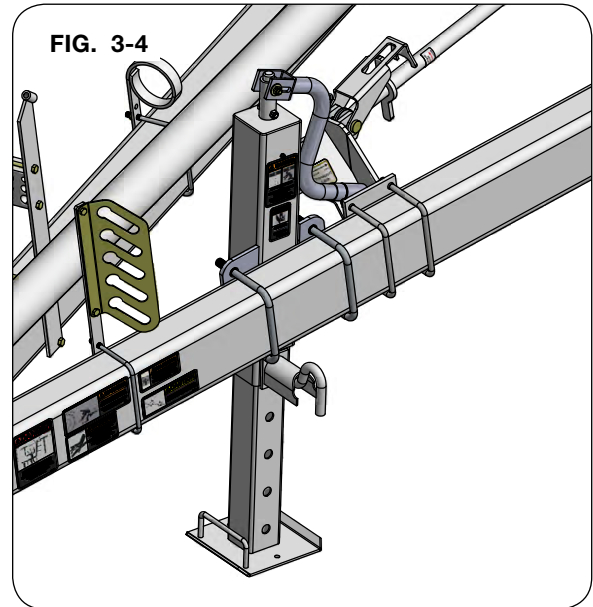

FIG. 3-3

Jack Usage

Parked Position

Lower drop leg to contact the ground. Crank jack leg downward to completely remove the hitch weight from tractor drawbar. (FIG. 3-4)



Transport Position

After tractor connection is established, raise jack leg of the jack to highest position to maximize ground clearance. (FIG. 3-5)

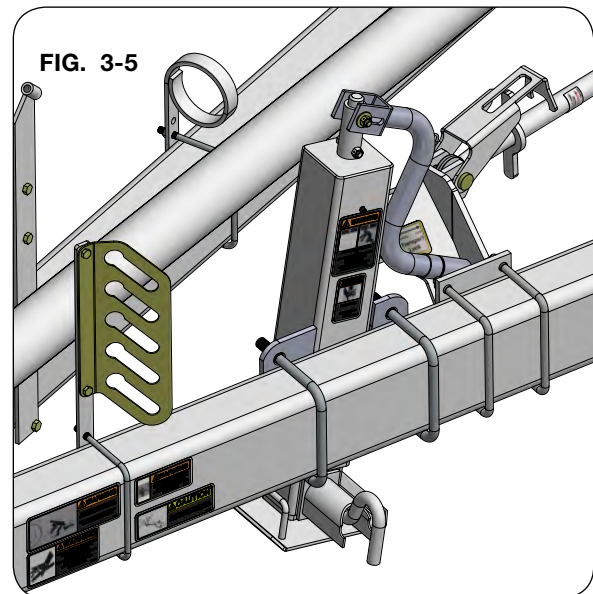

Transporting

Drawbar Connection

CAUTION

- THIS IMPLEMENT IS NOT EQUIPPED WITH BRAKES. ENSURE THAT THE TOWING VEHICLE HAS ADEQUATE WEIGHT AND BRAKING CAPACITY TO TOW THIS IMPLEMENT.
- IMMEDIATELY PRIOR TO ROAD TRANSPORT, RUN THE FULL FOLD SEQUENCE FOR PROPER SYSTEM PRESSURES AND TO AVOID INADVERTENT MOVEMENT.

See towing vehicle manual for towing and braking capacity. Regulate speed to road conditions. Maximum speed of applicator with wheels should never exceed 20 m.p.h.

Secure drawbar pin with a locking device and lock tractor drawbar in centered position.

Secure transport chain to tractor before transporting. Use good judgment when transporting equipment on highways. Regulate speed to road conditions and maintain complete control.

It is probable that this implement is taller, wider, and longer than the towing tractor. Become aware of and avoid all obstacles and hazards in the travel path of the equipment, such as power lines, ditches, etc.

Slow down before making sharp turns to avoid tipping. Drive slowly over rough ground and side slopes.

Toolbar Operation

DANGER

- PERFORM FRAME UNFOLDING AND FOLDING OPERATIONS ONLY IN AREAS WITH ADEQUATE HEIGHT, WIDTH AND LENGTH CLEARANCES. IN PARTICULAR, BE MINDFUL OF LOCATION OF OVERHEAD POWER LINES. FAILURE TO DO SO CAN RESULT IN PERSONAL INJURY AND PROPERTY DAMAGE.

WARNING

- KEEP ALL PERSONNEL A SAFE DISTANCE AWAY FROM THE IMPLEMENT WHEN UNFOLDING OR FOLDING THE TOOLBAR. PERSONAL INJURY CAN RESULT FROM IMPACT WITH FRAME.
- DO NOT EXCEED 10 MPH DURING OFF-HIGHWAY TRAVEL.

Toolbar Operation (continued)

Leveling Machine

IMPORTANT

- *Never unfold the unit without attaching to tractor first. Refer to “Hitching to the Tractor” and “Jack Usage” in this section.*
1. Before leveling the machine the tire pressure should be checked. Inflate center section lugged tractor tires to 51 PSI maximum; truck tires 95 PSI maximum.

Before beginning operation of this machine the main frame must be level. Place toolbar on level surface. Use the turnbuckle wrench to loosen the lower turnbuckle jam nut. Adjust turnbuckle with wrench until the main frame is level front to back. After making the necessary adjustment, lock turnbuckle with jam nut.

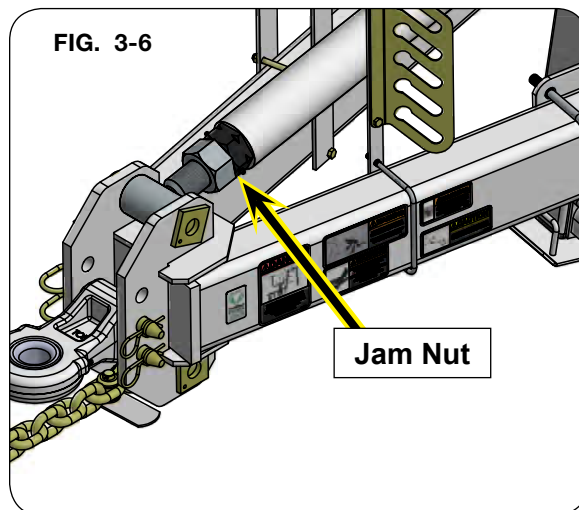

2. Unlock transport lock before unfolding toolbar.

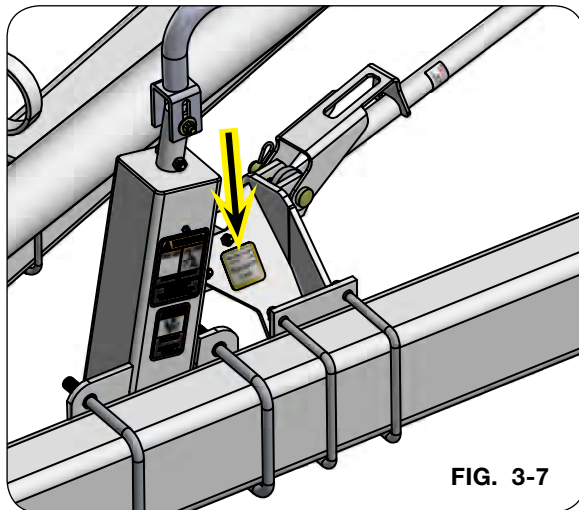

Toolbar Operation (continued)

Leveling Adjustable Gauge Wheels

NOTE: Adjust until toolbar is level across the entire bar

1. Check tire pressure before adjusting. Loosen the two 1" x 4" hex bolts at the top of the adjust linkage. Loosen 1" hex nut on inside of threaded rod. Turn 1" hex nut on outside clockwise to lower wing and counter clockwise to raise wing. Secure both nuts on threaded rod against cylinder lug adjust. Tighten 1" x 4" hex cap screws after wheel adjustment.

NOTE: Coulter will require final working depth adjustment in the field.

Tighten one inch hex nuts after wheel adjustment.

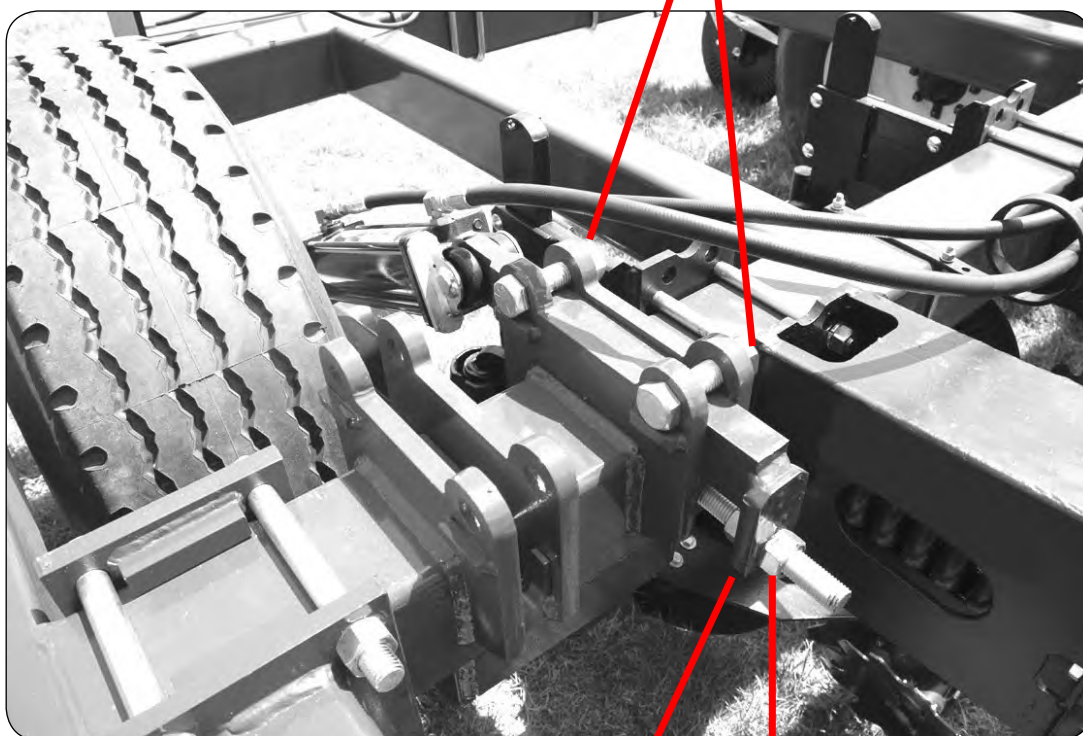

Cylinder lug adjust

One inch hex nut

FIG. 3-8

Toolbar Operation (continued)

Pin Adjust Gauge Wheels

1. Adjust pin adjust gauge wheel to level position with the hydraulic gauge wheel.

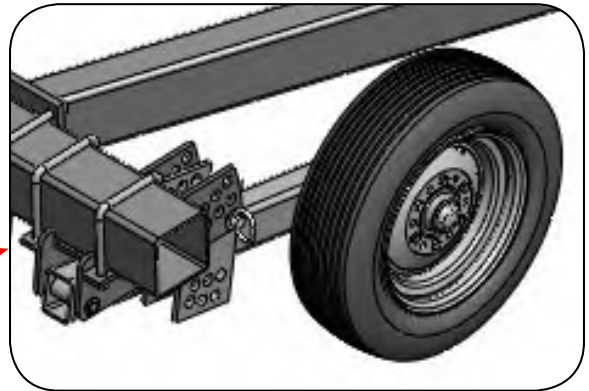
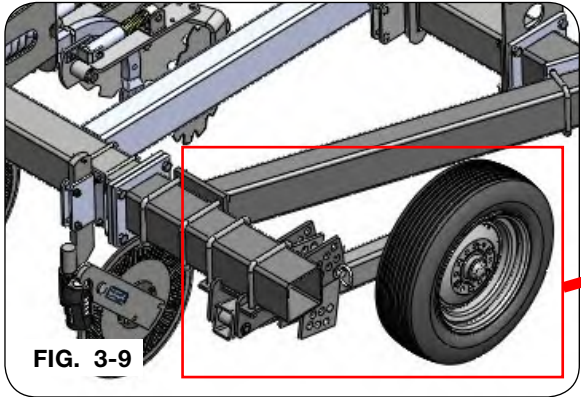

Toolbar Operation (continued)

Depth Adjustment

1. One complete revolution equals 1/2" of depth increase.

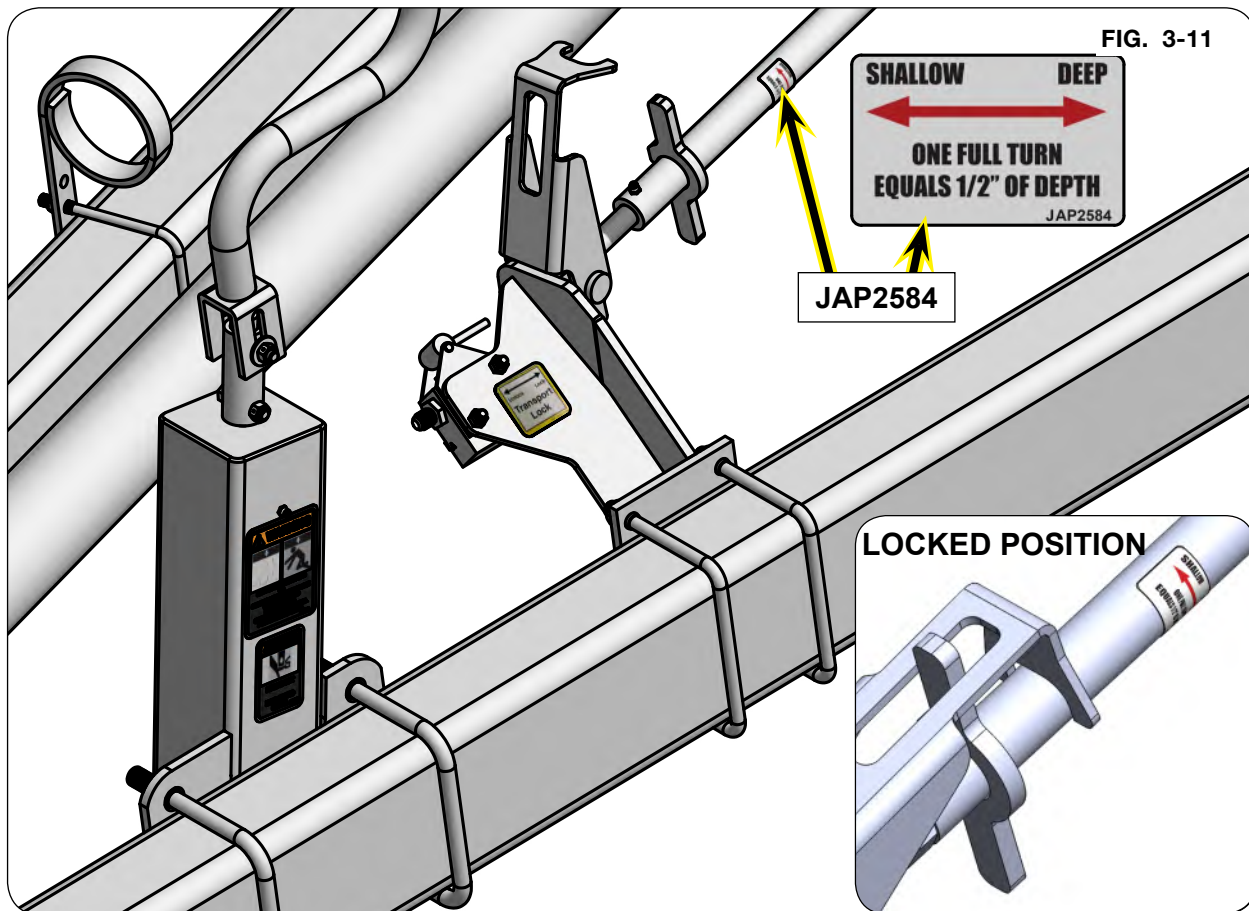

Locking Depth Adjustment Linkage

1. Rotate depth control adjuster latch over handle and lock in place with 1/4" x 2" wire retaining pin (JBP3376).

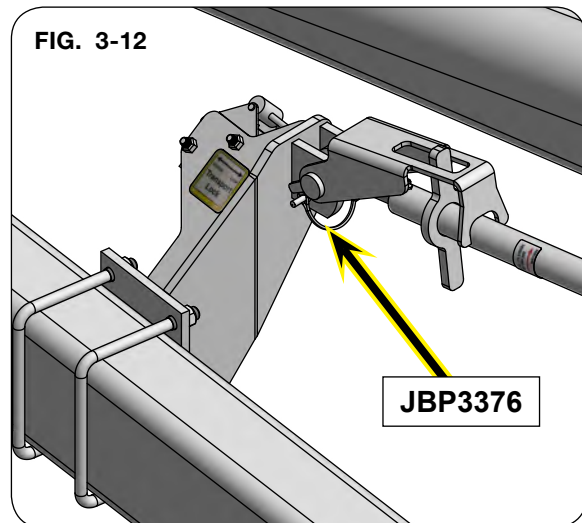

Hydraulic System Charging

WARNING

- ALWAYS RELIEVE HYDRAULIC SYSTEM PRESSURE BEFORE DISCONNECTING HOSES FROM TRACTOR OR SERVICING HYDRAULIC SYSTEM. SEE TRACTOR OPERATOR'S MANUAL FOR PROPER PROCEDURES.
- HYDRAULIC SYSTEM MUST BE PURGED OF AIR BEFORE OPERATING TO PREVENT SERIOUS INJURY OR DEATH.
- HIGH-PRESSURE FLUIDS CAN PENETRATE THE SKIN AND CAUSE SERIOUS INJURY OR DEATH. USE CARDBOARD OR WOOD TO DETECT LEAKS IN THE HYDRAULIC SYSTEM. SEEK MEDICAL TREATMENT IMMEDIATELY IF INJURED BY HIGH-PRESSURE FLUIDS.

NOTE: Refer to SETUP section for purging process.

Connecting Hydraulic Hoses to Tractor

1. Connect the hydraulic hoses to the tractor remote couplers. The 1/2" hoses supply oil to the wheel lift cylinders. The 3/8" hoses supply oil to the wing cylinders. Mark hose pairs with paint or tape. Mark hoses so that they are plugged in correctly each time.
2. Hook implement to tractor. Connect the hydraulic lines to tractor ports.

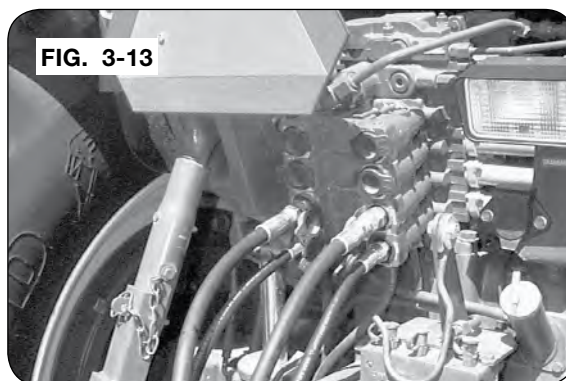

GENERIC EXAMPLE

Folding Toolbar

1. Fold slowly! Check hoses, fittings and row mountings for folding interference or leaks.



FIG. 3-14

21 Row 30" Spacing
Shown

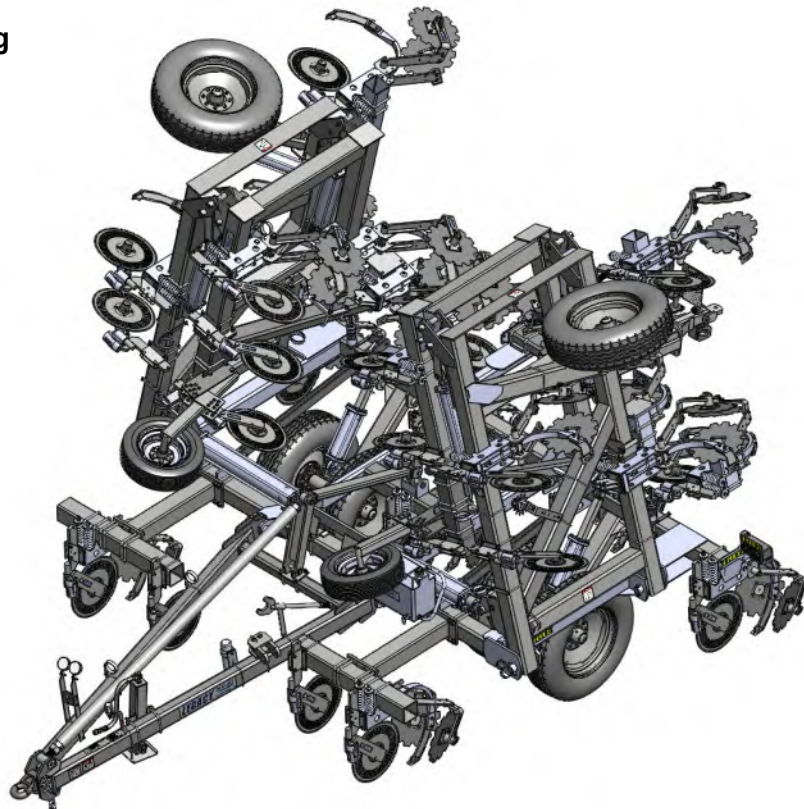

FIG. 3-15

Nurse Tank Hitch

1. Nurse tank hitch can be retracted and moved from side to side for easy hookup. Hitch will automatically lock in the extended position.

NOTE: Periodically check latch mechanism to ensure proper latching in the extended position.

2. Mechanism must swing freely in order to operate properly. Installed position must be squared with frame to allow maximum freedom of movement. Keep soil and debris from area to allow maximum movement.

NOTE: After seasonal storage, check wing latch for freedom of movement.

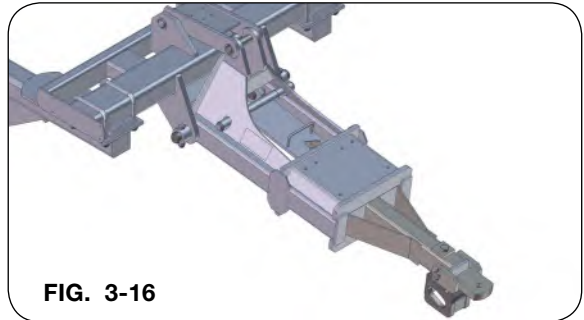

FIG. 3-16

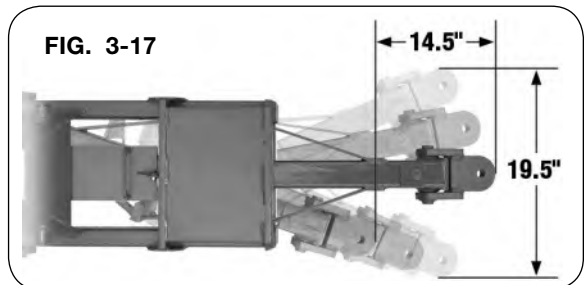

FIG. 3-17

Anhydrous Ammonia Operating Instructions

⚠ WARNING

- ALWAYS WEAR PERSONAL PROTECTIVE EQUIPMENT WHEN WORKING WITH OR NEAR CHEMICALS. THIS EQUIPMENT INCLUDES, BUT IS NOT LIMITED TO: PROTECTIVE EYE WEAR, GLOVES, SHOES, SOCKS, LONG-SLEEVED SHIRT, AND LONG PANTS. ADDITIONAL PROTECTION MAY BE REQUIRED FOR MANY TYPES OF CHEMICALS.
- POSITION YOUR BODY AWAY FROM THE BLEED VALVE EXIT HOLE TO AVOID CONTACT WITH ANHYDROUS AMMONIA WHEN BLEED VALVE IS OPENED. CONTACT WITH SKIN WILL CAUSE SEVERE CHEMICAL BURNS.
- AVOID BREATHING AMMONIA VAPORS. CLEAR ALL PERSONNEL FROM THE AREA BEFORE OPENING SYSTEM. INHALATION OF VAPORS WILL IRRITATE OR DAMAGE RESPIRATORY TRACT AND LUNGS, RESULTING IN INJURY OR DEATH.

IMPORTANT

- Attend Anhydrous Ammonia Safety Training Class Before Operating This Equipment.

NOTE: In case of exposure, have a minimum of 5 gallons of flushing water available at all times.

Checking System

With personal protective equipment in place, visually inspect the toolbar and system components for integrity, includes hoses that may be subject to inadvertent contact with structural surfaces resulting in premature exterior hose deterioration.

Connecting Nurse Tank

Hitch the nurse tank to the toolbar using a keyed hitch pin. Affix wagon tongue transport chains securely to nurse tank chain loops provided.

Carefully hand tighten the nurse tank supply hose connection. Position hose to allow unobstructed movement in case of Nurse Tank break away. Do not allow supply hose to contact surfaces that may cause abrasion or wear including sharp corners, soil or roads.

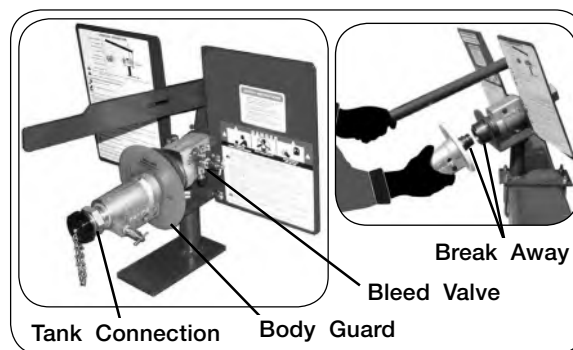

Confirm the functional operation of the break away coupler on a daily basis. First bleed pressure off of tank supply hose and 1-1/4" quick coupler using the bleed valves provided. Sharply pull on the tank supply hose. The coupler mechanism should release under these forces. Visually inspect coupler for corrosion, foreign elements and proper seating of mating poppets.

DO NOT transport equipment from field to field with tank and supply line valves open. When immediately ready for field application, beginning at the tank, and with personal protective equipment in place, slowly open all supply line valves.

Anhydrous Ammonia Operating Instructions (continued)

Disconnecting Nurse Tank

WARNING

- ALWAYS WEAR PERSONAL PROTECTIVE EQUIPMENT WHEN WORKING WITH OR NEAR CHEMICALS. THIS EQUIPMENT INCLUDES, BUT IS NOT LIMITED TO: PROTECTIVE EYE WEAR, GLOVES, SHOES, SOCKS, LONG-SLEEVED SHIRT, AND LONG PANTS. ADDITIONAL PROTECTION MAY BE REQUIRED FOR MANY TYPES OF CHEMICALS.
-

CAUTION

- FIFTH WHEEL STYLE RUNNING GEAR FRONT AXLES MAY INADVERTENTLY ROTATE IN UNEVEN SOIL CONDITIONS WHEN THE HITCH PIN IS PULLED CAUSING THE TONGUE TO COME INTO CONTACT AND POTENTIALLY INJURING THE OPERATOR.
-
1. With personal protective equipment in place, and beginning at the tank, fully shut off the supply hose valves. If the supply hose is a tank wagon component (as opposed to a toolbar component) an additional hand operated globe valve shut off located between the quick coupler and the Heat Exchanger feed line will significantly speed up the tank wagon change process.
 2. Clear all personnel from area except for the operator. While considering the direction of the wind to avoid ammonia vapor drift toward the operator or any other personnel, beginning at the tank, slowly open supply line bleed valves to release pressure from the hose.
 3. Physically grasp, lift and lightly shake the supply hose mid section to insure total evacuation of ammonia. Once again, be wary of the wind direction.
 4. Place the supply hose in a transport storage position, preventing it from becoming entangled or in contact with sharp edges or abrasive surfaces.
 5. Always park and unhook the nurse tank on a smooth and level surface. Block the wheels to prevent tank wagon from rolling away. High winds or uneven terrain can cause unblocked tank wagons to move out of control.
 6. Disconnect tank wagon tongue transport chains, hitch pin key and hitch pin.

Coupler Operations

⚠ WARNING

- ALWAYS WEAR PERSONAL PROTECTIVE EQUIPMENT WHEN WORKING WITH OR NEAR CHEMICALS. THIS EQUIPMENT INCLUDES, BUT IS NOT LIMITED TO: PROTECTIVE EYE WEAR, GLOVES, SHOES, SOCKS, LONG-SLEEVED SHIRT, AND LONG PANTS. ADDITIONAL PROTECTION MAY BE REQUIRED FOR MANY TYPES OF CHEMICALS.

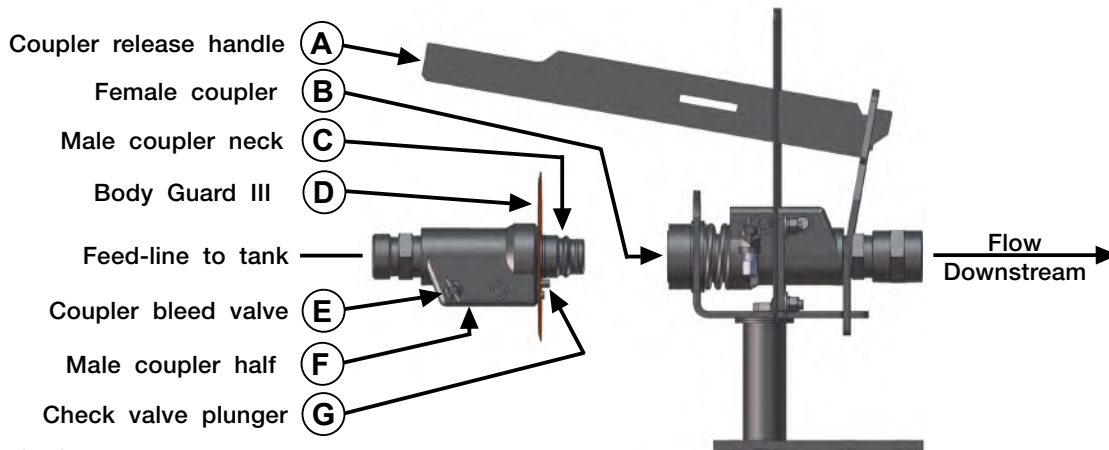

FIG. 3-18

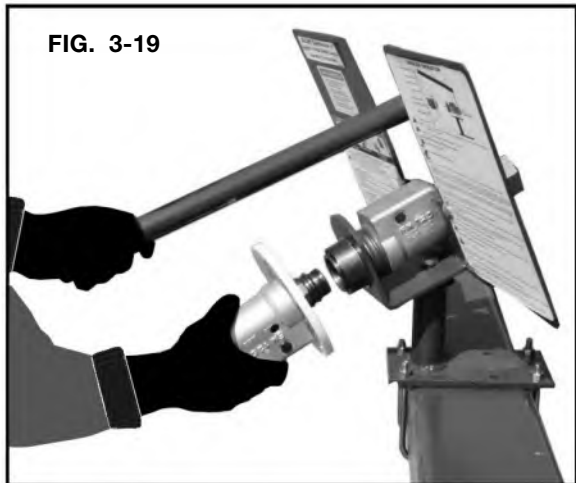

FIG. 3-19



FIG. 3-20

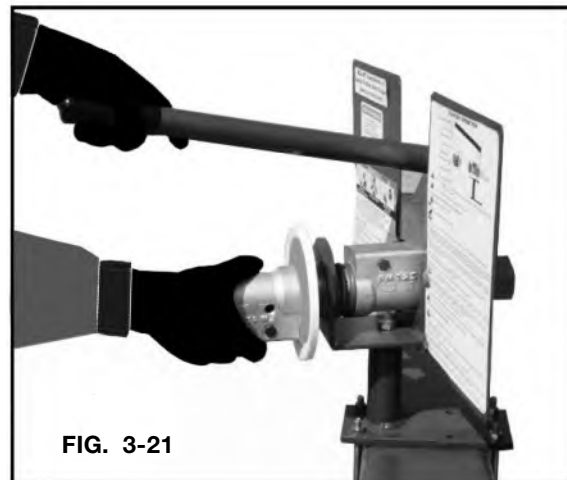

FIG. 3-21

Coupler Operations (continued)

Connecting

1. Stand on the upwind side. Close all feed-line valves and inspect all components for proper condition.
2. Relieve pressure in nurse tank hose between male coupler (F) and first shutoff valve towards nurse tank by carefully opening coupler bleed valve (E). The Squibb Flo-Max coupler is designed to re-couple safely with pressure on the female coupler half (B).

NOTE: Leave coupler bleed valve (E) open for now.

3. While holding and pointing the hose and male coupler (F) downwind and away from your person, depress check valve plunger (G) with gloved finger to ensure proper operation (FIG. 3-18). Wipe foreign debris from coupler neck (C) with clean cloth.
4. Make certain BodyGuard III (D) is installed fully with slot oriented around check valve plunger (G) to protect against ammonia spray-back during coupling (FIG. 3-18 & FIG. 3-19).
5. Insert male coupler neck (C) into female coupler half (B) as far as possible (FIG. 3-20).

NOTE: Then, while applying insertion pressure, pull downward on coupler release handle (A) to complete the coupling process. Release handle (A) after engagement of coupler neck (C) (FIG. 3-21).

6. Lightly pull on male coupler (F) to ensure proper engagement.
7. Close bleed valve (E) and others if open. Open tank and hose valves just prior to applying ammonia.

Disconnect

1. After closing all valves, bleed pressure from male coupler half (F) by opening coupler bleed valve (E). Leave bleed valve (E) open.
2. Then, pull down on coupler release handle (A) and remove male coupler half (F).

Orifice Block Setting

To minimize the amount of ammonia going out the dump lines, follow the chart below to determine the dump orifice hose barb to use and install. The chart is based on GPM, gallons per minute. Use the formula below to determine your GPM then refer to the chart for the recommended dump orifice hose barb needed for your application.

Toolbar width in feet X speed X actual lbs. N per acre X .1212 ÷ .82 ÷ 5.14 ÷ 60 = GPM

1-10 GPM	11-20 GPM	21 and UP GPM	N-Serve Users
A	B	C	D

NOTE: “D” orifice is only for users having problems with N-serve plugging up the heat exchanger.

TIP: If you find that your rate does not balance out, try changing the orifice to the next larger size orifice.

To set or change the orifice size, loosen the wing nut slightly, then turn the orifice disk to the desired orifice letter by looking into the sight hole then tighten the wing nut firmly.

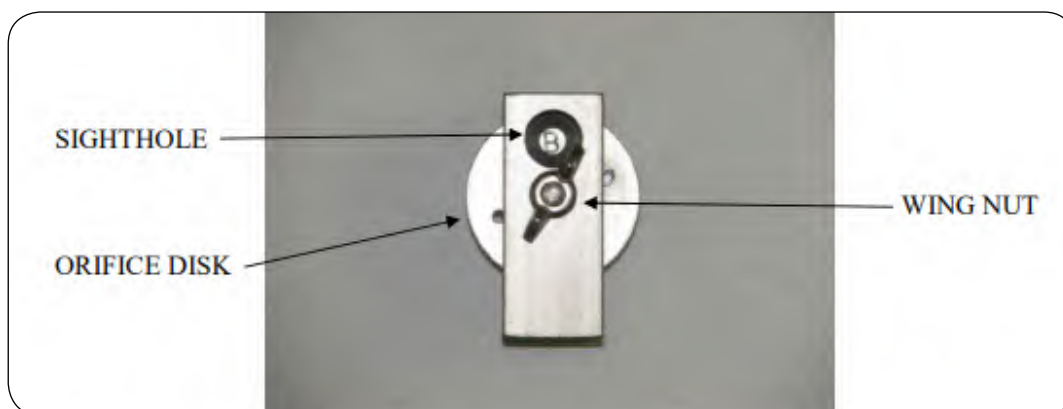

Clean Water Tank

Change water daily to provide fresh clean water to flush exposed skin or eyes. Drain water daily in cold temperatures to prevent freezing and bursting tank.

In case of exposure to anhydrous ammonia, open faucet or pull top end of hose loose to flush exposed part of body. Remove contaminated clothes as soon as possible. Seek medical attention.

NOTE: Clean Water Tank placement will depend on row spacing.



Torsion Arm Basket (Options)

See manual #J04000027 for complete operating procedures.

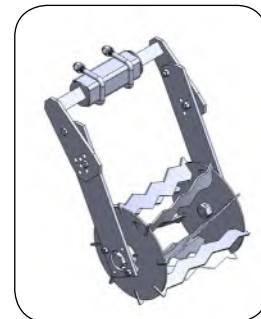

SuperShooter (Options)

See manual #J04000041 or J04000026 for complete operating procedures.

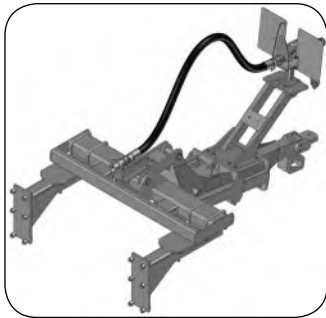

SUPERSHOOTER III
1 1/4" NPT OR 1 1/2" NPT
(MANUAL #J04000041)

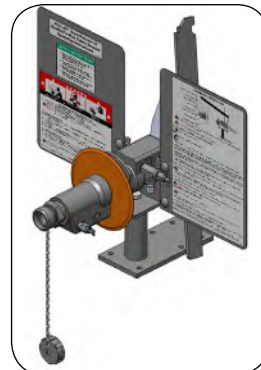
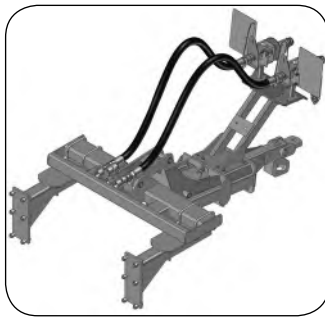

SUPERSHOOTER III
SQUIBB COUPLER
BODYGUARD III
(MANUAL #J04000026)

MaxPac AR700 (Options)

See manual #J04000028 for complete operating procedures.

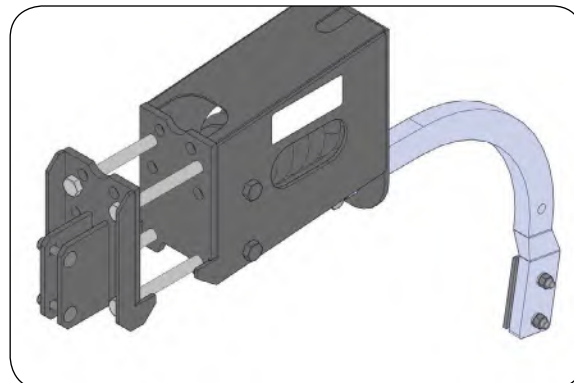

Residue Manager (Options)

See manual #J04000023 for complete operating procedures.



Section IV Maintenance

- Lubrication..... 4-2
- Legacy Maintenance..... 4-4
 - Seasonal Storage..... 4-4
 - Purging A Hydraulic System 4-5
- Schematics 4-6
- Wheel, Hub and Spindle Disassembly and Assembly 4-8
- Wheels and Tires..... 4-10
 - Wheel Nut Torque Requirements..... 4-10
 - Tire Pressure 4-11
 - Tire Warranty 4-11
- Complete Torque Chart 4-12
- Hydraulic Fittings - Torque and Installation 4-14
- NH3 Fittings - Torque and Installation..... 4-15

Lubrication

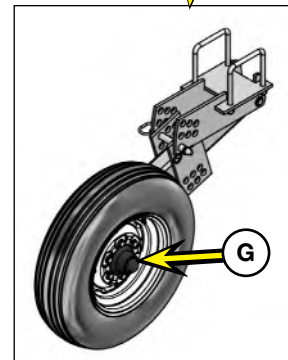
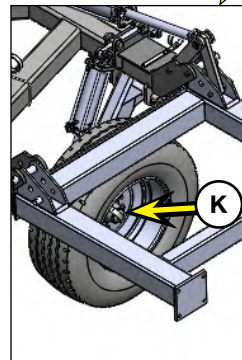
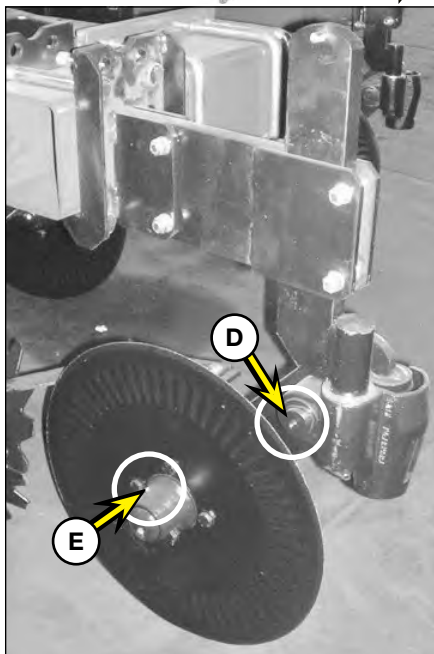
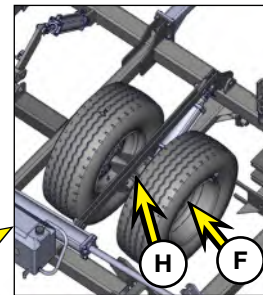
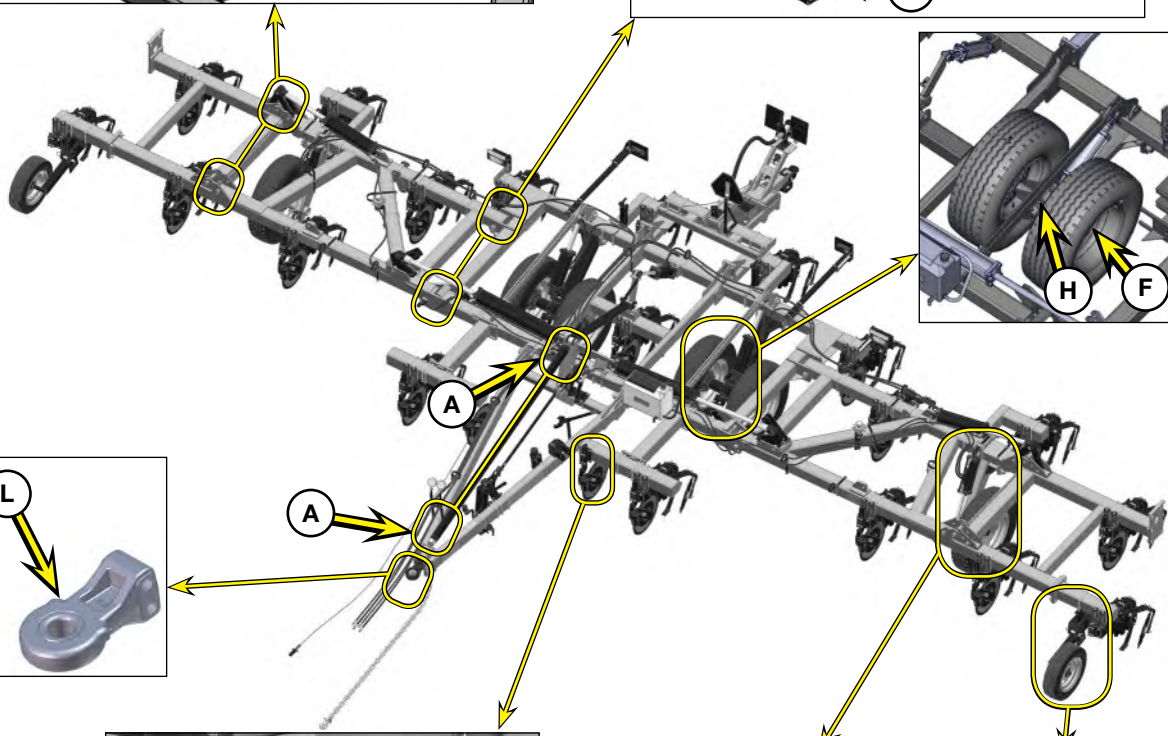
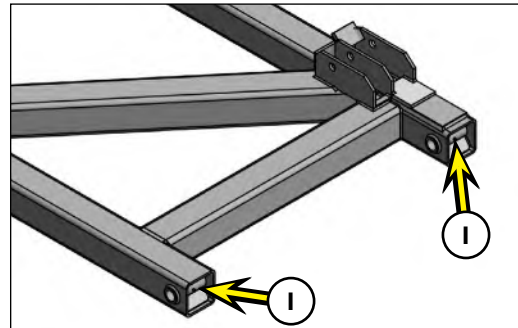
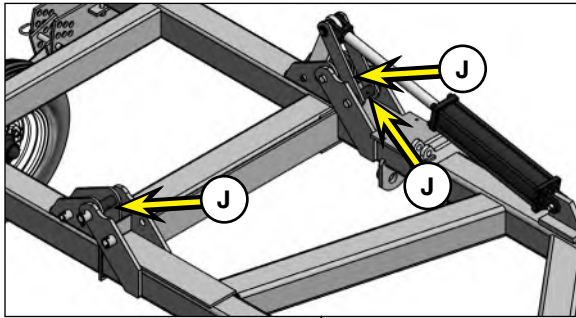

Lubrication (continued)

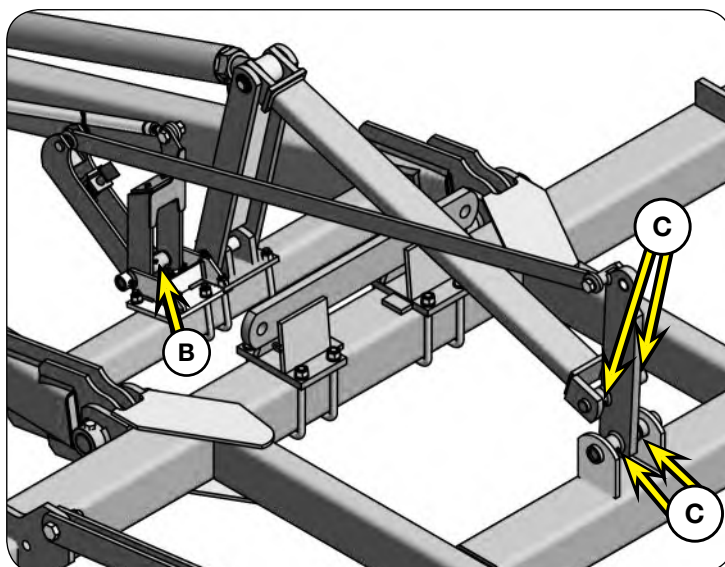

To keep your applicator in top operating condition and to assure its proper performance and reliability for a long period of time, periodic inspection and lubrication is a must.

Use EP-2 lubricant at the locations described in the chart.

All exposed cylinder rods should be coated with grease before seasonal storage to prevent rusting. Remove depth collars and lubricate exposed cylinder rods.

The lubrication locations and recommended schedule are as follows:

ITEM	DESCRIPTION	POINT	QTY.	HOURS
A	Depth Control Turnbuckle Assembly*	2	2 Shots	50 Hours
B	Stop Arm with Plunger Assembly	1	1 Shot	Weekly
C	Tongue Cylinder Arm Linkage	4	1 Shot	Weekly
D	Coulter Swivel	2	2 Shots	Weekly
E	Coulter Hub	-	10 Shots	Once Every Season
F	Main Frame Gauge Wheel Hub	2	Repack	Once Every Season
G	Secondary Wing Gauge Wheel Hub	2	Repack	Once Every Season
H	Main Frame Gauge Wheel Pivot	8	5 Shots	Weekly
I	Primary Wing Hinge	4	5 Shots	Weekly
J	Secondary Wing Hinge & Linkage	6	5 Shots	Weekly
K	Primary Wing Gauge Wheel Hub	2	Repack	Once Every Season
L	Hitch	2	2 Shots	Weekly

***NOTE - ITEM A:** Turn adjustable link two full turns in each direction to ensure threads do not seize.

Legacy Maintenance

DANGER

- ELECTROCUTION WILL CAUSE SERIOUS INJURY OR DEATH. THE IMPLEMENT IS NOT INSULATED. KEEP AWAY FROM ALL ELECTRICAL LINES AND DEVICES. ELECTROCUTION CAN OCCUR WITHOUT DIRECT CONTACT.
-

WARNING

- TIPPING OR MOVEMENT OF THE MACHINE CAN CAUSE SERIOUS INJURY OR DEATH. BE SURE MACHINE IS SECURELY BLOCKED.
 - EYE PROTECTION AND OTHER APPROPRIATE PERSONAL PROTECTIVE EQUIPMENT MUST BE WORN WHILE SERVICING IMPLEMENT.
 - KEEP HANDS CLEAR OF PINCH POINT AREAS.
 - ALWAYS WEAR PERSONAL PROTECTIVE EQUIPMENT WHEN WORKING WITH OR NEAR CHEMICALS. THIS EQUIPMENT INCLUDES, BUT IS NOT LIMITED TO: PROTECTIVE EYE WEAR, GLOVES, SHOES, SOCKS, LONG-SLEEVED SHIRT, AND LONG PANTS. ADDITIONAL PROTECTION MAY BE REQUIRED FOR MANY TYPES OF CHEMICALS.
 - AVOID BREATHING SPRAY MIST OR VAPOR.
 - WASH HANDS BEFORE EATING, DRINKING, CHEWING GUM, OR USING TOILET.
 - NEW HYDRAULIC SYSTEMS OR SYSTEMS THAT HAVE BEEN MAINTAINED MUST BE PURGED OF AIR BEFORE OPERATING OR MOVING MACHINE TO PREVENT SERIOUS INJURY OR DEATH.
-

CAUTION

- SHARP EDGES ON COULTER BLADES AND KNIVES CAN CAUSE SERIOUS INJURY. BE CAREFUL WHEN WORKING AROUND COULTER BLADES AND KNIVES.
-

Seasonal Storage

Check coultter swivel for wear. Replace as needed. See FIG. 4-1 on next page.

Always open all valves to remove any fluids and to allow moisture to dry.

Immediately after season is finished, completely wash machine to remove corrosive fertilizer inside and out before storing. When using pressure washers maintain an adequate distance so not to force water into bearings, hydraulic seals, or electrical connections.

Repaint all areas where paint has been removed to keep rust from developing. Coat areas of coultter blades and knives, if equipped, and coultter posts with rust preventative material.

Legacy Maintenance (continued)

Coat exposed cylinder piston rods with rust preventative material.

Inspect machine for parts that may need to be replaced so they may be ordered in the off season.

Lubricate machine at all points outlined.

Check coultter hubs for free rotation. If blade hubs do not rotate, replace and/or pack bearings with grease. Replace coultter arm if spindle is damaged. (FIG. 4-1)

Check coultter post swivel for free movement. If post swivel does not move, free the swivels and grease. Grease the coultter post swivel until fresh grease purges top or bottom of swivel casting to prevent the coultter pivot from seizing on post. (FIG. 4-1) Refer to "Lubrication" in this section.

After period of unused time, unit should be unfolded and refolded to check function of hydraulic system.

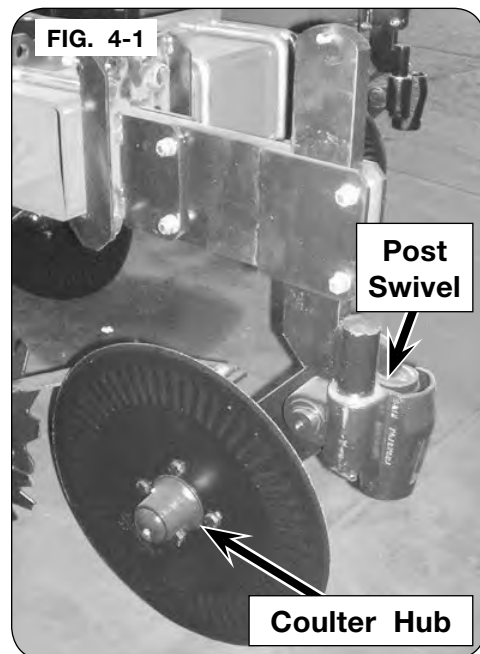

Purging A Hydraulic System

⚠ WARNING

- RELIEVE HYDRAULIC SYSTEM OF ALL PRESSURE BEFORE ADJUSTING OR SERVICING. SEE TRACTOR OPERATOR'S MANUAL FOR PROPER PROCEDURES.
- HIGH-PRESSURE FLUIDS CAN PENETRATE THE SKIN AND CAUSE SERIOUS INJURY OR DEATH. USE CARDBOARD OR WOOD TO DETECT LEAKS IN THE HYDRAULIC SYSTEM. SEEK MEDICAL TREATMENT IMMEDIATELY IF INJURED BY HIGH-PRESSURE FLUIDS.
- EYE PROTECTION AND OTHER APPROPRIATE PERSONAL PROTECTIVE EQUIPMENT MUST BE WORN WHILE SERVICING IMPLEMENT.

1. Purge air from system as follows:

- A. Disconnect the rod end of all cylinders in a circuit. Block up all rod end of each hydraulic cylinders in each circuit so the rod can completely extend and retract without contacting any other component.
- B. Pressurize the system and maintain system at full pressure for at least 5 seconds after cylinder rods stop moving. Check that all cylinders have fully extended or retracted.
- C. Check oil reservoir in hydraulic power source and re-fill as needed.
- D. Pressurize system again to reverse the motion of step B. Maintain pressure on system for at least 5 seconds after cylinder rods stop moving. Check that cylinders have fully extended or retracted.
- E. Check for hydraulic leaks using cardboard or wood. Tighten connections according to directions in Torque Specifications in MAINTENANCE section.
- F. Repeat steps B, C, D, and E 10-12 times.
- G. De-pressurize hydraulic system and connect cylinder rods clevises to their mating lugs.

Schematics - Electrical

Electrical Harness - Main 33' (JAP3221)

- A. CONNECTOR: 7 F-TERMINAL PLUG CONFORMING TO SAE J560
- B. CONNECTOR: PACKARD, FLAT 6 M-TERMINAL WEATHER-PACK SHROUD
- C. CONNECTOR: 7 M-TERMINAL SOCKET CONFORMING TO SAE J560
- D. CABLE: 5-WIRE 16AWG, (WHT, YEL, RED, GRN, BRN)
- E. TRAILER CABLE: 7-WIRE, 12AWG (BLK, YEL, GRN, BRN), 10AWG (RED, BLU), 8AWG (WHT)

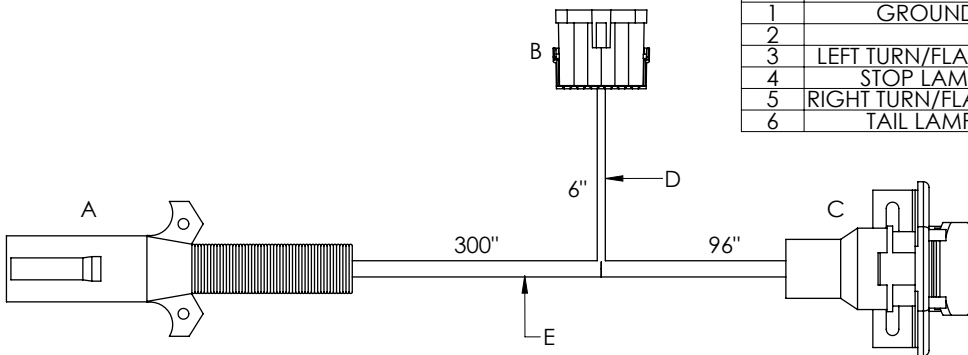

PIN #	DESCRIPTION	WIRE COLOR
1	GROUND	WHITE
2		
3	LEFT TURN/FLASHING	YELLOW
4	STOP LAMPS	RED
5	RIGHT TURN/FLASHING	GREEN
6	TAIL LAMPS	BROWN

7 F-TERMINAL SAE J560 PLUG		
PIN #	DESCRIPTION	WIRE COLOR
1	GROUND	WHITE
2	CLEARANCE/MARKER	BLACK
3	LEFT TURN/FLASHING	YELLOW
4	STOP LAMPS	RED
5	RIGHT TURN/FLASHING	GREEN
6	TAIL LAMPS	BROWN
7	AUX/ABS POWER	BLUE

7 M-TERMINAL SAE J560 SOCKET		
PIN #	DESCRIPTION	WIRE COLOR
1	GROUND	WHITE
2	CLEARANCE/MARKER	BLACK
3	LEFT TURN/FLASHING	YELLOW
4	STOP LAMPS	RED
5	RIGHT TURN/FLASHING	GREEN
6	TAIL LAMPS	BROWN
7	AUX/ABS POWER	BLUE

Electrical Harness - Rear 27' (JAP3222)

- A. CONNECTOR: PACKARD, FLAT 6-F TERMINAL WEATHER-PACK TOWER
- B. CONNECTOR: 3 M-TERMINAL RIGHT ANGLE LIGHT PLUG
- C. WIRE: 16AWG-COLORS: WHITE, YELLOW, RED, GREEN, BROWN

RIGHT REAR RED LAMP		
PIN #	DESCRIPTION	WIRE COLOR
1	GROUND	WHITE
2	STOP LAMPS	RED
3	TAIL LAMPS	BROWN

LEFT REAR RED LAMP		
PIN #	DESCRIPTION	WIRE COLOR
1	GROUND	WHITE
2	STOP LAMPS	RED
3	TAIL LAMPS	BROWN

RIGHT REAR AMBER LAMP		
PIN #	DESCRIPTION	WIRE COLOR
1	GROUND	WHITE
2	RIGHT TURN/FLASHING	GREEN

LEFT REAR AMBER LAMP		
PIN #	DESCRIPTION	WIRE COLOR
1	GROUND	WHITE
2	LEFT TURN/FLASHING	YELLOW

RIGHT FRONT AMBER LAMP		
PIN #	DESCRIPTION	WIRE COLOR
1	GROUND	WHITE
2	RIGHT TURN/FLASHING	GREEN

LEFT FRONT AMBER LAMP		
PIN #	DESCRIPTION	WIRE COLOR
1	GROUND	WHITE
2	LEFT TURN/FLASHING	YELLOW

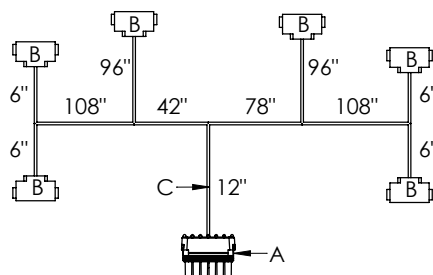

6 F-TERMINAL WEATHER-PACK TOWER		
PIN #	DESCRIPTION	WIRE COLOR
1	GROUND	WHITE
2		
3	LEFT TURN/FLASHING	YELLOW
4	STOP LAMPS	RED
5	RIGHT TURN/FLASHING	GREEN
6	TAIL LAMPS	BROWN

Schematic — Electrical

Electrical Harness AG Plug to RV Socket (JAP3223)

- A. CONNECTOR: 7 F-TERMINAL PLUG CONFORMING TO SAE J560
- B. TAIL LIGHT CONVERTER: POLLAK 12-752
- C. CONNECTOR: 7 M-TERMINAL SOCKET, RV BLADE STYLE
- D. CABLE: 2-WIRE 12AWG, (WHITE, BLACK)

TAIL LIGHT CONVERTER		
WIRE	DESCRIPTION	COLOR
1	LEFT TURN/FLASHING	YELLOW
2	STOP LAMPS	RED
3	RIGHT TURN/FLASHING	GREEN
4	LEFT TURN/STOP	YELLOW
5	RIGHT TURN/STOP	GREEN

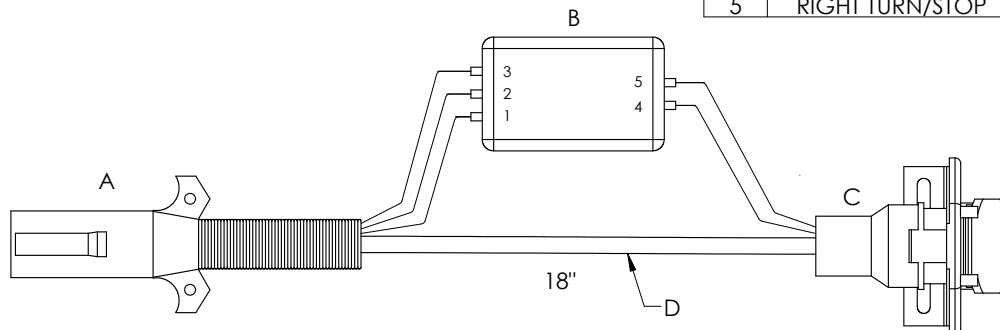

7 F-TERMINAL SAE J560 PLUG		
PIN #	DESCRIPTION	WIRE COLOR
1	GROUND	WHITE
2	CLEARANCE/MARKER	BLACK
3	LEFT TURN/FLASHING	YELLOW
4	STOP LAMPS	RED
5	RIGHT TURN/FLASHING	GREEN
6	TAIL LAMPS	BROWN
7		

7 M-TERMINAL RV BLADE SOCKET		
PIN #	DESCRIPTION	WIRE COLOR
1	GROUND	WHITE
2		
3	TAIL/RUNNING LIGHTS	BROWN
4	+12V SWITCHED PWR	BLACK
5	LEFT TURN/STOP	YELLOW
6	RIGHT TURN/STOP	GREEN
7		

Wheel, Hub and Spindle Disassembly and Assembly

WARNING

- **TIPPING OR MOVEMENT OF THE MACHINE CAN CAUSE SERIOUS INJURY OR DEATH. BE SURE MACHINE IS SECURELY BLOCKED.**
- **FALLING OBJECTS CAN CAUSE SERIOUS INJURY OR DEATH. DO NOT WORK UNDER THE MACHINE AT ANY TIME WHILE BEING HOISTED. BE SURE ALL LIFTING DEVICES AND SUPPORTS ARE RATED FOR THE LOADS BEING HOISTED. THESE ASSEMBLY INSTRUCTIONS WILL REQUIRE SAFE LIFTING DEVICES UP TO 30,000 LBS. SPECIFIC LOAD RATINGS FOR INDIVIDUAL LOADS WILL BE GIVEN AT THE APPROPRIATE TIME IN THE INSTRUCTIONS.**
- **EYE PROTECTION AND OTHER APPROPRIATE PERSONAL PROTECTIVE EQUIPMENT MUST BE WORN WHILE SERVICING IMPLEMENT.**
- **KEEP HANDS CLEAR OF PINCH POINT AREAS.**

CAUTION

- **IMPROPERLY TORQUED WHEEL NUTS/BOLTS CAN CAUSE A LOSS OF IMPLEMENT CONTROL AND MACHINE DAMAGE. TORQUE WHEEL NUTS/BOLTS TO VALUES IN TABLE. CHECK TORQUE BEFORE USE, AFTER ONE HOUR OF UNLOADED USE OR AFTER FIRST LOAD, AND EACH LOAD UNTIL WHEEL NUTS/BOLTS MAINTAIN TORQUE VALUE. CHECK TORQUE EVERY 10 HOURS OF USE THERE-AFTER. AFTER EACH WHEEL REMOVAL START TORQUE PROCESS FROM BEGINNING. WARRANTY DOES NOT COVER FAILURES CAUSED BY IMPROPERLY TORQUED WHEEL NUTS/BOLTS.**

IMPORTANT

- *Remove only one wheel and tire from a side at any given time in the following procedure.*
1. Hitch implement to tractor. Park on a firm, level surface. Set the tractor's parking brake, shut off engine and remove key.
 2. Use a safe lifting device rated at 30,000 lbs. to support the weight of your implement. Place the safe lifting device under the axle closest to the tire.
 3. Use a 300 lbs. safe lifting device to support the wheel and tire during removal.
 4. If only removing wheel and tire, skip to Step 8; otherwise continue with Step 4.



Remove the hardware retaining the hubcap. Next, remove the hubcap, gasket, cotter pin, castle nut and spindle washer. Remove hub with bearings from old spindle using a 200 lbs. lifting device.

Wheel, Hub and Spindle Disassembly and Assembly (continued)

5. Inspect the spindle and replace if necessary. If spindle does not need to be replaced, skip to Step 6; otherwise continue with Step 5.

Remove the bolt and lock nut that retain the spindle to the axle. Using a lifting device rated for 200 lbs., remove the old spindle. Coat spindle shaft with anti-seize lubricant prior to installation. Reuse bolt and lock nut to retain spindle to axle. Torque as outlined in Maintenance Section.

6. Remove seal and inspect bearings, spindle washer, castle nut and cotter pin. Replace if necessary. Pack both bearings with Extreme Pressure NLGI #2 grease and reinstall inner bearing. Install new seal in hub with garter spring facing inward to the hub by tapping on flat plate that completely covers seal while driving it square to hub. Install until flush with back face of hub. Using a 200 lb. rated lifting device, install hub assembly onto spindle. Install outer bearing, spindle washer and castle nut.

IMPORTANT

- *Do not use an impact wrench!*

7. Slowly tighten castle/slotted nut while spinning the hub until hub stops rotating. Turn castle nut counterclockwise until the hole in the spindle aligns with the next notch in castle nut. Hub should spin smoothly with minimal drag and no end play. If play exists, tighten to next notch of castle nut. If drag exists, then back castle nut to next notch. Spin and check again. Install cotter pin. Clean face for hub cap gasket and install gasket, grease-filled hub cap and retain hubcap with hardware removed. Tighten hubcap hardware in alternating pattern.
8. Attach the wheel(s) and tire(s) to the hub using the same rated safe lifting device for removal. Tighten wheel nuts to appropriate requirements and recheck as outlined in the Wheels and Tires section of this manual.
9. Raise implement, remove lifting device and lower tire to the ground.

Wheels and Tires

Wheel Nut Torque Requirements

CAUTION

- **IMPROPERLY TORQUED WHEEL NUTS/BOLTS CAN CAUSE A LOSS OF IMPLEMENT CONTROL AND MACHINE DAMAGE. TORQUE WHEEL NUTS/BOLTS TO VALUES IN TABLE. CHECK TORQUE BEFORE USE, AFTER ONE HOUR OF UNLOADED USE OR AFTER FIRST LOAD, AND EACH LOAD UNTIL WHEEL NUTS/BOLTS MAINTAIN TORQUE VALUE. CHECK TORQUE EVERY 10 HOURS OF USE THEREAFTER. AFTER EACH WHEEL REMOVAL START TORQUE PROCESS FROM BEGINNING. WARRANTY DOES NOT COVER FAILURES CAUSED BY IMPROPERLY TORQUED WHEEL NUTS/BOLTS.**

Failure to check torque before first load may damage wheel nut/bolt seats. Once seats are damaged, it will become impossible to keep nuts/bolts tight. Tighten nuts/bolts to applicable torque value shown in table. Start all nuts/bolts by hand to prevent cross threading. Torque nuts/bolts in the recommended sequence as shown in Diagram 1.

WHEEL HARDWARE	
SIZE	FOOT-POUNDS
5/8"-18(UNF) Grade 5	165 Ft.-Lbs.
5/8"-18(UNF) Grade 8	175 Ft.-Lbs.

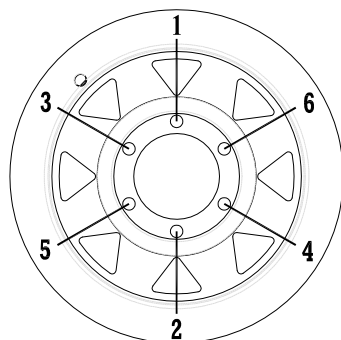

6 Bolt

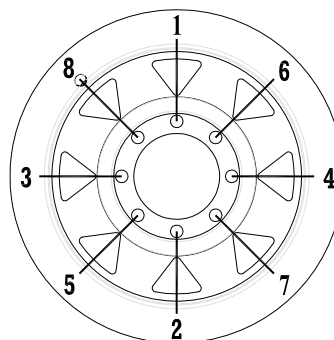

8 Bolt

DIAGRAM 1

Wheels and Tires (continued)

Tire Pressure

The following is to be used as a general guide for tire inflation and figures can vary depending on specific brand of tire used. It is important that tires are inspected after unit is loaded. The tire should stand up with no side-wall buckling or distress as tire rolls. Record the pressure needed to support the full load and maintain this pressure to achieve proper tire life. Do not exceed maximum recommended tire pressure.

Tire Pressure for Renegade Anhydrous Applicators				
Tire Make	Part #	Tire Size	Load Index / Ply	Max PSI
			Rating	
Carlisle	99136	20.5x8.0B10	F-Ply	35
	99311	11L15 I-1	F-Ply	90
Firestone	9502097	VF385/65R22.5 I-1	163D	70
	9502085	VF295/75R22.5 I-1	151D	64
	91289	7.60x15 I-1	8-Ply	52
Goodyear	9503244	12.4R38 R-1	14-Ply	56
Mitas	9503228	380/85R34 R-1W	146A8	44
Titan	9503246	7.50-15 HF-1	6-Ply	45
	94557	27-9.50x15 HF-1	6-ply	45

(All tire pressures in psi)

Tire Warranty

For questions regarding new tire warranty, please contact your local original equipment tire dealer. Used tires carry no warranty. Following are phone numbers and Websites for your convenience:

Firestone www.firestoneag.com
Phone 800-847-3364

Continental/Mitas www.mitas-tires.com
Phone 704-542-3422
Fax 704-542-3474

Titan www.titan-intl.com
or Phone 800-USA-BEAR
Goodyear Fax 515-265-9301

Carlisle/Ironman www.carlisletire.com
Phone 800-260-7959
Fax 800-352-0075

Complete Torque Chart

Capscrews - Grade 5

NOTE:

- Grade 5 capscrews can be identified by three radial dashes on the head.
- For wheel torque requirements, refer to Wheels and Tires.
- Tighten U-bolts evenly and equally to have the same number of threads exposed on each end.

SIZE	FOOT POUNDS	NEWTON METERS
1/4-20 1/4-28	8-10 9-11	11-13 12-15
5/16-18 5/16-24	15-17 17-19	20-23 23-26
3/8-16 3/8-24	25-28 28-31	34-38 38-42
7/16-14 7/16-20	40-45 45-50	54-61 61-68
1/2-13 1/2-20	62-68 68-75	84-92 92-102
9/16-12 9/16-18	90-98 100-110	122-133 134-148
5/8-11 5/8-18	120-135 124-137	162-183 168-186
3/4-10 3/4-16	200-220 210-230	270-300 285-310
7/8-9 7/8-14	330-350 360-380	425-475 460-515
1-8 1-14	500-525 540-560	675-710 730-760
1 1/8-7 1 1/8-12	600-635 665-700	815-860 920-950
1 1/4-7 1 1/4-12	850-895 940-990	1150-1215 1275-1340
1 3/8-6 1 3/8-12	1125-1175 1280-1335	1525-1590 1735-1810
1 1/2-6 1 1/2-12	1500-1560 1685-1755	2035-2115 2285-2380

IMPORTANT

- Follow these torque recommendations except when specified in text.

Complete Torque Chart

Cap screws - Grade 8

NOTE:

- Grade 8 cap screws can be identified by six radial dashes on the head.
- For wheel torque requirements, refer to Wheels and Tires.
- Tighten U-bolts evenly and equally to have the same number of threads exposed on each end.



SIZE	FOOT POUNDS	NEWTON METERS
5/16-18	20-22	27-30
5/16-24	21-23	28-31
3/8-16	35-39	47-53
3/8-24	36-41	49-55
7/16-14	54-58	73-78
7/16-20	55-60	75-80
1/2-13	82-88	110-120
1/2-20	94-99	125-135
9/16-12	127-134	170-180
9/16-18	147-155	199-210
5/8-11	160-170	215-230
5/8-18	165-175	225-235
3/4-10	280-295	380-400
3/4-16	330-365	445-495
7/8-9	410-430	555-580
7/8-14	420-440	570-595
1-8	630-650	850-880
1-14	680-700	920-950
1 1/8-7	900-930	1220-1260
1 1/8-12	930-950	1260-1290
1 1/4-7	1250-1300	1695-1760
1 1/4-12	1280-1320	1735-1790

IMPORTANT

- Follow these torque recommendations except when specified in text.

Hydraulic Fittings - Torque and Installation

SAE Flare Connection (J. I. C.)

1. Tighten nut with finger until it bottoms the seat.
2. Using a wrench, rotate nut to tighten. Turn nut 1/3 turn to apply proper torque.

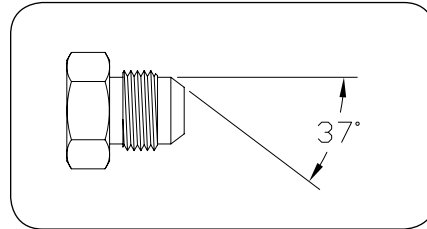

SAE Straight Thread O-Ring Seal

1. Back off jam nut and washer to expose smooth surface for O-ring seal.
2. Lubricate o-ring.
3. Thread into port until washer bottoms onto spot face.
4. Position elbows by backing up adapter.
5. Tighten jam nut.

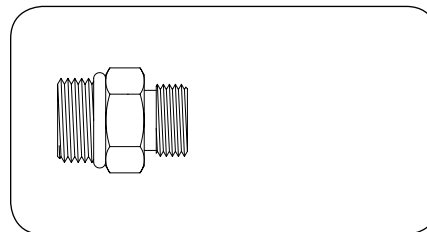

NH3 Fittings - Torque and Installation

NPT - NPTF Threads

The proper method of assembling pipe threaded connectors is to assemble them finger tight and then wrench tighten further to the specified number of turns from finger tight (T.F.F.T.) given in the table below. The assembly procedure given below is recommended to minimize the risk of leakage and/or damage to components.

1. Inspect port and connectors to ensure that threads on both are free of dirt, burrs and excessive nicks.
2. Apply thread sealant approved for anhydrous ammonia to male pipe threads. The first one to two threads should be left uncovered to avoid system contamination. If PTFE tape is used, it should be wrapped 1 ½ -2 turns in clockwise direction when viewed from the pipe thread end.

CAUTION

- MORE THAN TWO TURNS OF TAPE MAY CAUSE DISTORTION OR CRACKING OF THE PORT.

3. Screw the connector into the port to the finger tight position.
4. Wrench tighten the connector to the appropriate turns from finger tight (T.F.F.T) values shown in the table, making sure that the tube end of a shaped connector is aligned to receive the incoming tube or hose assembly.

IMPORTANT

- Never back off (loosen) pipe threaded connectors to achieve alignment.
5. If leakage persists after following the above steps, check for damaged threads and total number of threads engaged.

Thread Size NPTF	Inches Millimeter	Threads Per Inch	Pitch	D	G	Assembly Turns (Steel)
						T.F.F.T.
1/8"	$\frac{\text{in}}{\text{mm}}$	27	$\frac{0.037}{0.94}$	$\frac{0.40}{10.24}$	$\frac{0.16}{4.1}$	2 - 3
1/4"	$\frac{\text{in}}{\text{mm}}$	18	$\frac{0.056}{1.41}$	$\frac{0.54}{13.61}$	$\frac{0.23}{5.8}$	2 - 3
3/8"	$\frac{\text{in}}{\text{mm}}$	18	$\frac{0.056}{1.41}$	$\frac{0.67}{17.05}$	$\frac{0.24}{6.1}$	2 - 3
1/2"	$\frac{\text{in}}{\text{mm}}$	14	$\frac{0.071}{1.81}$	$\frac{0.84}{21.22}$	$\frac{0.32}{8.1}$	2 - 3
3/4"	$\frac{\text{in}}{\text{mm}}$	14	$\frac{0.071}{1.81}$	$\frac{1.05}{26.56}$	$\frac{0.34}{8.6}$	1.5 - 2.5
1 1/4"	$\frac{\text{in}}{\text{mm}}$	11 1/2	$\frac{0.087}{2.21}$	$\frac{1.33}{33.78}$	$\frac{0.42}{10.7}$	1.5 - 2.5
1 1/2"	$\frac{\text{in}}{\text{mm}}$	11 1/2	$\frac{0.087}{2.21}$	$\frac{1.89}{48.05}$	$\frac{0.42}{10.7}$	1.5 - 2.5

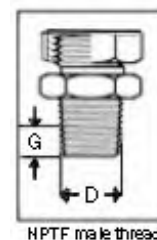

Notes

SECTION V

Parts

Clean Water Tank Components.....	5-2	Torsion Arm Basket (Short Arms) Components.....	5-58
Hitch, Transport Chain, Manual Holder and Jack.....	5-4	Torsion Arm/Rigid Basket Mounting Brackets.....	5-59
Depth Control Components.....	5-6	Basket Flat Mount with Hardware.....	5-60
Main Frame Components.....	5-8	Residue Manager Blade Mounting Assembly.....	5-61
Primary Wing Components.....	5-10	StripTill Residue Manager Components.....	5-62
Secondary 5'8" Wing Components.....	5-12	SuperShooter Hitch Assembly Components.....	5-64
Secondary 3'2" Wing Components.....	5-14	SuperShooter Hitch, Low Mounting Components.....	5-66
Secondary Wing Extension to 50 Ft.....	5-16	Auto-Lok SuperShooter Hitch Components.....	5-67
Straight Extension Kit.....	5-18	SuperShooter III Connection	
Pin Adjust Gauge Wheel Leg Assembly.....	5-19	Single 1.25" Plumbing.....	5-68
Dual Wheel Lift with 385/65R22.5 Tires.....	5-20	SuperShooter III Connection	
Dual Wheel Lift with 295/75R22.5 Tires.....	5-22	Double 1.25" Plumbing.....	5-70
Single Wheel Lift Components.....	5-24	SuperShooter III Components - 1.25" Connection....	5-72
Hub and Spindle Components.....	5-26	SuperShooter III Single 1 1/4" Assembly.....	5-74
Hub and Spindle Components.....	5-27	SuperShooter III Max Single 1 1/2" Assembly.....	5-75
Hub and Spindle Components.....	5-28	SuperShooter III Connection	
Decals.....	5-29	Single 1.5" Plumbing.....	5-76
Main Frame to Primary Wing Hydraulics.....	5-30	SuperShooter III Connection	
Main Frame Transport Wheel		Double 1.5" Plumbing.....	5-78
& Depth Control Hydraulics.....	5-32	SuperShooter III Components - 1.5" Connection.....	5-80
Wing Gauge Wheel Hydraulics.....	5-34	Impellicone and Mounting Hardware	
Primary Wing to Secondary Wing Hydraulics.....	5-35	2 Sec John Blue.....	5-82
Secondary Wing Extension Hydraulics		3 Sec John Blue.....	5-84
(52' Units ONLY).....	5-36	4 Sec John Blue.....	5-86
Coulter Mounting Bracket Components.....	5-37	Manifold and Mounting Hardware	
Offset Stagger Bracket & Bracket Extension.....	5-38	2 Sec Continental.....	5-88
Super 1200 Flex Coulter Hub Assembly Components.....	5-40	3 Sec Continental.....	5-90
Super 1200 Flex Coulter & Post Assembly.....	5-40	4 Sec Continental.....	5-92
Super 1200 Flex Coulter Assembly Components.....	5-41	Distribution 2-Section Hoses and Electrical.....	5-94
SealPro II & Blades.....	5-42	Distribution 3-Section Hoses and Electrical.....	5-96
DiscCover Sealer.....	5-44	Distribution 4-Section Hoses and Electrical.....	5-98
Disc Sealer Spring Add-On Kit Optional.....	5-46	1.5" Flow Control Valve.....	5-100
Sealer Hanger with Blade Mounting.....	5-47	1.0" Flow Control Valve (Optional).....	5-102
Row Clamp w/EdgeBent Shank & Coulter Mount.....	5-48	Cooler - Vortex.....	5-104
Shank Assembly 1 1/4" EdgeBent SCS Less Coulter.....	5-50	Cooler - Continental.....	5-106
Row Clamp, 1 1/4" EdgeBent MaxPac.....	5-52	ISOBUS Rate Controller.....	5-108
MaxPac Basket Mount Arm Components.....	5-53	Raven 450 Rate Controller Option.....	5-109
MaxPac Mount with EdgeBent Shank Bundle.....	5-54	Lighting Components.....	5-110
Coulter Bracket Extension 9 7/8" Kit.....	5-56		
Coulter Bracket Extension 16 7/8" Kit.....	5-57		

Clean Water Tank Components

Please visit www.unverferth.com/parts/ for the most current parts listing.

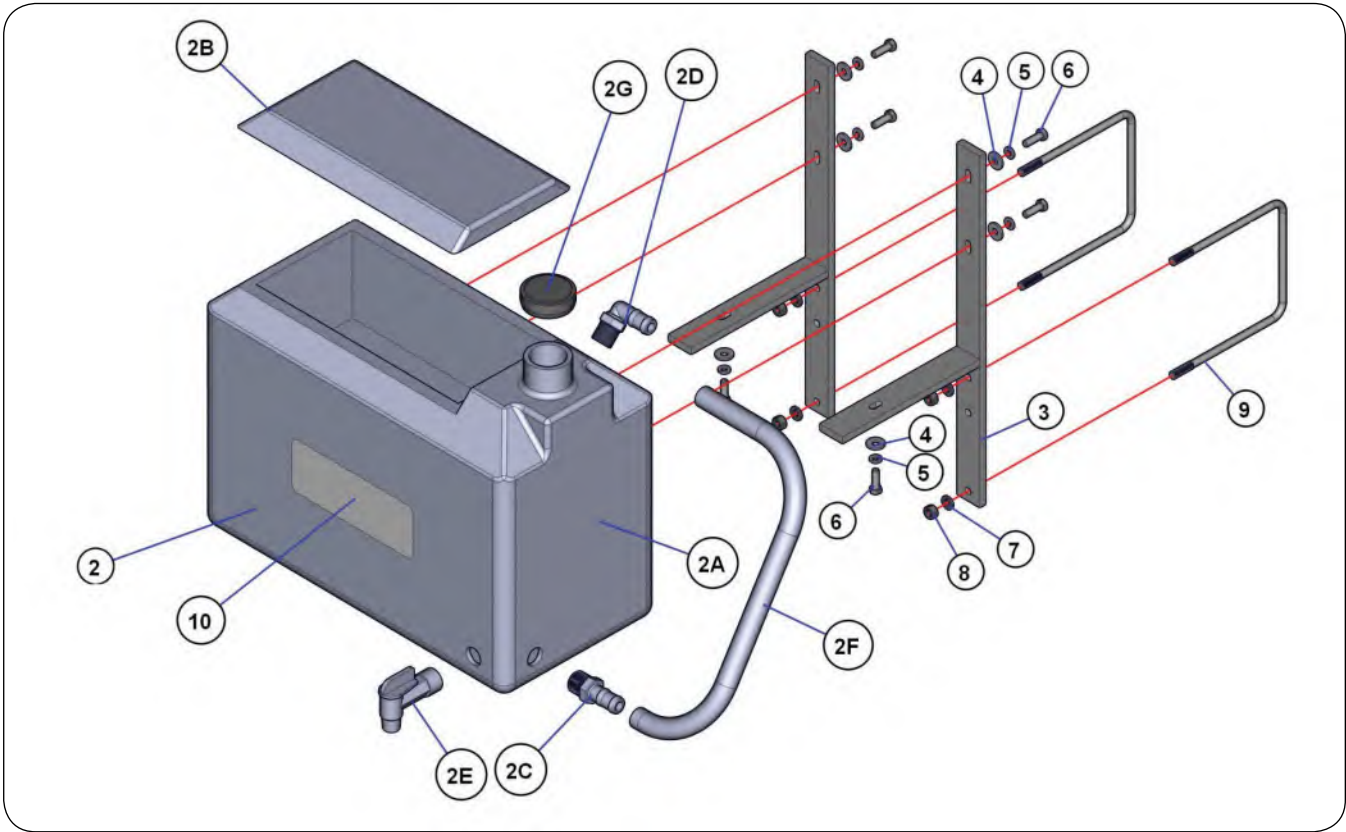

Clean Water Tank Components

Please visit www.unverferth.com/parts/ for the most current parts listing.

ITEM	PART NUMBER	DESCRIPTION	QTY	NOTES
	JAAM2427	Clean Water Tank & Toolbox		INCLUDES ITEMS 1-10
1	JPKG00040	9 Gallon Clean Water Tank Package	1	Includes Items 2-8
2	JAP2137	Clean Water Tank Assembly	1	Includes Items 2A-2G
2A	-	Tank	1	
2B	-	Toolbox Lid	1	
2C	TA814861	Hose Barb, 3/4"-14MPT x 3/4" HS Straight Poly Hose Barb (HB075)	1	
2D	TA814961	90° Elbow, 3/4"-14MPT x 3/4" Poly Hose Barb	1	
2E	JAP2329	Spigot	1	
2F	TA806558	3/4" Clear Vinyl Tubing - 24" Length	2 Ft.	
2G	JAP2272	2" Fill Cap Replacement	1	
3	JAM2136	9 Gallon Tank Mounting Bracket	2	
4	9405-068	Flat Washer, 5/16" SAE	6	
5	9404-019	Lock Washer, 5/16"	6	
6	9390-030	Capscrew, 5/16"-18UNC x 1" G5	6	
7	9404-021	Lock Washer, 3/8"	4	
8	9394-006	Hex Nut, 3/8"-16UNC	4	
9	JBP3351	U-Bolt, 3/8"-16UNC x 7", 6 7/16CC	2	
10	JAP2215	Decal, BLU-JET, 3" x 8"	1	

Hitch, Transport Chain, Manual Holder and Jack Components

Please visit www.unverferth.com/parts/ for the most current parts listing.

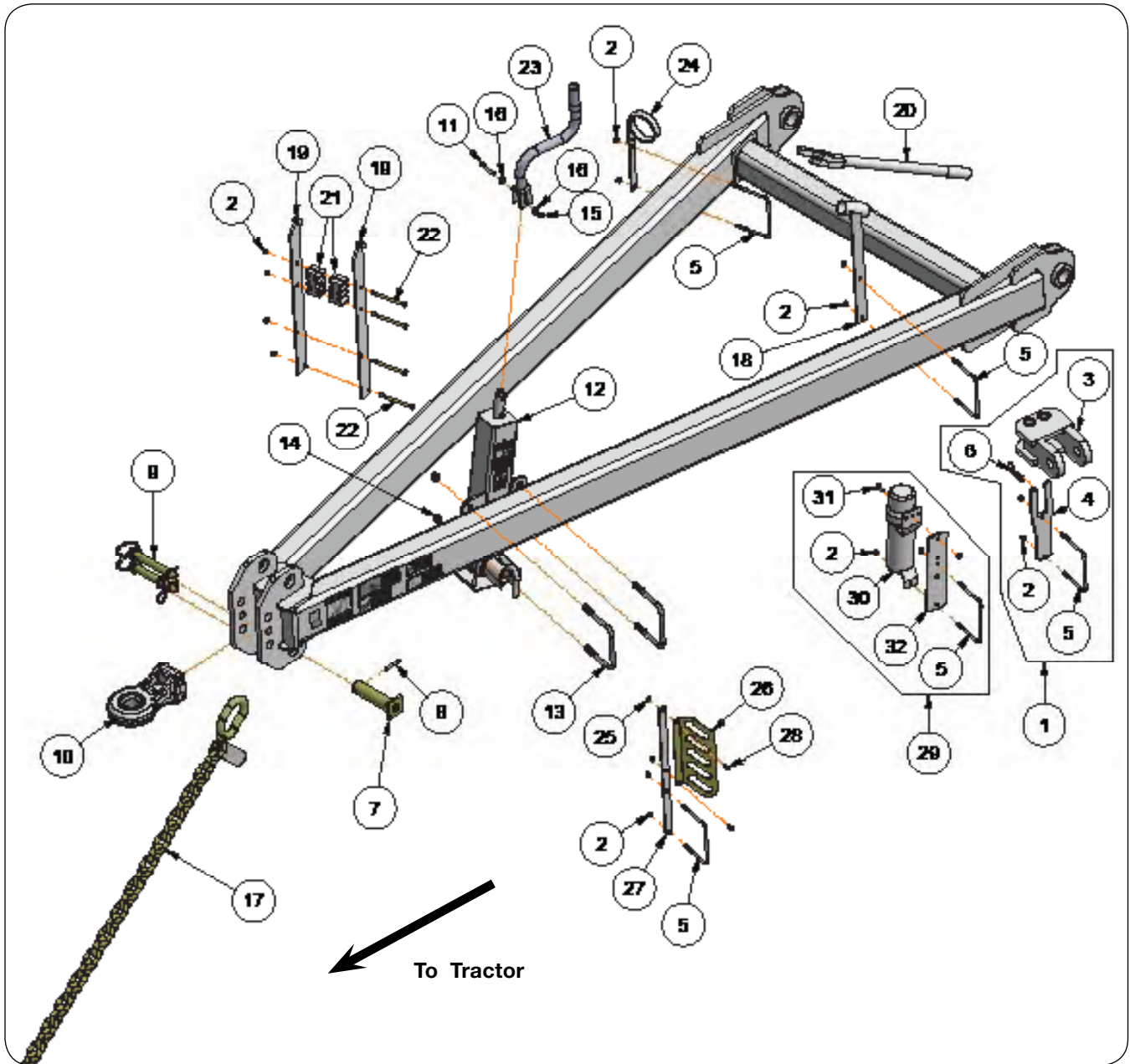

Hitch, Transport Chain, Manual Holder and Jack Components

Please visit www.unverferth.com/parts/ for the most current parts listing.

ITEM	PART NUMBER	DESCRIPTION	QTY	NOTES
1	45581B	Clevis Hitch Assembly	1	Includes Items 2-6
2	9928	Lock Nut/Top, 3/8"-16UNC	15	
3	JAM2144	Clevis Hitch	1	
4	JAM2145	Hitch Storage Bracket Mount	1	
5	JBP3045	U-Bolt, 3/8"-16UNC x 5", 6 7/16"CC	6	
6	JBP3500	Hair Clip Pin, 3/16"	1	
7	JBM3610	Pin Weldment, 1 3/4" Dia. x 6 5/16"	1	
8	9392-182	Roll Pin, 3/8" Dia. x 2 1/2"	1	
9	95109	Hitch Pin 1" Dia. x 7" w/Hairpin	2	
10	JAP3232	Ball Swivel Hitch, CAT4	1	
11	9390-061	Capscrew, 3/8"-16UNC x 2 1/2" G5	1	
12	JAM2549	Jack, 12 Ton	1	
13	JBP3099	U-Bolt, 5/8"-11UNC x 6 x 6	2	
14	9801	Lock Nut/Top, 5/8"-11UNC	4	
15	902875	Lock Nut/Center, 3/8"-16UNC	1	
16	9405-076	Flat Washer, 3/8" USS	2	
17	9003269	Transport Chain (60,600#)	1	
18	JAM2197	Wrench Storage Bracket Weldment	1	
19	JAM4528	Hose Holder Bracket Weldment	2	
20	JAM4759	Turnbuckle Wrench Weldment	1	
21	JAP2871	Hose Retainer	2	
22	9390-069	Capscrew, 3/8"-16UNC x 5" G5	4	
23	JAP3234	Crank Handle	1	
24	JAM4015	Hose Retainer Closed Loop	2	
25	9807	Lock Nut/Top, 5/16"-18UNC	2	
26	415536	Hose Caddy	1	
27	46618B	Hose Caddy Mounting Plate	1	
28	9390-028	Capscrew, 5/16"-18UNC x 3/4" G5	2	
29	JAAM2639	Manual Holder Assembly	1	Includes Items 2, 5, 30-32
30	900552	Manual Holder	1	
31	9390-055	Capscrew, 3/8"-16UNC x 1" G5	1	
32	JAM7640	Manual Mounting Bracket	1	

Depth Control Components

Please visit www.unverferth.com/parts/ for the most current parts listing.

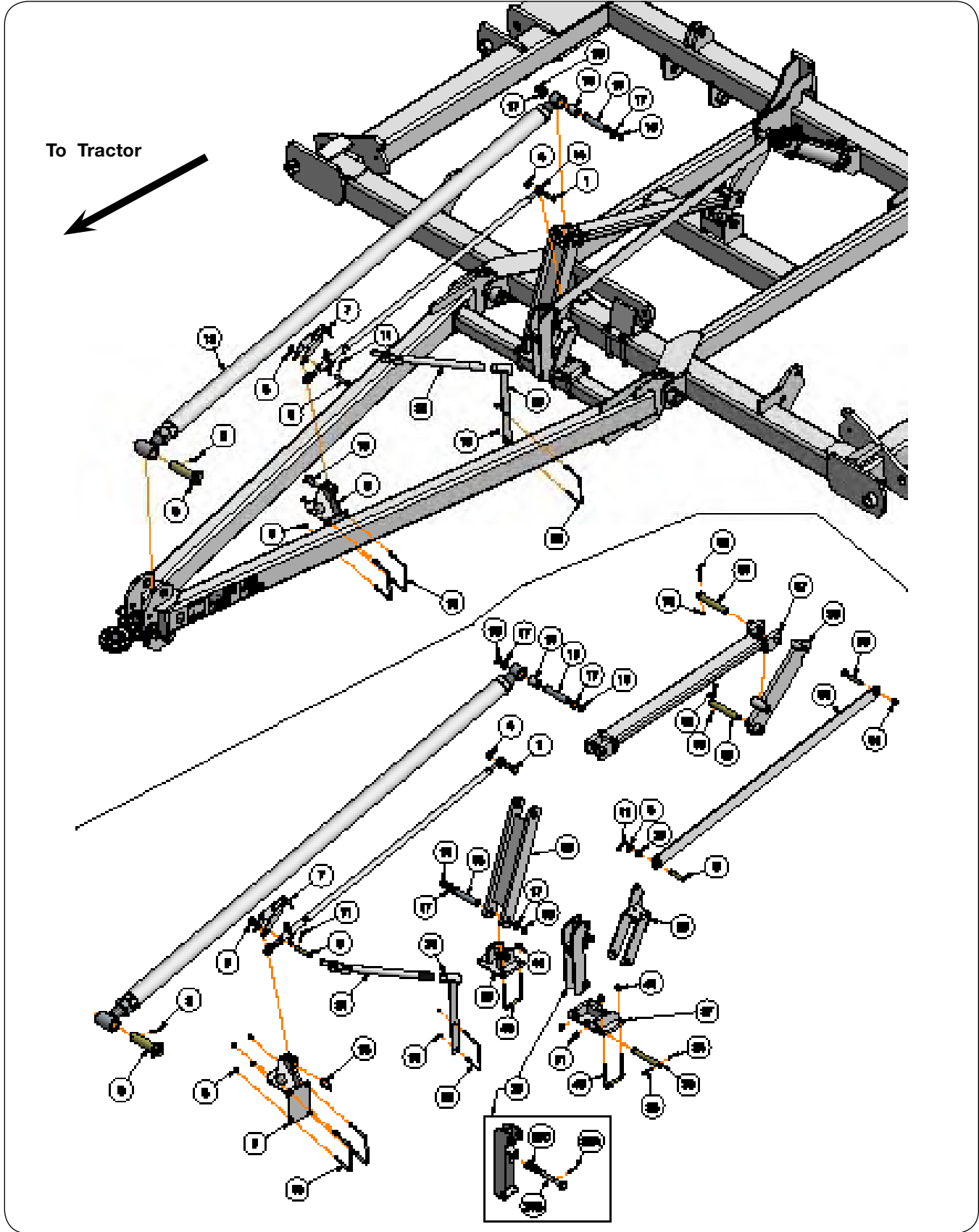

Depth Control Components

Please visit www.unverferth.com/parts/ for the most current parts listing.

ITEM	PART NUMBER	DESCRIPTION	QTY	NOTES
1	9390-145	Capscrew, 3/4"-10UNC x 2" G5	1	
2	9392-182	Roll Pin, 3/8" Dia. x 2 1/2"	2	
3	9405-104	Flat Washer, 3/4" SAE	2	
4	96732	Lock Nut/Center, 3/4"-10UNC	1	
5	9800	Lock Nut/Top, 1/2"-13UNC	4	
6	9981	Clevis Pin, 3/4" Dia. x 3 1/2"	2	
7	JAM6271	Adjuster Latch Plate	1	
8	JAM6276	Adjuster Bracket Weldment w/Decal	1	
	JAP2481	Decal, Transport Lock	1	
9	JBM3610	Pin Weldment, 1 3/4" Dia. x 6 5/16"	2	
10	JBP3330	U-Bolt, 1/2"-13UNC X 5 1/8", 6 9/16"CC	2	
11	JBP3504	Hair Clip Pin, 1/8"	2	
12	JAAM4768	Turnbuckle Assembly	1	
	JAM7239	Turnbuckle Screw, RH w/ 4" Oval Tube	-	
	JAM7240	Turnbuckle Screw, LH w/ 2 1/8" Oval Tube	-	
13	JBP3376	Wire Retaining Pin, 1/4"Dia. x 2"	1	
14	JAAM2930	Adjustment Linkage	1	
15	JBM3547	Pin, 1 1/4" Dia. x 5 3/4"	2	
16	JAP2711	Snap Ring 1 1/4", External Heavy-Duty Retaining Ring	8	
17	91174	Machinery Bushing, 1 7/8" OD x 1 1/4" ID x 14GA	8	
18	9928	Lock Nut/Top, 3/8"-16UNC	8	
19	JEM3735	Bushing, 1 3/4" OD x 1.274" ID x 2 1/8"	1	
20	JAM2197	Wrench Storage Bracket Weldment	1	
21	JAM4759	Turnbuckle Wrench	1	
22	JBP3045	U-Bolt, 3/8"-16UNC x 5", 6 7/16"CC	1	
23	9390-059	Capscrew, 3/8"-16UNC x 2" G5	3	
24	9398-012	Elastic Lock Nut, 3/8"-16UNC	1	
25	JAAM2928	Stop Arm With Plunger Assembly	1	Includes Items 25A, 25B, 25C
25A	9392-180	Roll Pin, 3/8" Dia. x 2"	1	
25B	JAM4627	Depth Gauge Plunger	1	
25C	JAP2193	Compression Spring 1.4" OD x 3"	1	
26	JAM4511	Turnbuckle Support Bracket Weldment	1	
27	JAM6263	Pivot Bracket Weldment	1	
28	JAM6264	Valve Arm Weldment	1	
29	JBM3453	Spacer, 1 1/4" OD x .812" ID x 13/16"	1	
30	JBM3487	Pin, 1" Dia. x 7 3/4"	1	
31	JBP3215	Machinery Bushing, 1 1/2" OD x 1" ID x 14GA	2	
32	9390-061	Capscrew, 3/8"-16UNC x 2 1/2" G5	3	
33	9390-154	Capscrew, 3/4"-10UNC x 4 1/2" G5	1	
34	96732	Lock Nut/Center, 3/4"-10UNC	1	
35	JAM4512	Turnbuckle Support Weldment	1	
36	JAM6182	Tongue Cylinder Arm Linkage	1	
37	JAM6183	Tongue Cylinder Linkage	1	
38	JAM6266	Stop Linkage	1	
39	JBM3465	Pin, 1 1/4" Dia. x 7 3/4"	2	
40	JBP3347	U-Bolt, 5/8"-11UNC x 4 x 5 5/8"	4	
41	9801	Lock Nut/Top, 5/8"-11UNC	8	

Main Frame Components

Please visit www.unverferth.com/parts/ for the most current parts listing.

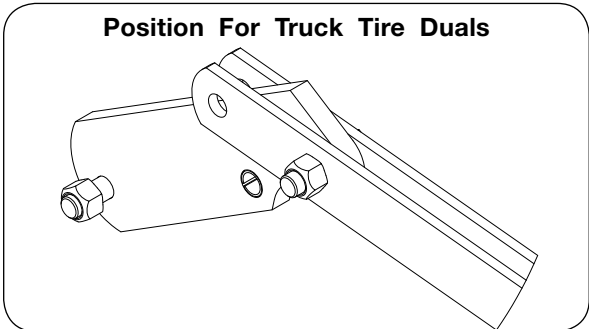
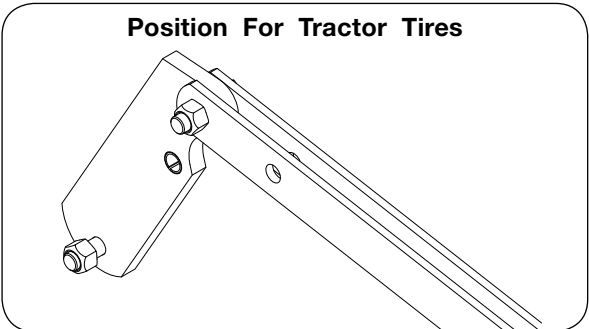
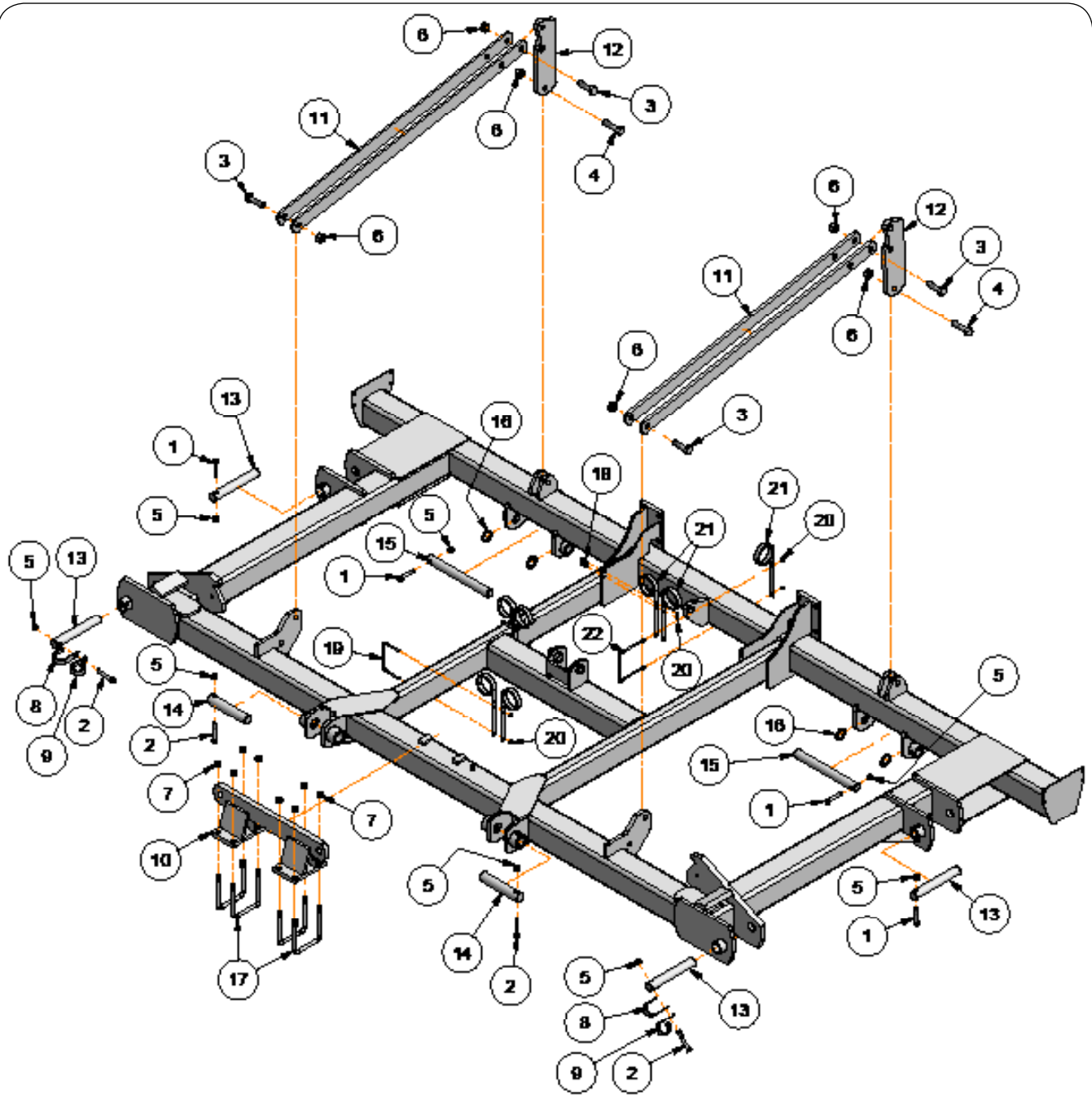

Main Frame Components

Please visit www.unverferth.com/parts/ for the most current parts listing.

ITEM	PART NUMBER	DESCRIPTION	QTY	NOTES
1	9390-130	Capscrew, 5/8"-11UNC x 3 1/2" G5	6	
2	9390-132	Capscrew, 5/8"-11UNC x 4" G5	4	
3	9390-189	Capscrew, 1"-8UNC x 3 1/2" G5	4	
4	9390-191	Capscrew, 1"-8UNC x 4" G5	6	
5	9398-019	Elastic Lock Nut, 5/8"-11UNC	10	
6	9663	Lock Nut/Top, 1"-8UNC	6	
7	9802	Lock Nut/Top, 3/4"-10UNC	8	
8	JAM4415	Hose Retainer Open Loop	2	
9	JAM4442	Hose Retainer Closed Loop	2	
10	JAM4563	Bolt-On Cylinder Lug	1	
11	JAM6179	Cylinder Lug Support Linkage	4	
12	JAM6202	Bolt-On Cylinder Lug w/Notch	2	
13	JBM3485	Pin, 1 3/4" Dia. x 12 1/8"	4	
14	JBM3565	Pin, 2" Dia. x 10 1/4"	2	
15	JBM3664	Pin, 1 3/4" Dia. x 16 9/16"	2	
16	JBP3205	Machinery Bushing 2 1/2" OD x 1 3/4" ID x 10GA	8	
17	JBP3350	U-Bolt, 3/4"-10UNC x 7 11/16", 6 13/16CC	4	
18	9390-057	Capscrew, 3/8"-16UNC x 1 1/2" G5	8	
19	95142	U-Bolt, 3/8"-16UNC x 4", 6 7/16CC	4	
20	9928	Lock Nut/Top, 3/8"-16UNC	50	
21	JAM4015	Hose Retainer Closed Loop 6" & 7" Mounting	28	
22	JBP3351	U-Bolt, 3/8"-16UNC x 7", 6 7/16CC	17	

Primary Wing Components

Please visit www.unverferth.com/parts/ for the most current parts listing.

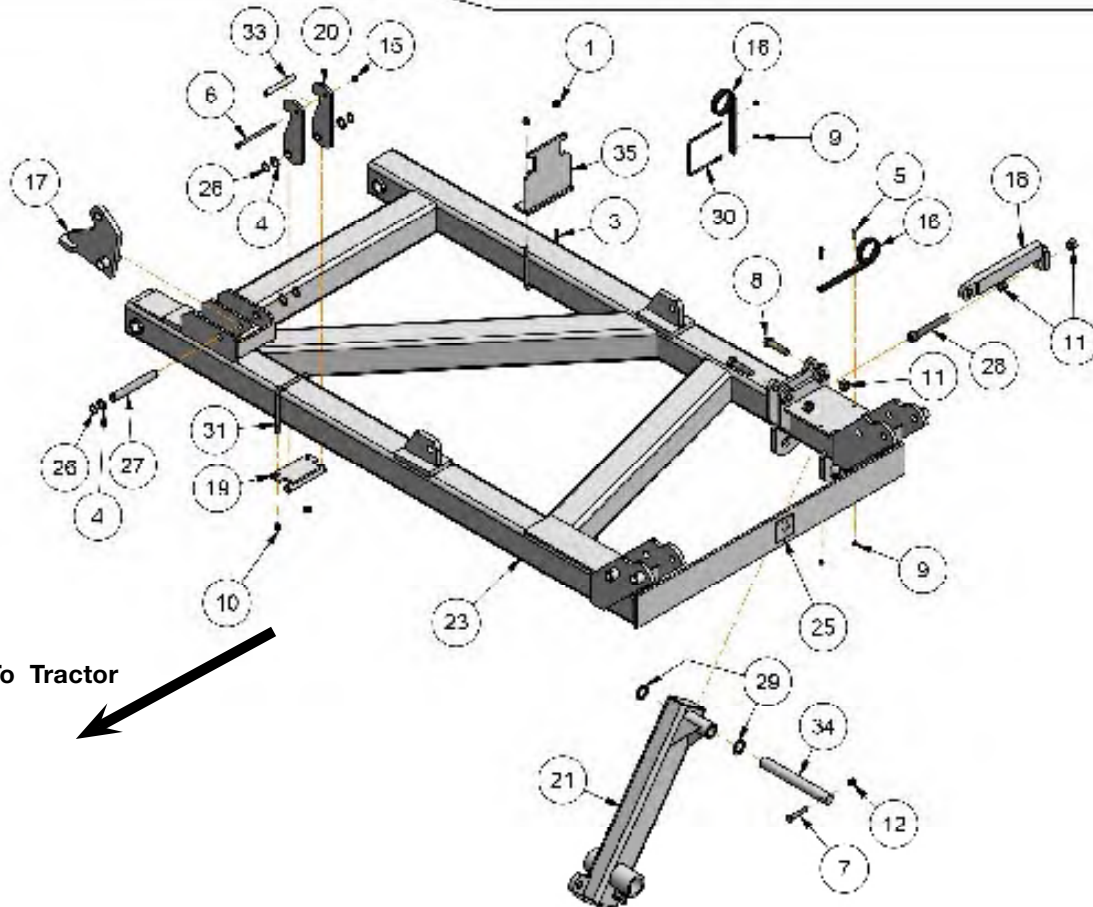
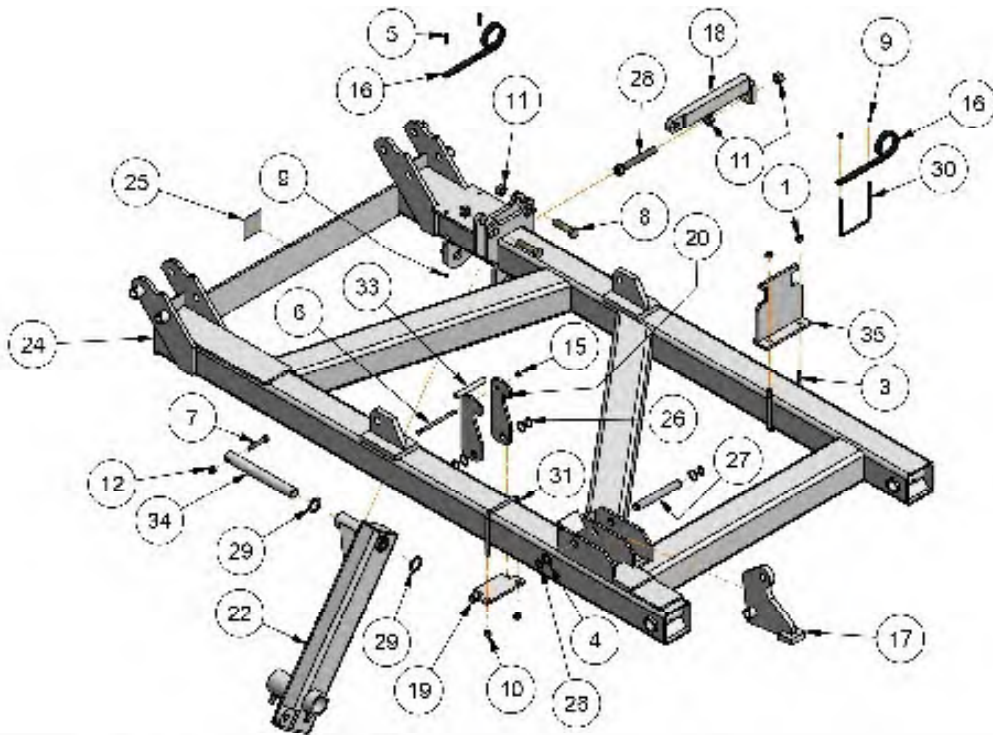

Primary Wing Components

Please visit www.unverferth.com/parts/ for the most current parts listing.

ITEM	PART NUMBER	DESCRIPTION	QTY	NOTES
1	9801	Lock Nut/Top, 5/8"-11UNC	16	
2	9404-029	Lock Washer, 5/8"	16	
3	JBP3354	U-Bolt 5/8"-11UNC x 7 3/4", 6 11/16"CC	2	
4	91174	Machinery Bushing, 1 7/8" OD x 1 1/4" ID x 14GA	12	
5	9390-057	Capscrew, 3/8"-16UNC x 1 1/2" G5	6	
6	9390-119	Capscrew, 1/2"-13UNC x 8" G5	2	
7	9390-130	Capscrew, 5/8"-11UNC x 3 1/2" G5	6	
8	9390-191	Capscrew, 1"-8UNC x 4" G5	6	
9	9928	Lock Nut/Top, 3/8"-16UNC	46	
10	9801	Lock Nut/Top, 5/8"-11UNC	16	
11	92199	Lock Nut/Center, 1"-8UNC	14	
12	9398-019	Elastic Lock Nut, 5/8"-11UNC	10	
13	N/A		-	
14	N/A		-	
15	9800	Lock Nut/Top, 1/2"-13UNC	2	
16	JAM4015	Hose Retainer Closed Loop 6" & 7" Mounting	20	
17	JAM4524	Rocker Plate Weldment	2	
18	JAM4564	Cylinder Lug Weldment, Screw Adjust	2	
19	JAM4566	Secondary Wing Latch Pivot Weldment	2	
20	JAM4568	Secondary Wing Lock Plate	4	
21	JAM6163	Wheel Leg LH Weldment w/Single Loop	1	
22	JAM6164	Wheel Leg RH Weldment w/Single Loop	1	
23	JAM6187BB	Primary Wing, LH	1	
24	JAM6188BB	Primary Wing, RH	1	
25	97337	Decal, WARNING (Wings)	4	
26	JAP2711	Snap Ring 1 1/4", External Heavy-Duty Retaining Ring	12	
27	JBM3544	Pin, 1 1/4" Dia. x 9"	2	
28	JBM3555	Hex Bolt Weldment 1"-8UNC x 7 5/16"	2	
29	JBP3205	Machinery Bushing, 2 1/2" OD x 1 3/4" ID x 10GA	8	
30	JBP3351	U-Bolt, 3/8"-16UNC x 7", 6 7/16"CC	18	
31	JBP3354	U-Bolt, 5/8"-11UNC x 7 3/4", 6 11/16"CC	2	
32	N/A		-	
33	JAM4567	Spacer Pipe	2	
34	JBM3497	Pin, 1 3/4" Dia. x 14 3/4"	2	
35	JAM6181	Wing Rest and Latch Weldment	2	

Secondary 5'8" Wing Components

Please visit www.unverferth.com/parts/ for the most current parts listing.

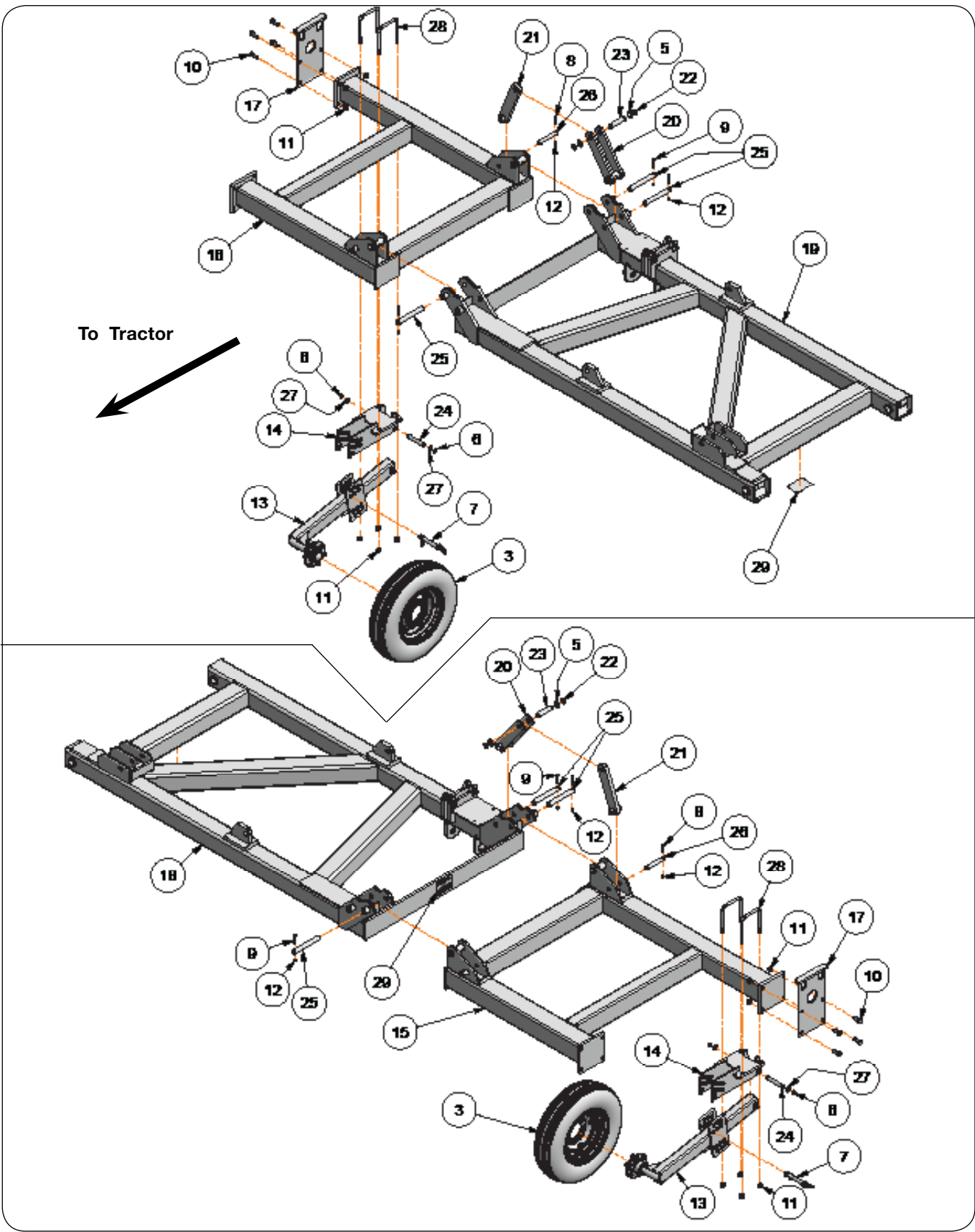

Secondary 5'8" Wing Components

Please visit www.unverferth.com/parts/ for the most current parts listing.

ITEM	PART NUMBER	DESCRIPTION	QTY	NOTES
1	81145SM	Mounted Tire & Wheel	2	Includes Items 2A, 2B, 2C
2	W615-6SM	6 x 15 Implement Wheel	1	Not Shown
3	N/A	Tire TL7.6B15 8-Ply	1	Not Shown
4	9002500	Valve Stem	1	Not Shown
5	91174	Machinery Bushing, 1 7/8" OD x 1 1/4" ID x 14GA	4	
6	91192	Retaining Ring, 1"	4	
7	93950	Hitch Pin 1" Dia. x 8" w/Hairpin	2	
8	9390-059	Capscrew, 3/8"-16UNC x 2" G5	2	
9	9390-061	Capscrew, 3/8"-16UNC x 2 1/2" G5	6	
10	9390-145	Capscrew, 3/4"-10UNC x 2" G5	8	
11	9802	Lock Nut, 3/4"-10UNC	16	
12	9398-012	Elastic Lock Nut, 3/8"-16UNC	8	
13	JAM24024	Pin Adjust Gauge Wheel Leg Assembly	2	
14	JAM24025	Pin Adjust Gauge Wheel Mounting Bracket	2	
15	JAM4551BB	Secondary Wing, LH, 5'8"	1	
16	JAM4552BB	Secondary Wing, RH, 5'8"	1	
17	JAM4565	Rest Weldment	2	
18	JAM6187BB	Primary Wing, LH	1	
19	JAM6188BB	Primary Wing, RH	1	
20	JAM6189	Secondary Wing Linkage Weldment	2	
21	JAM6197	Wing Fold Linkage Weldment	2	
22	JAP2711	Snap Ring 1 1/4", External Heavy-Duty Retaining Ring	4	
23	JBM3548	Pin, 1 1/4" Dia. x 4 3/4"	2	
24	JBM3650	Pin, 1" Dia. x 5 9/16"	2	
25	JBM3816	Pin, 1 1/4" Dia. x 9 13/16"	6	
26	JBM3817	Pin, 1" Dia. x 6 7/8"	2	
27	JBP3215	Machinery Bushing, 1 1/2" OD x 1" ID x 14GA	4	
28	JBP3350	U-Bolt, 3/4"-10UNC x 6"W x 7 11/16"L	4	
29	97337	Decal, WARNING (Wings)	4	

Secondary 3'2" Wing Components

Please visit www.unverferth.com/parts/ for the most current parts listing.

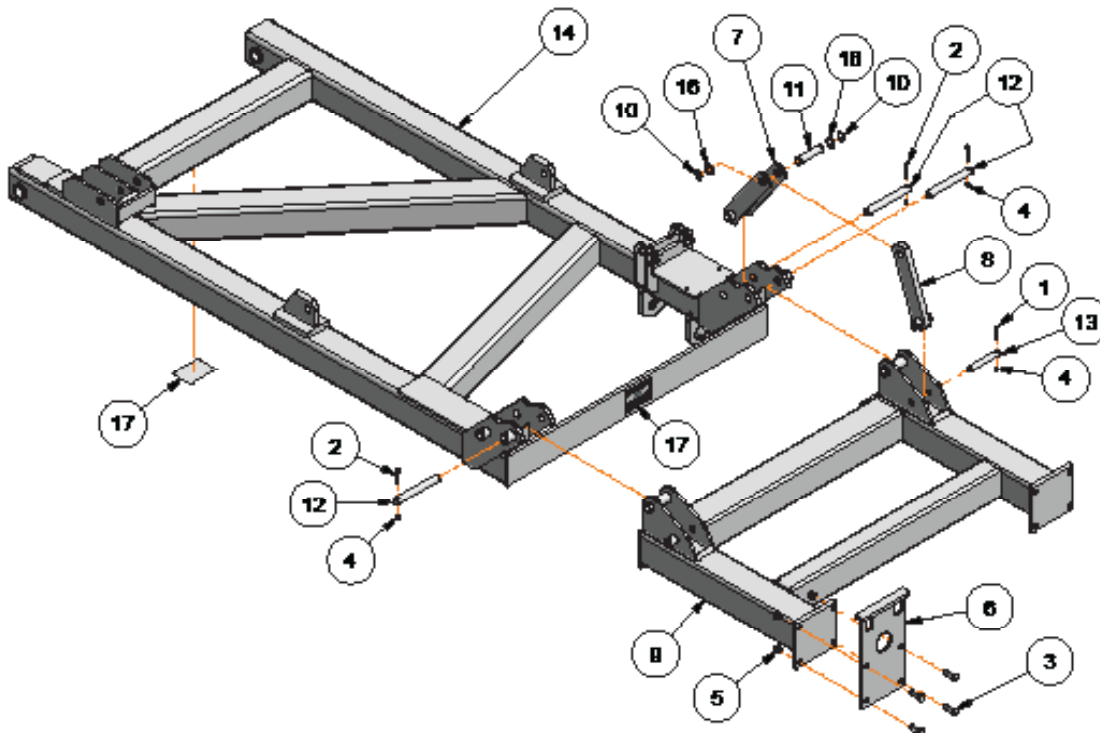
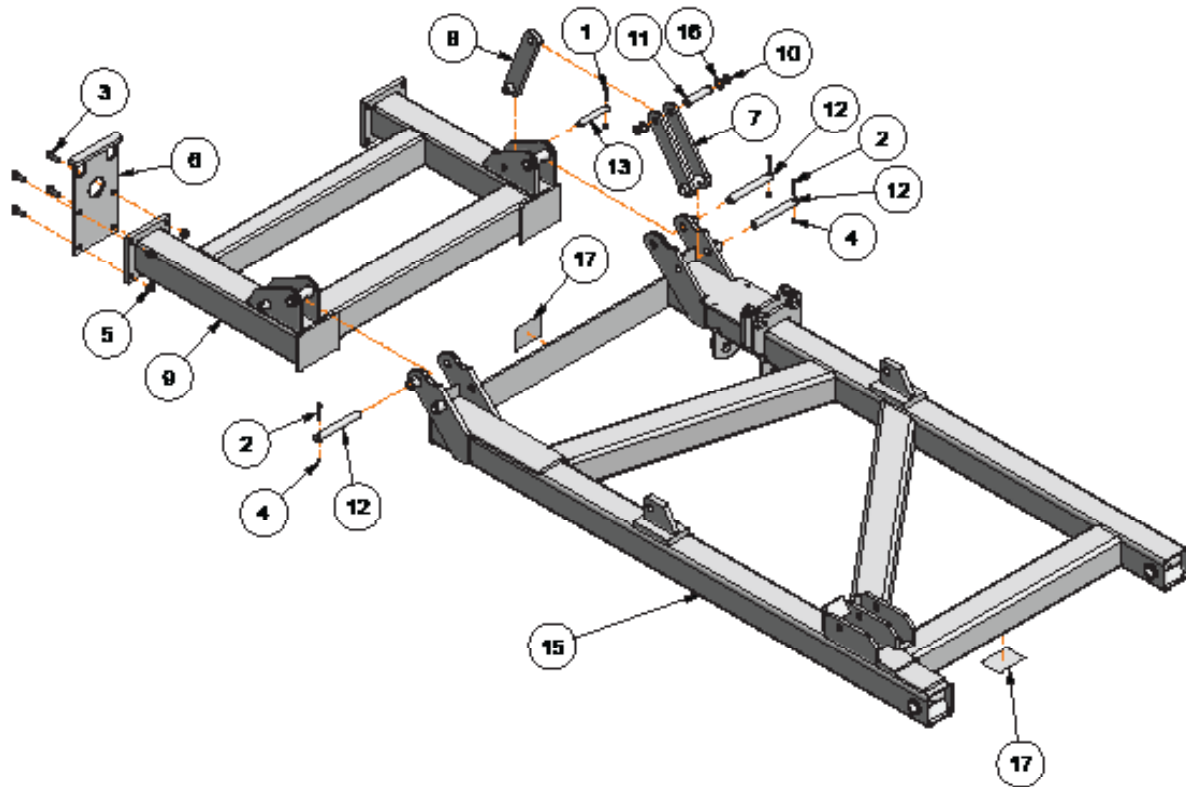

Secondary 3'2" Wing Components

Please visit www.unverferth.com/parts/ for the most current parts listing.

ITEM	PART NUMBER	DESCRIPTION	QTY	NOTES
1	9390-059	Capscrew, 3/8"-16UNC x 2" G5	2	
2	9390-061	Capscrew, 3/8"-16UNC x 2 1/2" G5	6	
3	9390-145	Capscrew, 3/4"-10UNC x 2" G5	8	
4	9398-012	Elastic Lock Nut, 3/8"-16UNC	8	
5	9802	Lock Nut, 3/4"-10UNC	8	
6	JAM4565	Rest Weldment	2	
7	JAM6189	Secondary Wing Linkage Weldment	2	
8	JAM6197	Wing Fold Linkage Weldment	2	
9	JAM6225BB	Secondary Wing, 3'2"	2	
10	JAP2711	Snap Ring 1 1/4", External Heavy-Duty Retaining Ring	4	
11	JBM3548	Pin, 1 1/4" Dia. x 4 3/4"	2	
12	JBM3816	Pin, 1 1/4" Dia. x 9 13/16"	6	
13	JBM3817	Pin, 1" Dia. x 6 7/8"	2	
14	JAM6187BB	Primary Wing, LH	1	
15	JAM6188BB	Primary Wing, RH	1	
16	91174	Machinery Bushing, 1 7/8" OD x 1 1/4" ID x 14GA	4	
17	97337	Decal, WARNING (Wings)	4	

Secondary Wing Extension to 50 Ft.

Please visit www.unverferth.com/parts/ for the most current parts listing.

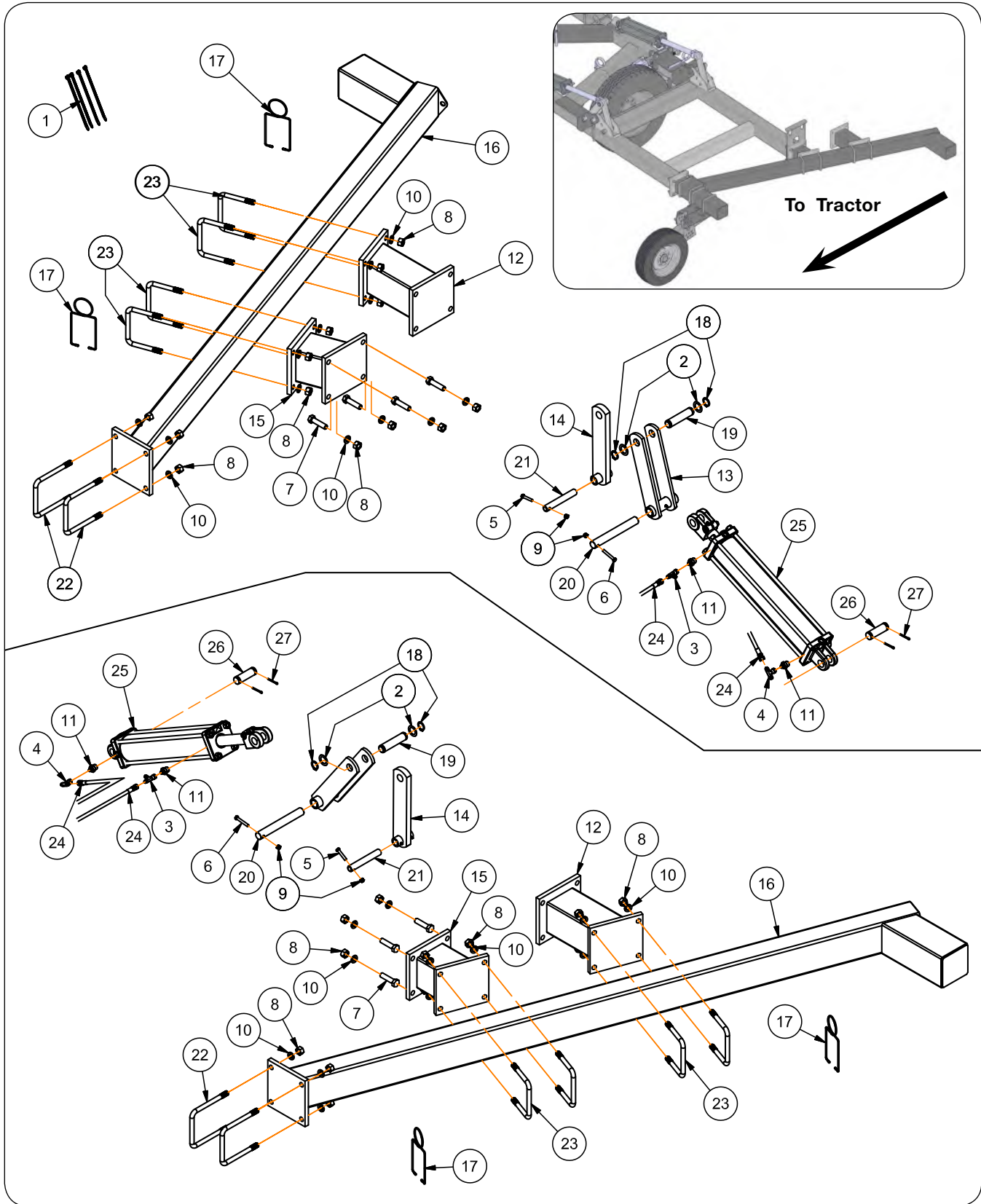

Secondary Wing Extension to 50 Ft.

Please visit www.unverferth.com/parts/ for the most current parts listing.

ITEM	PART NUMBER	DESCRIPTION	QTY	NOTES
1	9003735	Cable Tie 11 x 0.30	4	
2	91174	Machinery Bushing, 1 7/8" OD x 1 1/4" ID x 14GA	4	
3	91465	Tee 9/16-18 JIC Male x 9/16-18 JIC Female x 9/16-18 JIC Male	2	
4	91525	Tee 9/16-18 JIC Male x 9/16-18 JIC Male x 9/16-18 JIC Female	2	
5	9390-059	Capscrew, 3/8"-16UNC x 2" G5	2	
6	9390-061	Capscrew, 3/8"-16UNC x 2 1/2" G5	2	
7	9390-149	Capscrew, 3/4"-10UNC x 3" G5	8	
8	9394-016	Hex Nut, 3/4"-10UNC	32	
9	9398-012	Elastic Lock Nut, 3/8"-16UNC	4	
10	9404-033	Lock Washer, 3/4"	32	
11	98078	Adapter 9/16-18 JIC Male x 7/8-14 O-Ring Male	4	
12	JAM4547BB	Spacer Bracket, 13 1/2"	2	
13	JAM6189	Secondary Wing Linkage Weldment	2	
14	JAM6197	Wing Fold Linkage Weldment	2	
15	JAM6203BB	Spacer Bracket, 8"	2	
16	JAM6204BB	Angled Stagger Bracket	2	
17	JAP2282-1	Hose Retainer (4x6)	4	
18	JAP2711	Snap Ring 1 1/4", External Heavy-Duty Retaining Ring	4	
19	JBM3548	Pin, 1 1/4" Dia. x 4 3/4"	2	
20	JBM3816	Pin, 1 1/4" Dia. x 9 13/16"	2	
21	JBM3817	Pin, 1" Dia. x 6 7/8"	2	
22	JBP3350	U-Bolt, 3/4"-10UNC x 6"W x 7 11/16"L	4	
23	JBP3352	U-Bolt, 3/4"-10UNC x 6"W x 5 11/16"L	8	
24	JDP5055	Hose, 1/4" x 66" (9/16-18 JIC Female x 9/16-18 JIC Female)	4	
25	JDP4579	Cylinder, 4 1/2" x 20"	2	Includes Items 26 & 27
26	N/A	Pin, 1 1/4" Dia. x 3 3/16"	2	Included with Item 25
27	N/A	Cotter Pin, 3/16" Dia. x 1 3/4"	4	Included with Item 25

Straight Extension Kit

Please visit www.unverferth.com/parts/ for the most current parts listing.

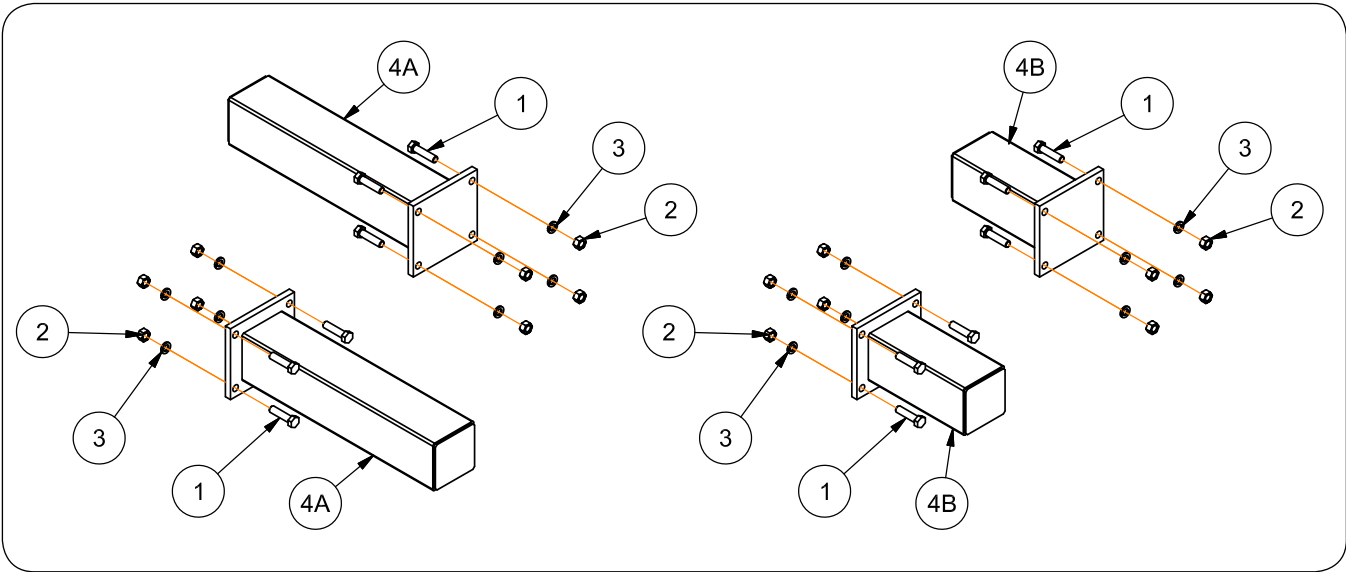

ITEM	PART NUMBER	DESCRIPTION	QTY	NOTES
	J55000106BB	Straight Extension Kit 28" Bundle	-	Includes Items 1-4A
	J55000107	Straight Extension Kit 14" Bundle	-	Includes Items 1-4B
1	9390-149	Capscrew, 3/4"-10UNC x 3" G5	8	
2	9394-016	Hex Nut, 3/4"-10UNC	8	
3	9404-033	Lock Washer, 3/4"	8	
4A	JAM4544BB	Extension Bracket 28"	2	
4B	JAM4546	Extension Bracket 14"	2	

Pin Adjust Gauge Wheel Leg Assembly (JAM24024)

Please visit www.unverferth.com/parts/ for the most current parts listing.

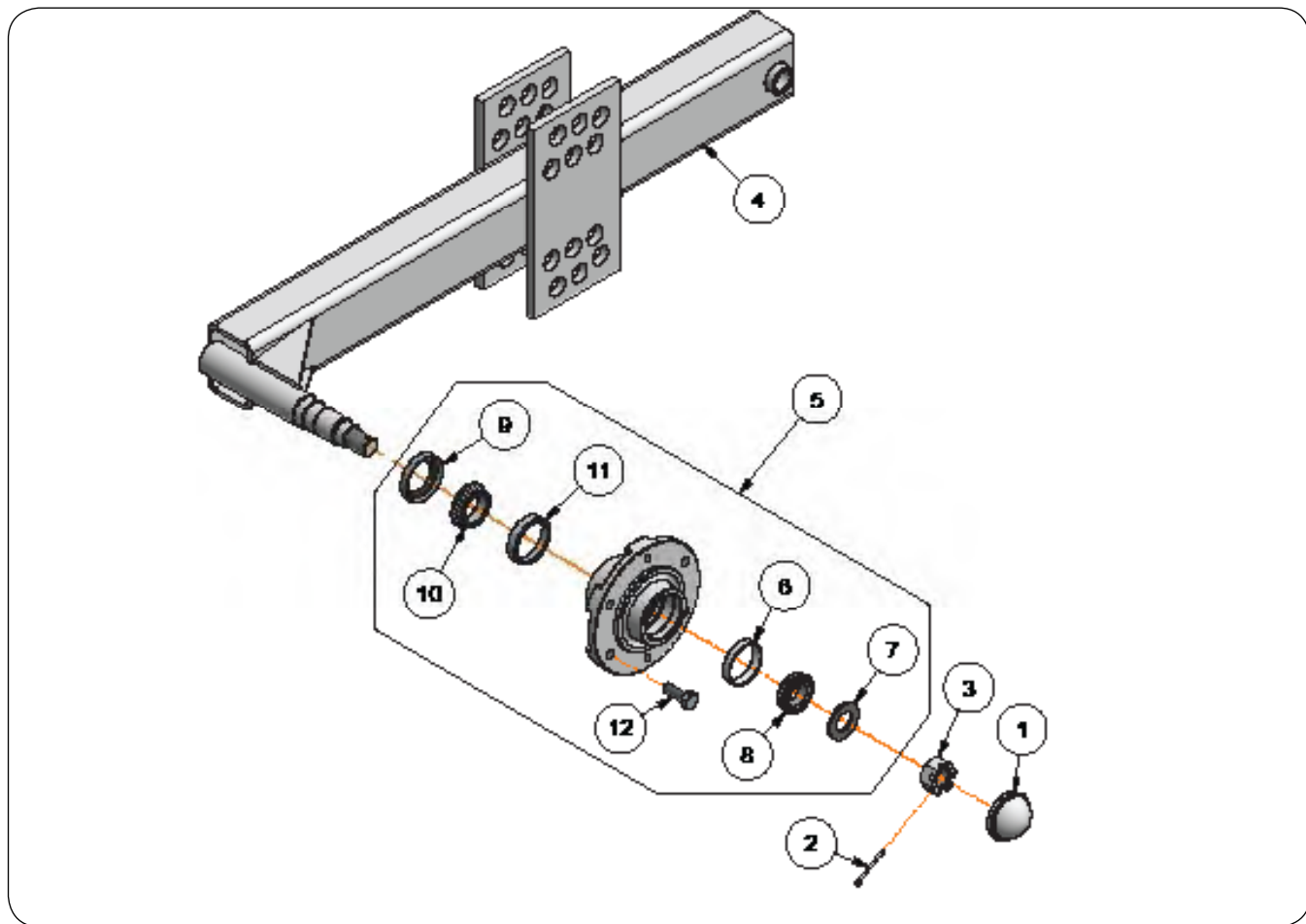

ITEM	PART NUMBER	DESCRIPTION	QTY
1	9162	Hub Cap	1
2	9391-036	Cotter Pin, 5/32" Dia. x 1 3/4"	1
3	9393-020	Slotted Nut, 1"-14UNS	1
4	JEM3700	Gauge Wheel Leg Weldment, Pin Adjust	1
5	9503448B	Hub 6-Bolt Assembly	1
6	9345	Bearing Cup, 2.328" Dia. (LM67010)	1
7	JAP2146	Spindle Washer, 2" O.D. x 1.063" I.D.	1
8	9165	Bearing Cone, 1.25" Bore (LM67048)	1
9	91833	Seal, 2.562" O.D. x 1.625" I.D. , Single Lip (CR16289)	1
10	91818	Bearing Cone, 1.496" Bore (JL69349)	1
11	91815	Bearing Cup, 2.48" Dia. (JL69310)	1
12	91831	Wheel Bolt, 1/2"-20UNF x 1 1/4" G5	6

Dual Wheel Lift with 385/65R22.5 Tires (J66000127)

Please visit www.unverferth.com/parts/ for the most current parts listing.

Right-Hand Wheel Leg

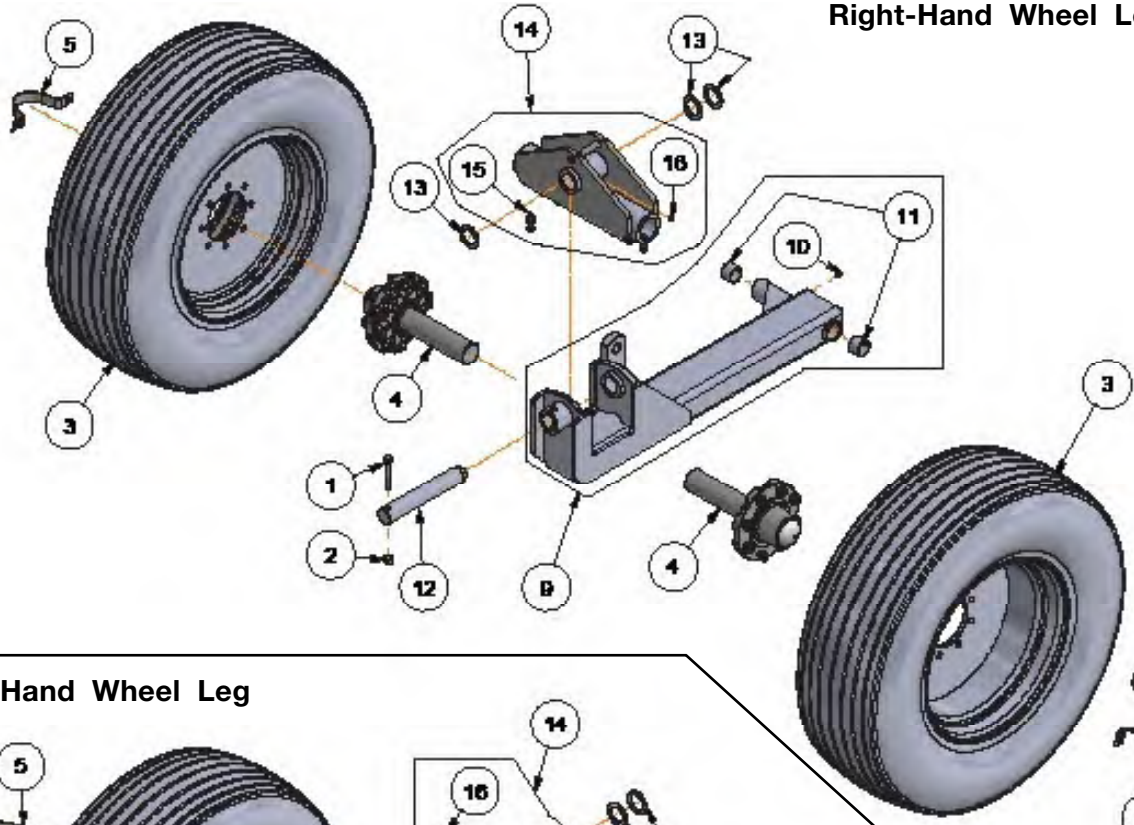

Left-Hand Wheel Leg

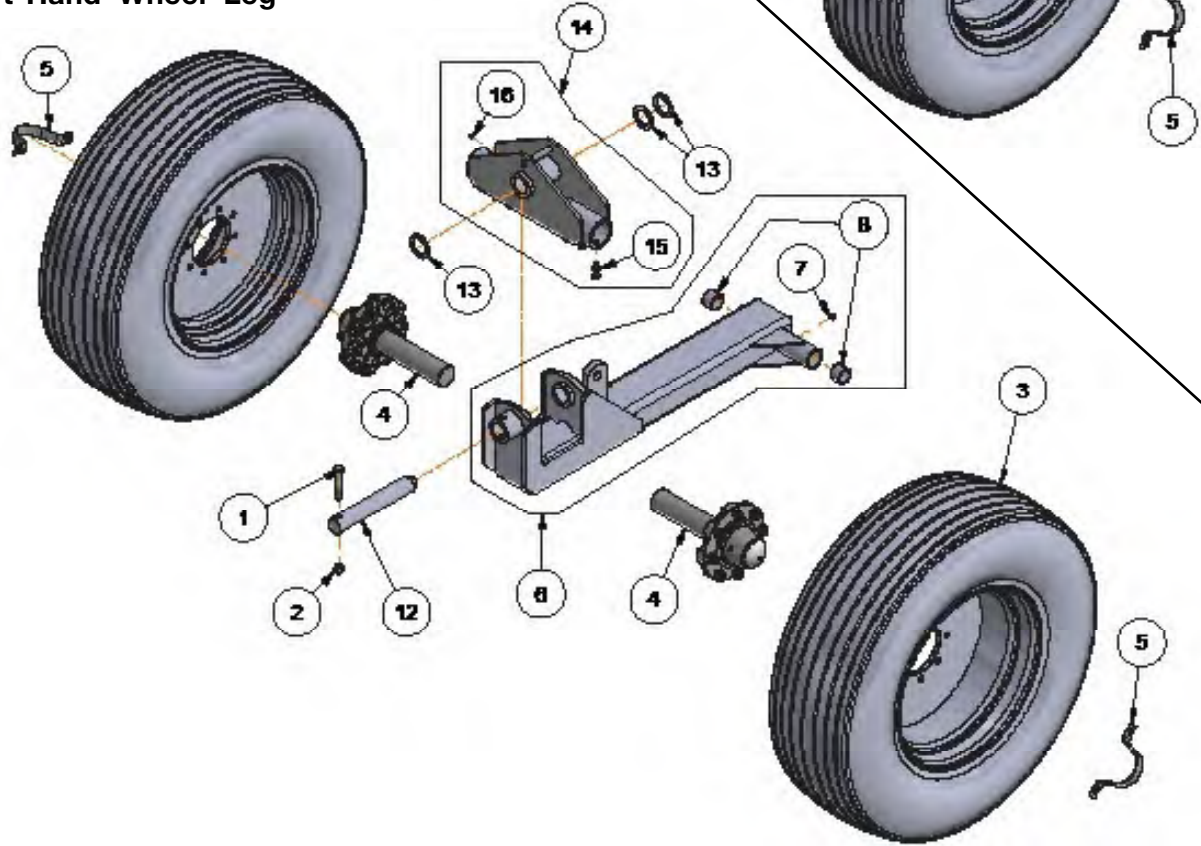

Dual Wheel Lift with 385/65R22.5 Tires (J66000127)

Please visit www.unverferth.com/parts/ for the most current parts listing.

ITEM	PART NUMBER	DESCRIPTION	QTY	NOTES
1	9390-132	Capscrew, 5/8"-11UNC x 4" G5	2	
2	9398-019	Elastic Lock Nut, 5/8"-11UNC	2	
3	111274SM	Wheel and Tire Assembly 11.75x22.5/65R22.5	4	Includes Valve Stem, Tire & Wheel
	93300	Valve Stem	4	
	N/A	Tire TLVF385/65R22.5F	4	
	111146SM	Wheel 11.75 x 22.5 (8 Bolt)	4	
4	JAAM2800-1	Hub and Spindle Assembly	4	
5	JAM4597	Hub Cap Strap	4	
6	JAM6173	Wheel Leg Weldment, LH	1	Includes Items 7 & 8
7	93415	Grease Zerk 90°	1	
8	JBP3538	Split Tension Bushing 2" OD x 1 3/4" ID x 1 1/2"	2	
9	JAM6174	Wheel Leg Weldment, RH	1	Includes Items 10 & 11
10	93415	Grease Zerk 90°	1	
11	JBP3538	Split Tension Bushing 2" OD x 1 3/4" ID x 1 1/2"	2	
12	JBM3640	Pin, 2" Dia. x 12 5/8"	2	
13	JBP3599	Machinery Bushing 3" OD x 2" ID x 10GA	6	
14	JAM6198	Duals, Rocker with Spindle Loops For 2 3/4" Spindle	2	Includes Items 15 & 16
15	JEM3301	Set Screw & Jam Nut 5/8"-11UNC Assembly	6	
16	91160	Grease Zerk 1/4"-28 STT	1	

Dual Wheel Lift with 295/75R22.5 Tires (J66000124)

Please visit www.unverferth.com/parts/ for the most current parts listing.

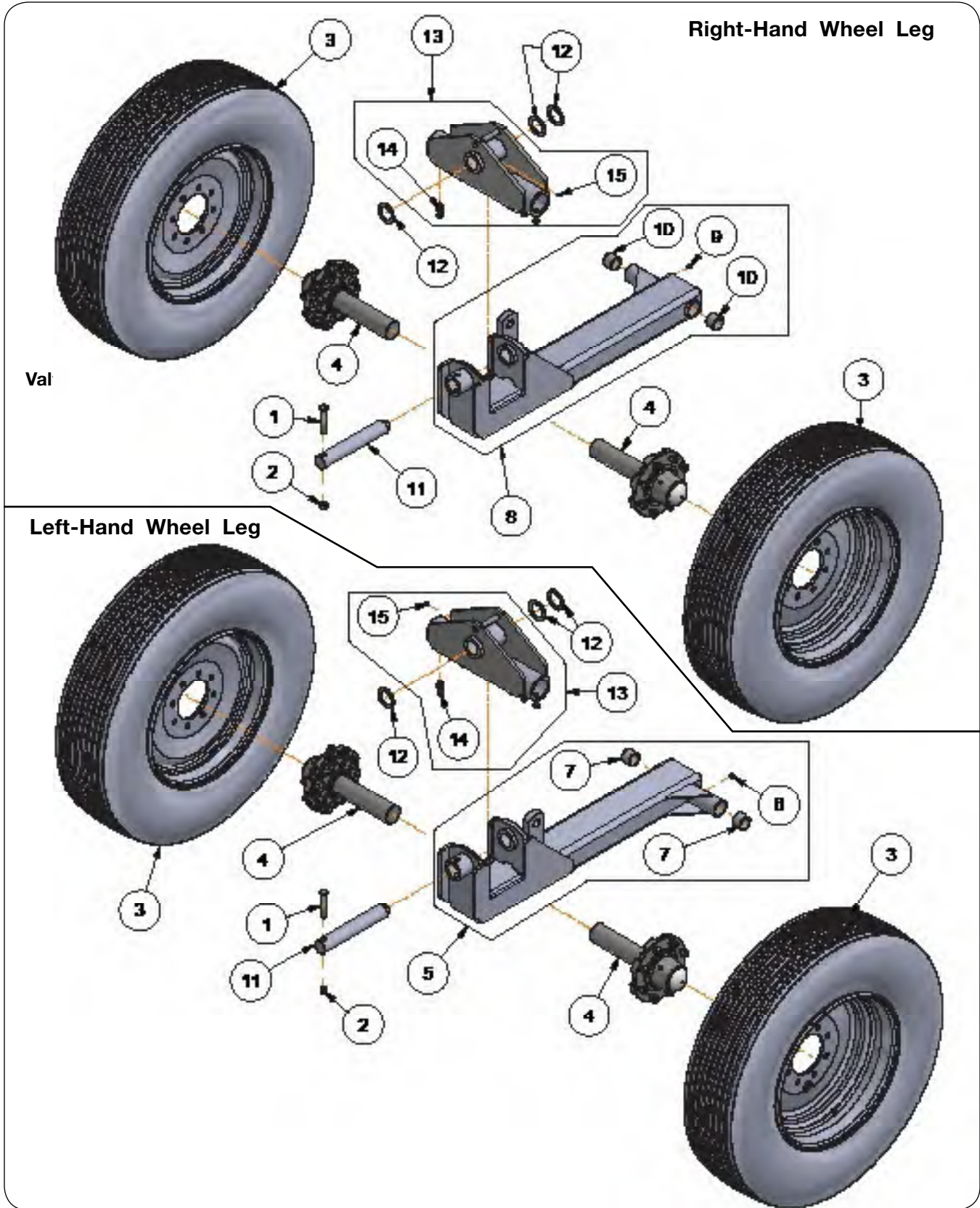

Dual Wheel Lift with 295/75R22.5 Tires (J66000124)

Please visit www.unverferth.com/parts/ for the most current parts listing.

ITEM	PART NUMBER	DESCRIPTION	QTY	NOTES
	J66000124	Dual Wheel Lift with 295/75R22.5 Tires	-	Includes Items 1-15
1	9390-132	Capscrew, 5/8"-11UNC x 4" G5	2	
2	9398-019	Elastic Lock Nut, 5/8"-11UNC	2	
3	111275SM	Wheel and Tire Assembly 8.25 x 22.5/10.6 x 22.5	4	Includes Valve Stem, Tire & Wheel
	9817	Valve Stem	4	
	9502085	Tire TLVF295/75R22.5F	4	
	W8.2522.5-8SM	Wheel 8.25 x 22.5 (8 Bolt)	4	
4	JAAM2800	Hub and Spindle Assembly	4	
5	JAM6173	Wheel Leg Weldment, LH	1	Includes Items 6 & 7
6	93415	Grease Zerk 90°	1	
7	JBP3538	Split Tension Bushing 2" OD x 1 3/4" ID x 1 1/2"	2	
8	JAM6174	Wheel Leg Weldment, RH	1	Includes Items 9 & 10
9	93415	Grease Zerk 90°	1	
10	JBP3538	Split Tension Bushing 2" OD x 1 3/4" ID x 1 1/2"	2	
11	JBM3640	Pin, 2" Dia. x 12 5/8"	2	
12	JBP3599	Machinery Bushing 3" OD x 2" ID x 10GA	6	
13	JAM6198	Duals, Rocker with Spindle Loops For 2 3/4" Spindle	2	Includes Items 14 & 15
14	JEM3301	Set Screw & Jam Nut 5/8"-11UNC Assembly	6	
15	91160	Grease Zerk 1/4"-28 STT	1	

Single Wheel Lift Components (J66000104)

Please visit www.unverferth.com/parts/ for the most current parts listing.

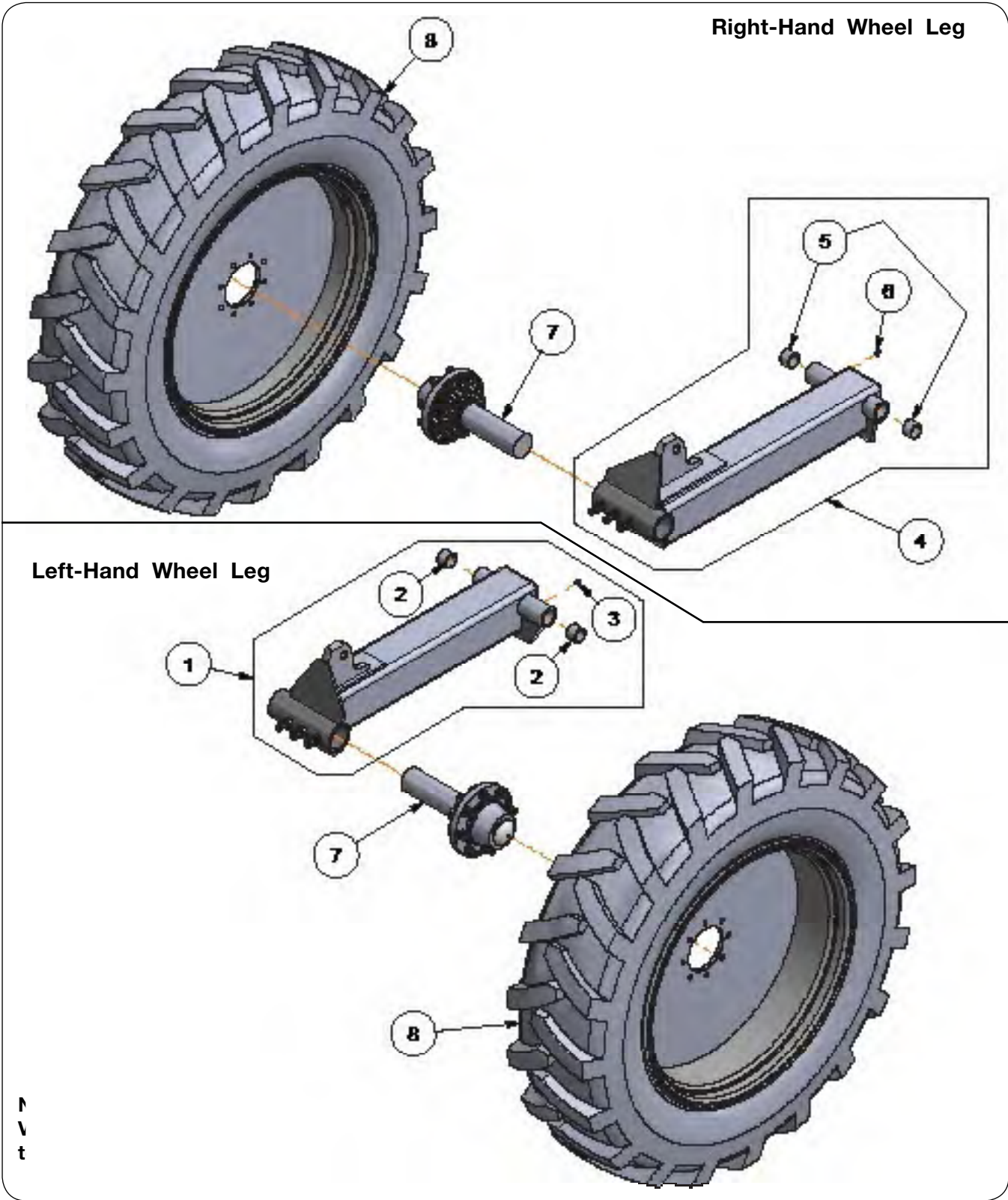

Single Wheel Lift Components (J66000104)

Please visit www.unverferth.com/parts/ for the most current parts listing.

ITEM	PART NUMBER	DESCRIPTION	QTY	NOTES
1	JAM6226	Wheel Leg Weldment, LH	1	Includes Items 2 & 3
2	JBP3538	Split Tension Bushing 2" OD x 1 3/4" ID x 1 1/2"	2	
3	93415	Grease Zerk 90°	1	
4	JAM6227	Wheel Leg Weldment, RH	1	Includes Items 5 & 6
5	JBP3538	Split Tension Bushing 2" OD x 1 3/4" ID x 1 1/2"	2	
6	93415	Grease Zerk 90°	1	
7	JAAM2788-1	Hub and Spindle Assembly	2	
8	111273SM	Wheel and Tire Assembly 13x34/TL380/85R34	1	Includes Valve Stem, Tire & Wheel
	93300	Valve Stem	2	
	N/A	Tire TL380/85R34MT R-1W	2	
	111144SM	Wheel 13x34 (8 Bolt)	2	

**Hub and Spindle Components (JAAM2800)
For 295/75R22.5 Tires**

Please visit www.unverferth.com/parts/ for the most current parts listing.

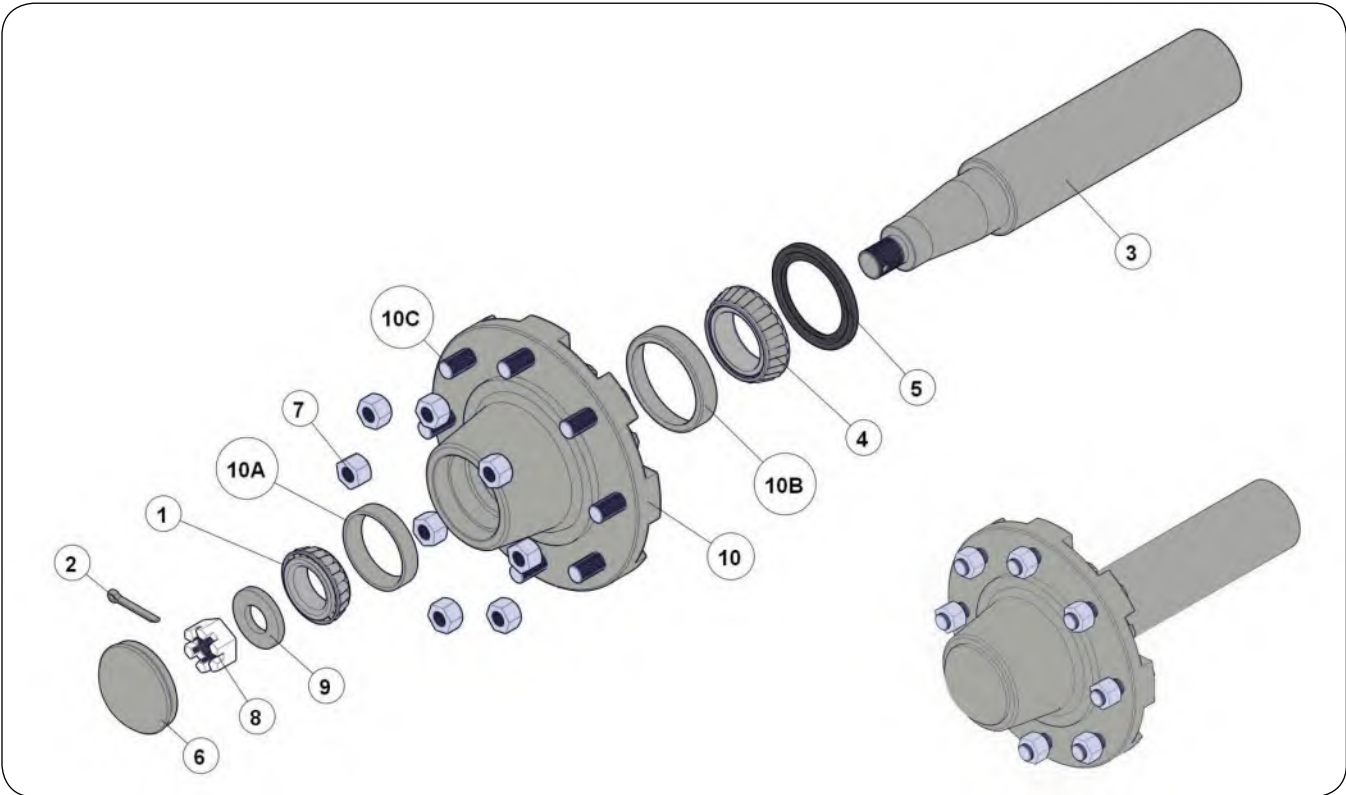

ITEM	PART NUMBER	DESCRIPTION	QTY	NOTES
1	9247	Bearing Cone, 1.625" Bore (LM501349)	1	
2	TA37809	Cotter Pin, 7/32" Dia. x 1 3/4"	1	
3	JAP2171	Spindle, 2 3/4" x 16"	1	
4	92610	Bearing Cone, 2.165" Bore (JLM506849)	1	
5	92612	Seal (CR27394)	1	
6	9442B	Hub Cap, 3.125" Dia.	1	
7	9610	Wheel Nut, 5/8"-18UNF G5	8	
8	9393-020	Slotted Nut, 1"-14UNS	1	
9	9448	Flat Washer, 1"	1	
10	91854	Hub with Cups, 8-Bolt (2816390)	1	Includes 10A, 10B, 10C
10A	9349	Bearing Cup, 2.891" OD (LM501310)	1	
10B	91809	Bearing Cup, 3.5433" OD (JLM506810)	1	
10C	9007746	Stud Bolt, 5/8"-18UNF x 2 1/4" G5	8	

**Hub and Spindle Components (JAAM2800-1)
For 385/65R22.5 Tires**

Please visit www.unverferth.com/parts/ for the most current parts listing.

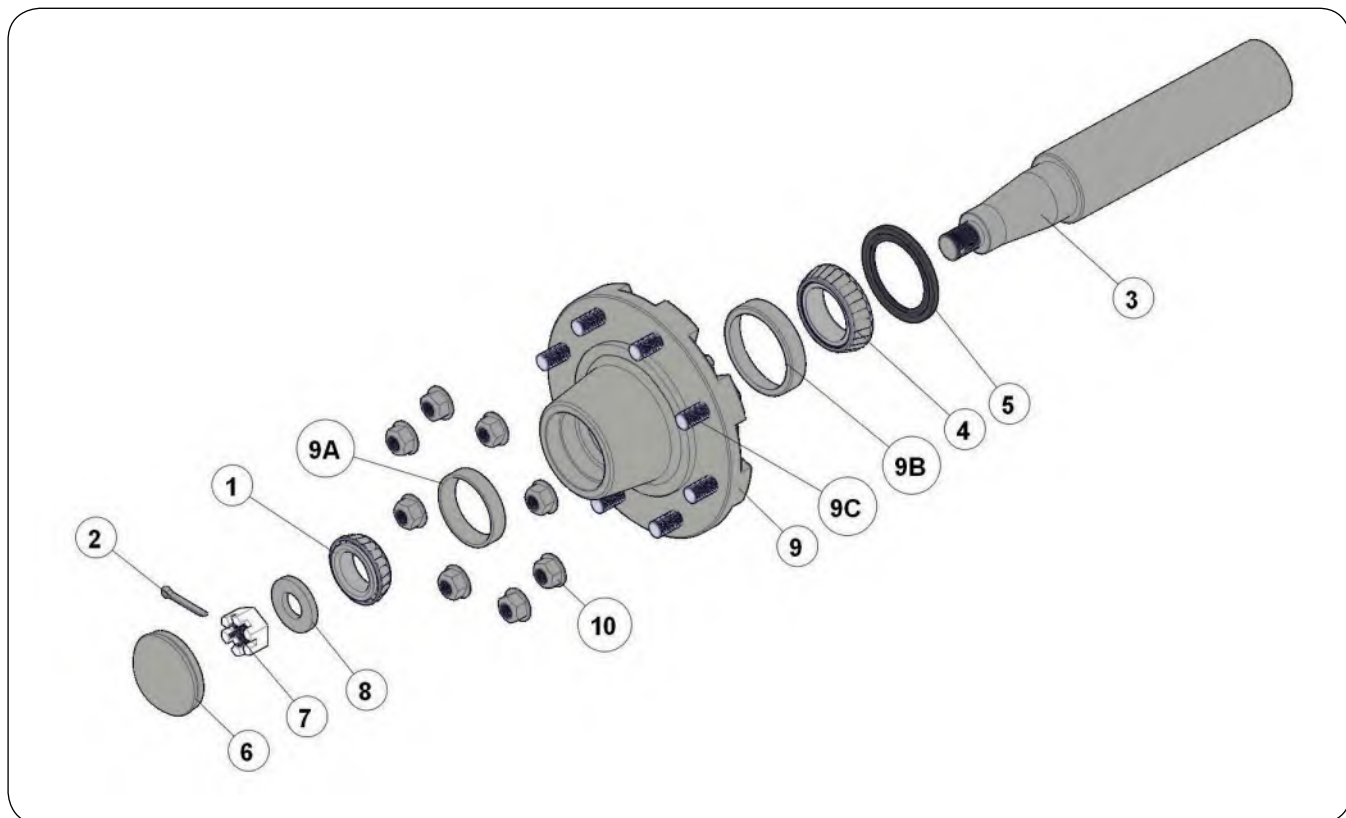

ITEM	PART NUMBER	DESCRIPTION	QTY	NOTES
1	9247	Bearing Cone, 1.625" Bore (LM501349)	1	
2	TA37809	Cotter Pin, 7/32" Dia. x 1 3/4"	1	
3	JAP2171	Spindle, 2 3/4" x 16"	1	
4	92610	Bearing Cone, 2.165" Bore (JLM506849)	1	
5	92612	Seal (CR27394)	1	
6	9442B	Hub Cap, 3.125" Dia.	1	
7	9393-020	Slotted Nut, 1"-14UNS	1	
8	9448	Flat Washer, 1"	1	
9	91854	Hub with Cups, 8-Bolt (2816390)	1	Includes 9A, 9B, 9C
9A	9349	Bearing Cup, 2.891" OD (LM501310)	1	
9B	91809	Bearing Cup, 3.5433" OD (JLM506810)	1	
9C	9007746	Stud Bolt, 5/8"-18UNF x 2 1/4" G5	8	
10	9002237	Flange Nut, 5/8"-18UNF G8	8	

**Hub and Spindle Components (JAAM2788-1)
For 385/85R34 Tires**

Please visit www.unverferth.com/parts/ for the most current parts listing.

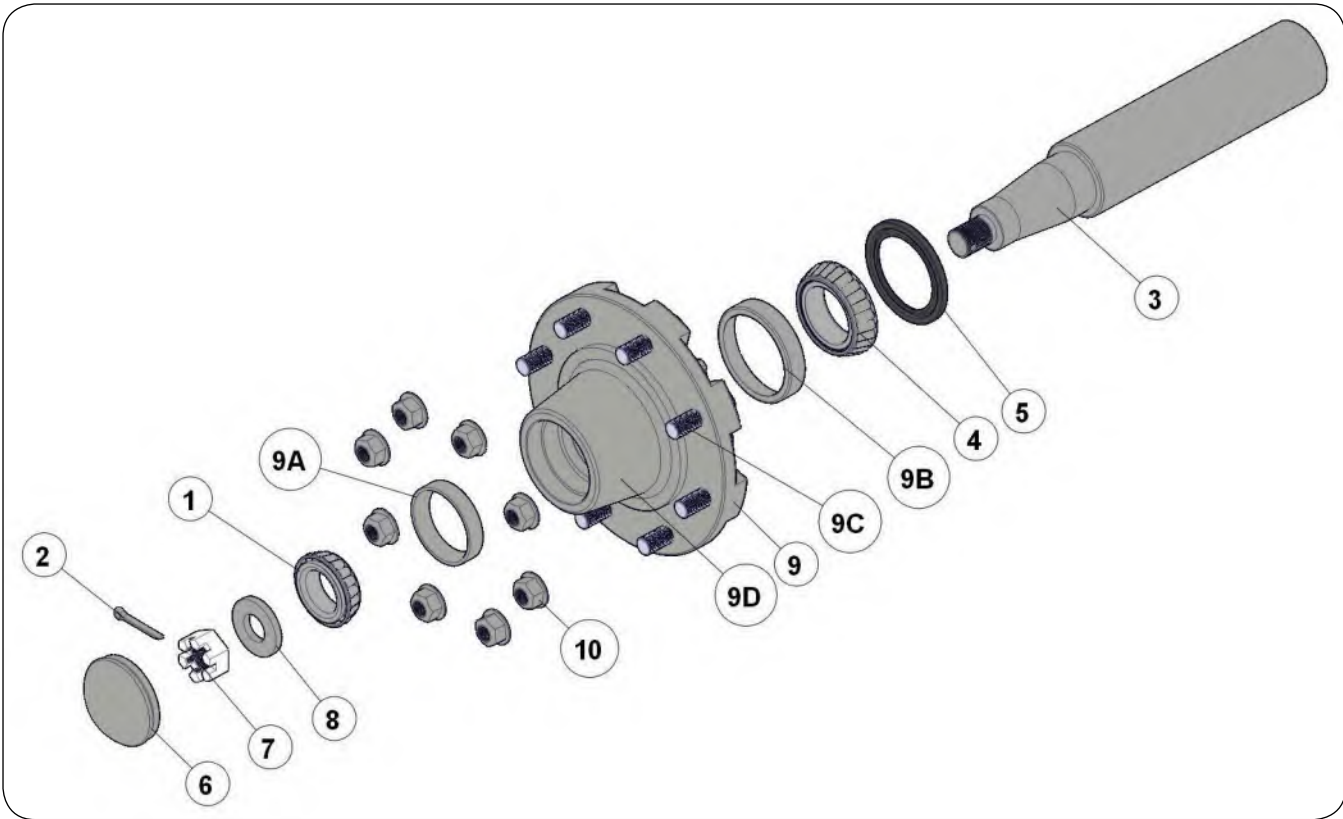

ITEM	PART NUMBER	DESCRIPTION	QTY	NOTES
1	9247	Bearing Cone, 1.625" Bore (LM501349)	1	
2	TA37809	Cotter Pin, 7/32" Dia. x 1 3/4"	1	
3	9442B	Hub Cap, 3.125" Dia.	1	
4	9393-020	Slotted Nut, 1"-14UNS	1	
5	9448	Flat Washer, 1"	1	
6	9443	Bearing Cone, 2.25" ID (387AS)	1	
7	9445	Seal (29968)	1	
8	JAP2941	Spindle, 3" x 16"	1	
9	9441	Hub with Cups, 8-Bolt (107901)	1	Includes 9A, 9B, 9C, 9D
9A	9349	Bearing Cup, 2.891" OD (LM501310)	1	
9B	9612	Bearing Cup, 3.813" OD (382-A)	1	
9C	9223	Stud Bolt, 5/8"-18UNF x 2.75" G8	8	
9D	N/A	Hub, 8-Bolt	1	
10	9002237	Flange Nut, 5/8"-18UNF G8	8	

Legacy — Parts

Decals

Please visit www.unverferth.com/parts/ for the most current parts listing.

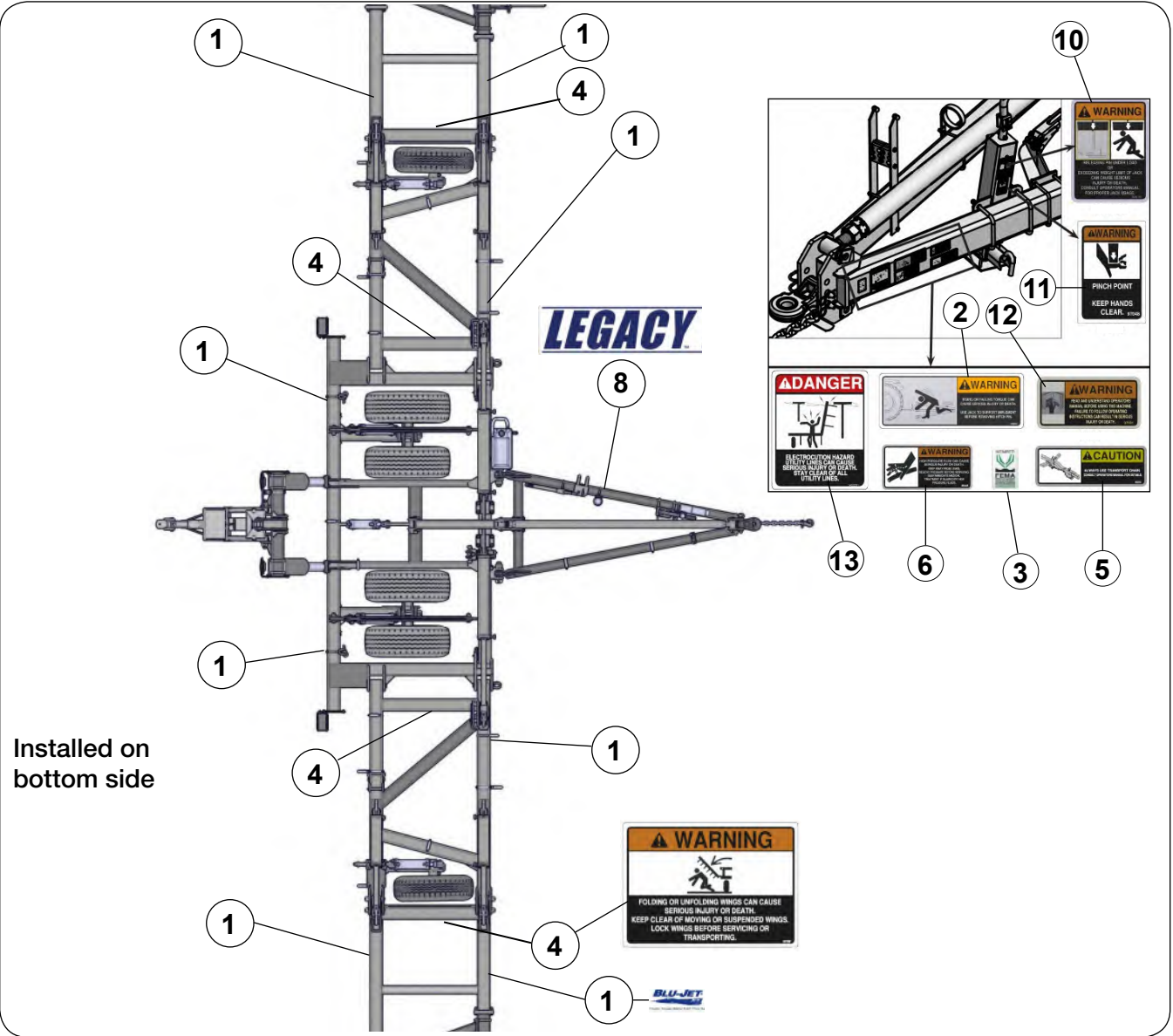

ITEM	PART NUMBER	DESCRIPTION	QTY	NOTES
1	JAP2215	Decal, BLU-JET, 3" X 8"	8	
2	94094	Decal, WARNING "Rising or Falling Tongue"	1	
3	91605	Decal, FEMA	1	
4	97337	Decal, WARNING "Folding or Unfolding Wings"	4	
5	97575	Decal, CAUTION "Transport Chain"	1	
6	95445	Decal, WARNING "High-Pressure Fluid"	1	
8	JAP2554	Decal, LEGACY 4.75" X 20.75"	2	
10	9501197	Decal, WARNING "Releasing Pin Under Load"	1	
11	97048	Decal, WARNING "Pinch Point"	1	
12	97961	Decal, WARNING "Read and Understand"	1	
13	902221	Decal, DANGER "Electrocution Hazard"	1	

Main Frame to Primary Wing Hydraulics

Please visit www.unverferth.com/parts/ for the most current parts listing.

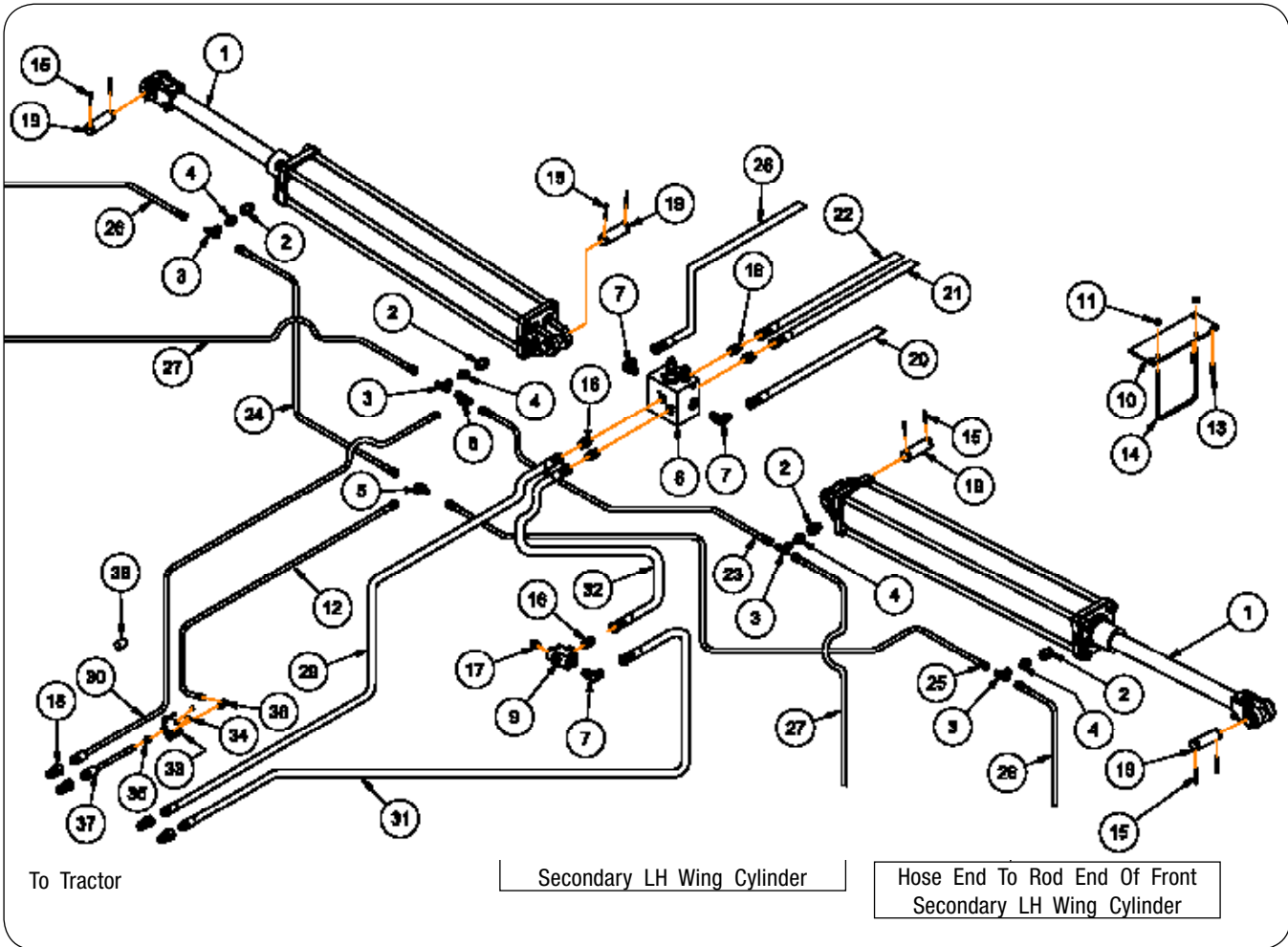

Main Frame to Primary Wing Hydraulics

Please visit www.unverferth.com/parts/ for the most current parts listing.

ITEM	PART NUMBER	DESCRIPTION	QTY	NOTES
1	JDP4398-1	Cylinder 5" x 36" w/2 3/4" Spacer	2	
2	98801	Reducer 7/8-14 O-Ring Male x 3/4-16 O-Ring Female	4	
3	91525	Tee 9/16-18 JIC Male x 9/16-18 JIC Male x 9/16-18 JIC Female	6	
4	99611	Adapter 9/16-18 JIC Male x 3/4-16 O-Ring Male w/0.90 Restrictor	4	
5	9875	Tee 9/16-18 JIC Male x 9/16-18 JIC Male x 9/16-18 JIC Male	1	
6	91465	Tee 9/16-18 JIC Male x 9/16-18 JIC Female x 9/16-18 JIC Male	3	
7	98201	90° Elbow 7/8-14 JIC Male x 3/4-16 O-Ring Male	13	
8	JDP4590	Valve Assembly - Flow Divider with Holding Valves	1	
9	9002151	Remote Stroke Control Valve	1	
10	JAM6159	Flow Divider Valve Mount Bracket	1	
11	9928	Lock Nut/Top, 3/8"-16UNC	6	
12	91203	Hydraulic Hose, 3/8" x 108" (9/16-18 JIC Female x 9/16-18 JIC Female)	1	
13	9390-055	Capscrew, 3/8"-16UNC x 1" G5	2	
14	JBP3351	U-Bolt, 3/8"-16UNC x 7", 6 7/16CC	3	
15	9391-045	Cotter Pin, 3/16" Dia. x 1 3/4"	8	
16	9503026	Adapter 7/8-14 JIC Male x 3/4-16 O-Ring Male	5	
17	93657	Plug 3/4-16 O-Ring Male Hex Head	1	
18	91383	Male Tip Coupling 3/4-16 O-Ring Female	4	
19	JBP3498	Clevis Pin, 1 1/4" Dia. x 3 3/16"	4	
20	JDP4496	Hydraulic Hose, 1/2" x 114" (7/8-14 JIC Female x 7/8-14 JIC Female)	1	
21	JDP5001	Hydraulic Hose, 1/2" x 168" (7/8-14 JIC Female x 7/8-14 JIC Female)	1	
22	JDP5186	Hydraulic Hose, 1/2" x 132" (7/8-14 JIC Female x 7/8-14 JIC Female)	1	
23	JDP5308	Hydraulic Hose, 3/8" x 32" (9/16-18 JIC Female x 9/16-18 JIC Female)	1	
24	JDP5309	Hydraulic Hose, 3/8" x 43" (9/16-18 JIC Female x 9/16-18 JIC Female)	1	
25	JDP5310	Hydraulic Hose, 3/8" x 77" (9/16-18 JIC Female x 9/16-18 JIC Female)	1	
26	JDP5311	Hydraulic Hose, 3/8" x 134" (9/16-18 JIC Female x 9/16-18 JIC Female)	2	
27	JDP5312	Hydraulic Hose, 3/8" x 143" (9/16-18 JIC Female x 9/16-18 JIC Female)	2	
28	JDP5316	Hydraulic Hose, 1/2" x 353" (7/8-14 JIC Female x 7/8-14 JIC Female)	1	
29	JDP5317	Hydraulic Hose, 1/2" x 240" (7/8-14 JIC Female x 3/4-16 O-Ring Male)	1	
30	9504312	Hydraulic Hose, 3/8" x 230" (9/16-18 JIC Female x 3/4-16 O-Ring Male)	1	
31	JDP5349	Hydraulic Hose, 1/2" x 264" (7/8-14 JIC Female x 3/4-16 O-Ring Male)	1	
32	JDP5230	Hydraulic Hose, 1/2" x 42" (7/8-14 JIC Female x 7/8-14 JIC Female)	1	
33	JDP3993	Hydraulic Check Valve w/Manual Release	1	
34	9807	Lock Nut/Top, 5/16"-18UNC	2	
35	92927	Adapter, 9/16-18 JIC Male x 3/4-16 O-Ring Male	1	
36	9874	90° Elbow, 9/16-18 JIC Male x 3/4-16 O-Ring Male	1	
37	96756	Hydraulic Hose, 3/8" x 140" (9/16-18 JIC Female x 3/4-16 O-Ring Male)	1	
38	9007463	Hose Marker RED, Main Lift Down	1	
	9007464	Hose Marker RED, Main Lift Up	1	
	9007467	Hose Marker GRAY, Wing Fold In	1	
	9007468	Hose Marker GRAY, Wing Fold Out	1	

Main Frame Transport Wheel & Depth Control Hydraulics

Please visit www.unverferth.com/parts/ for the most current parts listing.

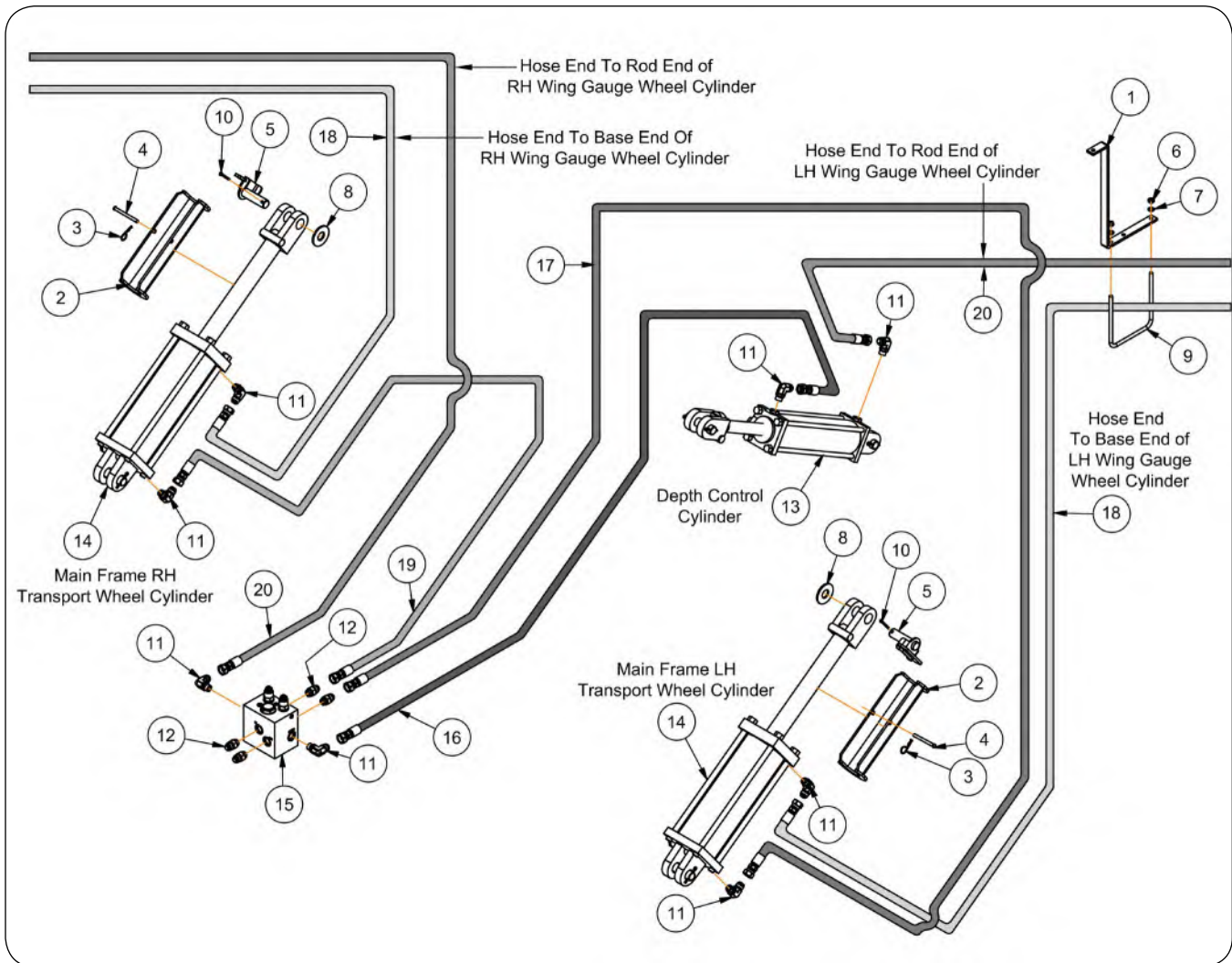

Main Frame Transport Wheel & Depth Control Hydraulics

Please visit www.unverferth.com/parts/ for the most current parts listing.

ITEM	PART NUMBER	DESCRIPTION	QTY	NOTES
1	JAM2090	Depth Collar & Lock-Up Storage Bracket	2	
2	JAM6280	Transport Lock	2	
3	9514	Hairpin Cotter 0.092" Dia. x 1 7/8"	2	
4	9503240	Clevis Pin 5/16" Dia. x 3 1/2"	2	
5	JBM3559	Clevis Pin Weldment 1" Dia. x 3 7/8"	4	
6	9394-006	Hex Nut, 3/8"-16UNC	6	
7	9404-021	Lock Washer, 3/8"	8	
8	9405-118	Flat Washer, 1" USS	4	
9	JBP3351	U-Bolt, 3/8"-16UNC x 7", 6 7/16CC	3	
10	9391-045	Cotter Pin, 3/16" Dia. x 1 3/4"	4	
11	98201	90° Elbow 7/8-14 JIC Male x 3/4-16 O-Ring Male	13	
12	9503026	Adapter 7/8-14 JIC Male x 3/4-16 O-Ring Male	5	
13	JDP4485	Rephase Cylinder, 3 3/4" x 12"	1	
14	JDP4487	Rephase Cylinder, 4 1/2" x 12"	2	
15	JDP4590	Valve Assembly - Flow Divider with Holding Valves	1	
16	JDP4496	Hydraulic Hose, 1/2" x 114" (7/8-14 JIC Female x 7/8-14 JIC Female)	1	
17	JDP5001	Hydraulic Hose, 1/2" x 168" (7/8-14 JIC Female x 7/8-14 JIC Female)	1	
18	JDP5184	Hydraulic Hose, 1/2" x 192" (7/8-14 JIC Female x 7/8-14 JIC Female)	2	
19	JDP5186	Hydraulic Hose, 1/2" x 132" (7/8-14 JIC Female x 7/8-14 JIC Female)	1	
20	JDP5235	Hydraulic Hose, 1/2" x 252" (7/8-14 JIC Female x 7/8-14 JIC Female)	2	

Wing Gauge Wheel Hydraulics

Please visit www.unverferth.com/parts/ for the most current parts listing.

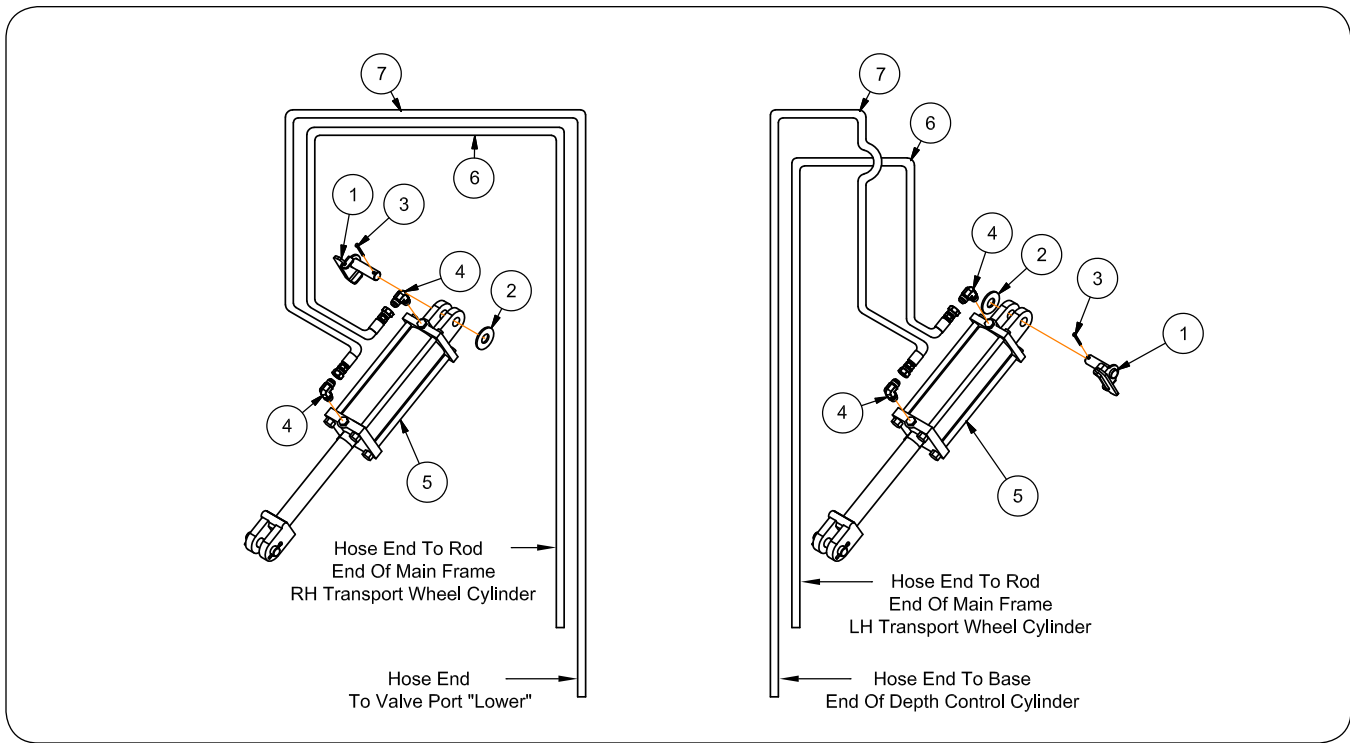

ITEM	PART NUMBER	DESCRIPTION	QTY	NOTES
1	JBM3559	Clevis Pin Weldment 1" Dia. x 3 7/8"	4	
2	9405-118	Flat Washer, 1" USS	4	
3	9391-045	Cotter Pin, 3/16" Dia. x 1 3/4"	4	
4	98201	90° Elbow 7/8-14 JIC Male x 3/4-16 O-Ring Male	13	
5	JDP4486	Rephase Cylinder, 4" x 12"	2	
6	JDP5184	Hydraulic Hose, 1/2" x 192" (7/8-14 JIC Female x 7/8-14 JIC Female)	2	
7	JDP5235	Hydraulic Hose, 1/2" x 252" (7/8-14 JIC Female x 7/8-14 JIC Female)	2	

Primary Wing to Secondary Wing Hydraulics

Please visit www.unverferth.com/parts/ for the most current parts listing.

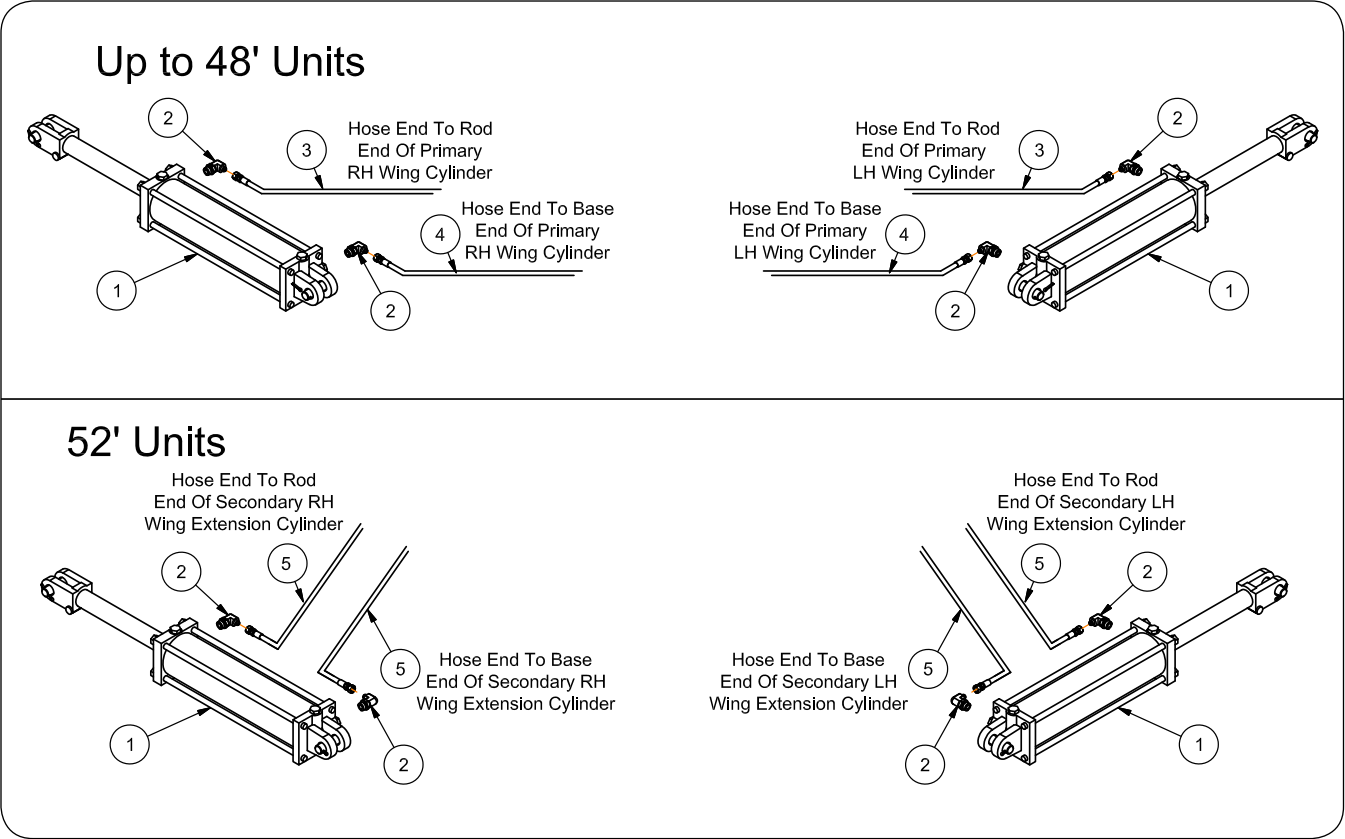

ITEM	PART NUMBER	DESCRIPTION	QTY	NOTES
1	JDP4579	Cylinder 4 1/2" x 20"	2	
2	98079	90° Elbow 916-18 JIC Male x 7/8-14 O-Ring Male	4	
3	JDP5314	Hydraulic Hose, 3/8" x 152" (9/16-18 JIC Female x 9/16-18 JIC Female)	2	
4	JDP5315	Hydraulic Hose, 3/8" x 168" (9/16-18 JIC Female x 9/16-18 JIC Female)	2	
5	JDP5055	Hydraulic Hose, 1/4" x 66" (9/16-18 JIC Female x 9/16-18 JIC Female)	4	

Secondary Wing Extension Hydraulics (52' Units ONLY)

Please visit www.unverferth.com/parts/ for the most current parts listing.

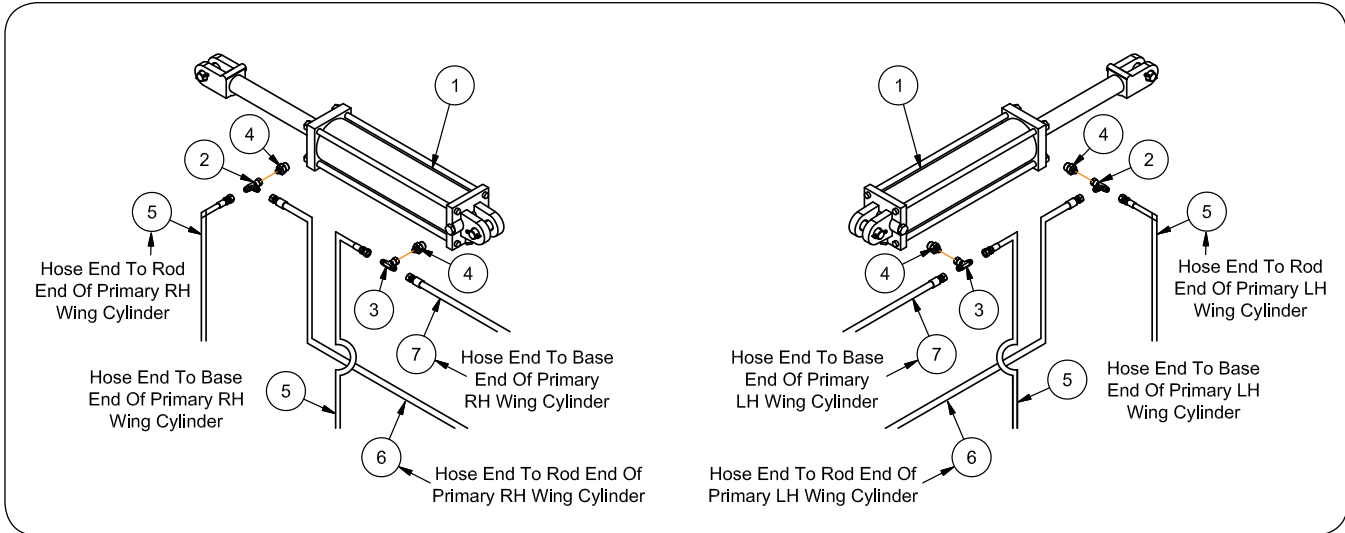

ITEM	PART NUMBER	DESCRIPTION	QTY	NOTES
1	JDP4579	Cylinder 4 1/2" x 20"	2	
2	91465	Tee 9/16-18 JIC Male x 9/16-18 JIC Female x 9/16-18 JIC Male	3	
3	91525	Tee 9/16-18 JIC Male x 9/16-18 JIC Male x 9/16-18 JIC Female	6	
4	98078	Adapter 9/16-18 JIC Male x 7/8-14 O-Ring Male	4	
5	JDP5055	Hydraulic Hose, 1/4" x 66" (9/16-18 JIC Female x 9/16-18 JIC Female)	4	
6	JDP5314	Hydraulic Hose, 3/8" x 152" (9/16-18 JIC Female x 9/16-18 JIC Female)	2	
7	JDP5315	Hydraulic Hose, 3/8" x 168" (9/16-18 JIC Female x 9/16-18 JIC Female)	2	

Coulter Mounting Bracket Components

Please visit www.unverferth.com/parts/ for the most current parts listing.

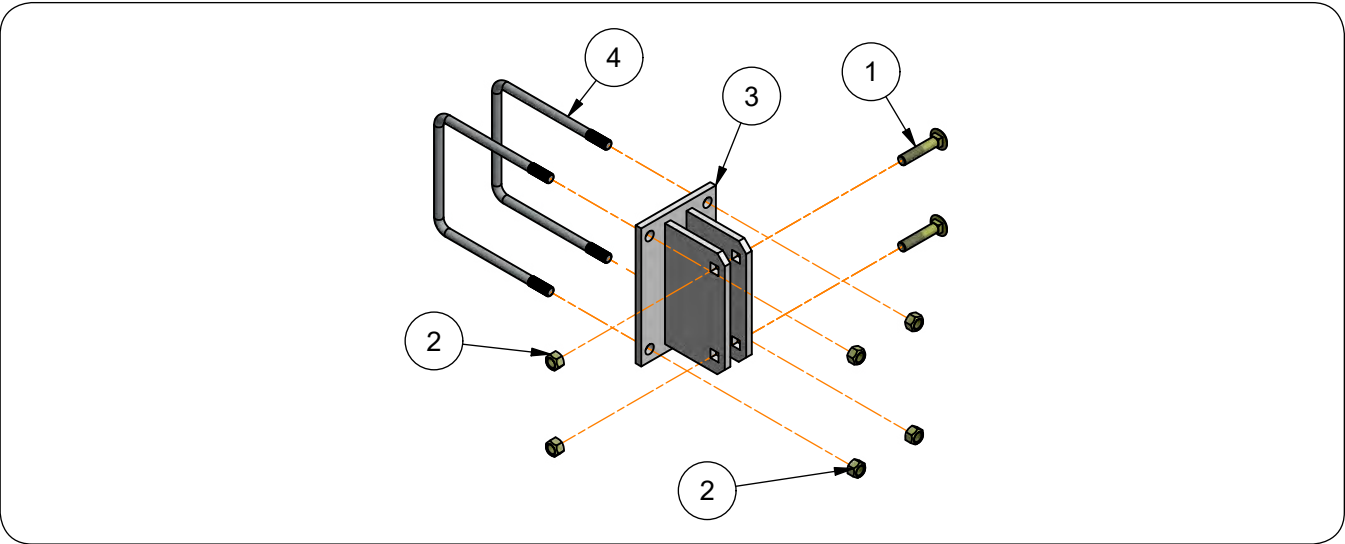

ITEM	PART NUMBER	DESCRIPTION	QTY	NOTES
	JAAM2428	Coulter Mounting Bracket Assembly	-	Includes Items 1-4
1	9388-108	Carriage Bolt, 1/2"-13UNC x 2 1/2" G5	2	
2	9800	Lock Nut/Top, 1/2"-13UNC	6	
3	JAM4780	Flatback Coulter Mounting Bracket	1	
4	JBP3357	U-Bolt, 1/2"-13UNC x 7 1/4", 6 9/16CC	2	

Offset Stagger Bracket & Bracket Extension Components

Please visit www.unverferth.com/parts/ for the most current parts listing.

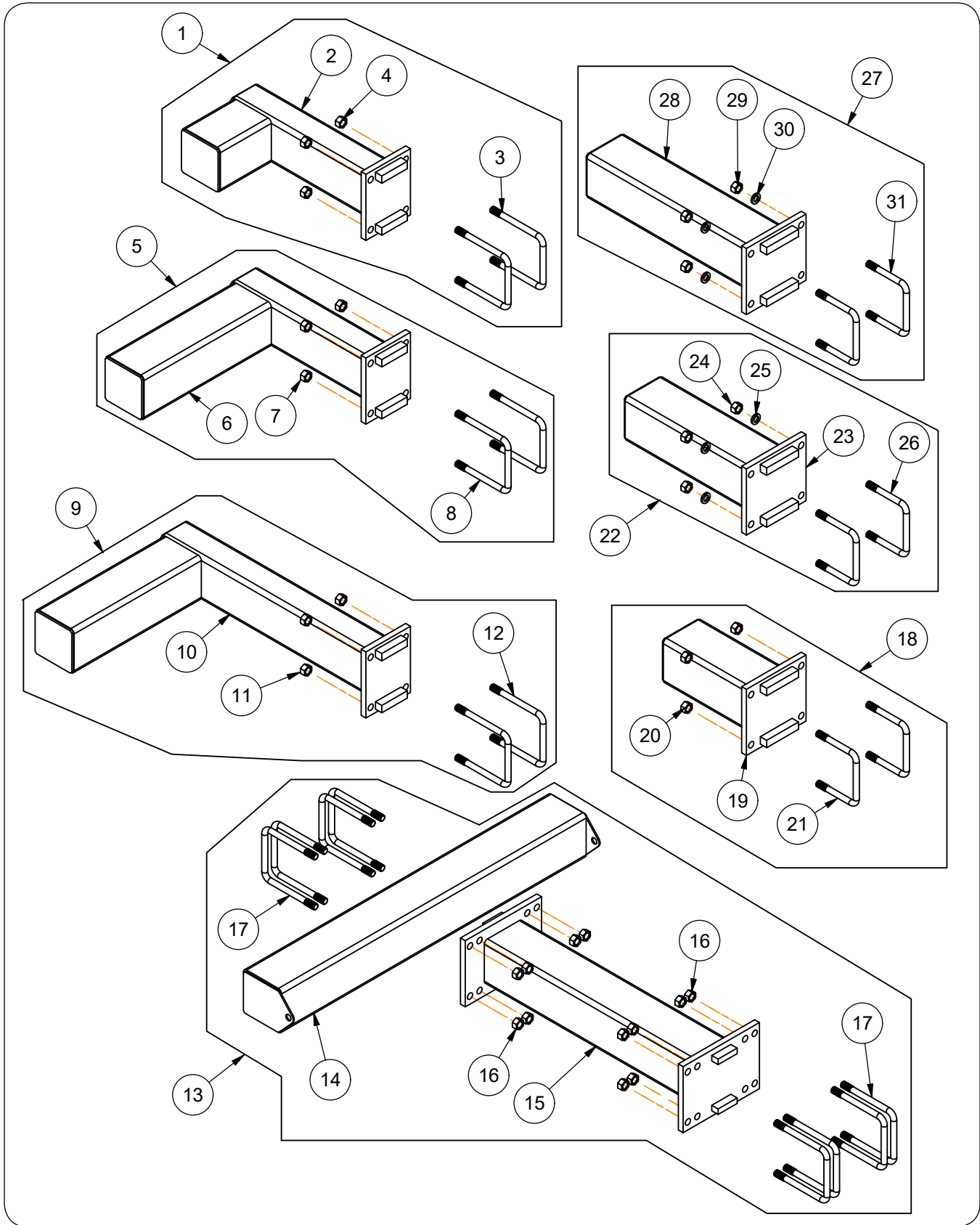

Offset Stagger Bracket & Bracket Extension Components

Please visit www.unverferth.com/parts/ for the most current parts listing.

ITEM	PART NUMBER	DESCRIPTION	QTY	NOTES
1	JAAM2141BB	Offset Stagger Bracket w/Hdw 22" x 8", 6" x 6" Mounting	1	Includes Items 2-4
2	JAM4510BB	Offset Stagger Bracket Weldment 22" x 8"	1	
3	JBP3350	U-Bolt, 3/4"-10UNC x 6"W x 7 11/16"L	2	
4	9802	Lock Nut, 3/4"-10UNC	4	
5	JAAM2123BB	Offset Stagger Bracket w/Hdw 22" x 20", 6" x 6" Mounting	1	Includes Items 6-8
6	JAM4545BB	Offset Stagger Bracket Weldment 22" x 20"	1	
7	9802	Lock Nut, 3/4"-10UNC	4	
8	JBP3350	U-Bolt, 3/4"-10UNC x 6"W x 7 11/16"L	2	
9	JAAM2122BB	Offset Stagger Bracket w/Hdw 33" x 20", 6" x 6" Mounting	1	Includes Items 10-12
10	JAM4509BB	Offset Stagger Bracket Weldment 33" x 20"	1	
11	9802	Lock Nut, 3/4"-10UNC	4	
12	JBP3350	U-Bolt, 3/4"-10UNC x 6"W x 7 11/16"L	2	
13	JAAM2125BB	Extension Double Bracket w/Hdw 40" x 48", 6" x 6" Mounting	1	Includes Items 14-17
14	JAM6160BB	Tube Weldment 48"	1	
15	JAM6161BB	Bracket Extension 35", Double Mounting	1	
16	9802	Lock Nut, 3/4"-10UNC	16	
17	JBP3350	U-Bolt, 3/4"-10UNC x 6"W x 7 11/16"L	8	
18	JAAM2128BB	Bracket Extension 14" w/Hdw, 6" x 6" Mounting	1	Includes Items 19-21
19	JAM4543BB	Bracket Extension 14" Weldment	1	
20	9802	Lock Nut, 3/4"-10UNC	4	
21	JBP3352	U-Bolt 3/4"-10UNC x 6"W x 5 11/16"L	2	
22	JAAM2129BB	Bracket Extension 20" w/Hdw, 6" x 6" Mounting	1	Includes Items 23-26
23	JAM6162BB	Bracket Extension 20" Weldment	1	
24	9394-016	Hex Nut, 3/4"-10UNC	4	
25	9404-033	Lock Washer, 3/4"	4	
26	JBP3352	U-Bolt 3/4"-10UNC x 6"W x 5 11/16"L	2	
27	JAAM2130	Bracket Extension 26" w/Hdw, 6" x 6" Mounting	1	Includes Items 28-31
28	JAM4542	Bracket Extension 26" Weldment	1	
29	9394-016	Hex Nut, 3/4"-10UNC	4	
30	9404-033	Lock Washer, 3/4"	4	
31	JBP3352	U-Bolt 3/4"-10UNC x 6"W x 5 11/16"L	2	

Super 1200 Flex Coulter Hub Assembly Components

Please visit www.unverferth.com/parts/ for the most current parts listing.

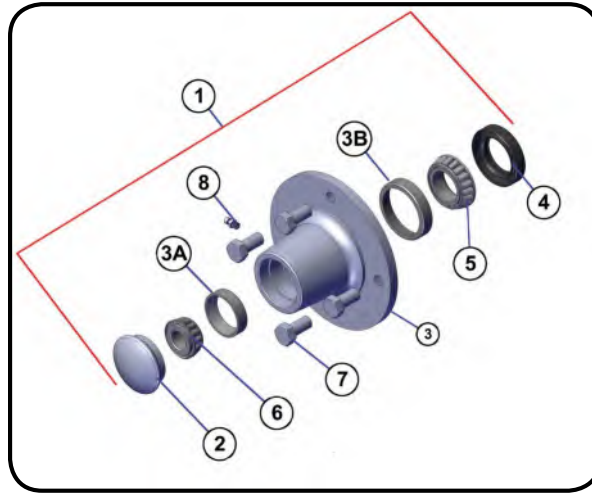

ITEM	PART NUMBER	DESCRIPTION	QTY	NOTES
1	JAP2707	HUB ASSEMBLY, 4 BOLT	1	
2	90024	HUB CAP, 1610	1	
3	JAP2706-1	HUB W/ CUPS, 4 BOLT, 5" BC, 3.62" PILOT, W/ZERK HOLE	1	
3A	9784	BEARING CUP, LM 11910	1	
3B	9345	BEARING CUP, LM 67010	1	
4	JAP2747	GREASE SEAL, 15235TB	1	
5	9165	BEARING CONE, LM 67048	1	
6	9789	BEARING CONE, LM 11949	1	
7	9390-323	HEX CAP SCREW, 1/2"-20UNF X 1", GRADE 5, PLATED	4	
8	91160	Grease Zerk 1/4"-28 STT	1	

Super 1200 Flex Coulter & Post Assembly

ITEM	PART NUMBER	DESCRIPTION	QTY	NOTES
	JAAM2728	COULTER, SUPER 1200, 16, 1R	1	Includes Items 1-7
1	9390-032	Capscrew, 5/16"-18UNC x 1 1/2"	1	
2	9392-182	Roll Pin, 3/8" Dia. x 2 1/2"	1	
3	9807	Lock Nut/Top, 5/16"-18UNC	1	
4	JAM2735	Coulter Shank, 16"	1	
5	JAM2799	Coulter Arm w/Hub & Knee Casting Assembly	1	
6	JBP3205	MACHINERY BUSHING, 2-1/2" OD X 1-3/4" ID, 10GA, PLATED	1	
7	JBP3534	Roll, Pin, 7/32" Dia. x 2 1/2"	1	

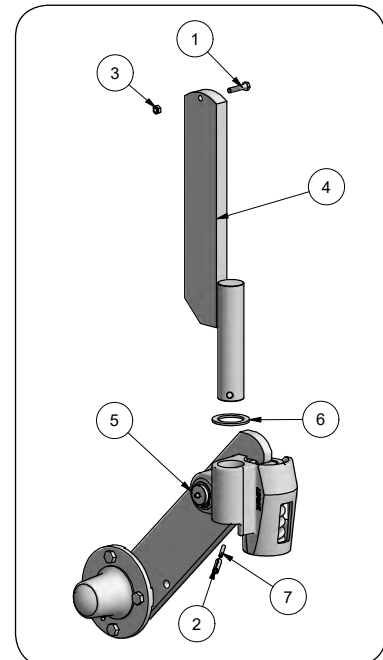

Super 1200 Flex Coultter Assembly Components

Please visit www.unverferth.com/parts/ for the most current parts listing.

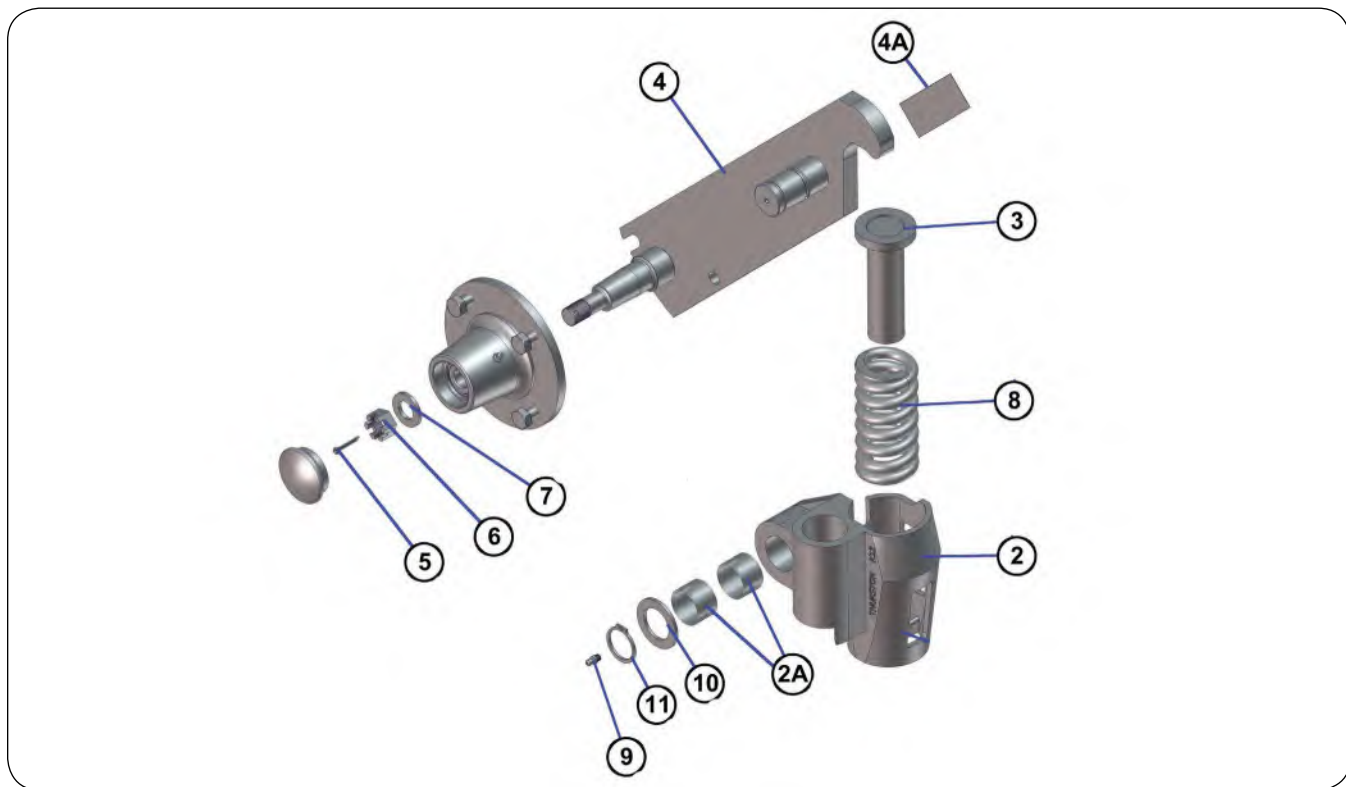

ITEM	PART NUMBER	DESCRIPTION	QTY	NOTE
1	JAM2799	ASSEMBLY, COULTER ARM WITH HUB & KNEE CASTING, HD	1	
2	JAM2743B	CASTING, COULTER KNEE, HD, MACHINED WITH BUSHINGS	1	
2A	JAP2274	BUSHING, 1-17/32" OD X 1-3/8" ID" X 1" OAL	2	
3	JAM2796PL	SPRING CAP & GUIDE, HD COULTER	1	
4	JAM2797	COULTER ARM, HD	1	
4A	JAP2216	DECAL, BLU-JET, SMALL, 1-1/2" X 4"	1	
5	9391-034	PIN, COTTER, 5/32" X 1-1/2"	1	
6	9393-016	NUT, SPINDLE, 3/4"-16	1	
7	91050	WASHER, SPINDLE, 1-1/2" X 13/16" X .134"	1	
8	JAP2881B	SPRING, 2.472" OD X 5.875" OAL, .468 WIRE DIAMETER	1	
9	91160	Grease Zerk 1/4"-28 STT	1	
10	JBP3404	MACHINERY BUSHING, 2-1/8" OD X 1-3/8" ID X 10 GAUGE	1	
11	91575	SNAP RING, 1-3/8" EXTERNAL, 5160-137	1	

SealPro II (JAAM2856) & Blades For 1 1/4" Edge Bent Shank

Please visit www.unverferth.com/parts/ for the most current parts listing.

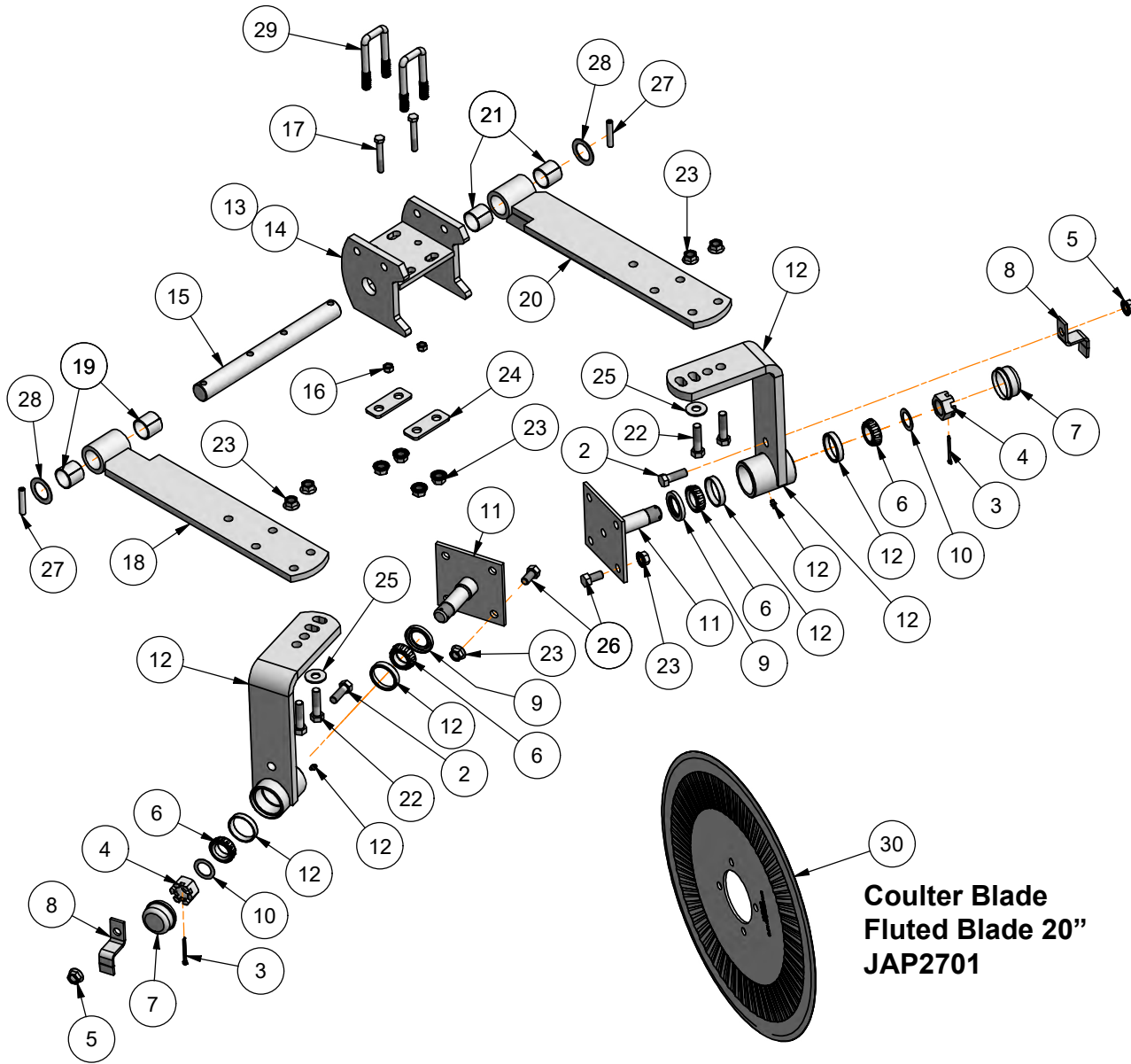

Blade Options



JAM2479
17" Notched Blade



JAP2728
17" Wavy

SealPro II (JAAM2856) & Blades For 1 1/4" Edge Bent Shank

Please visit www.unverferth.com/parts/ for the most current parts listing.

ITEM	PART NUMBER	DESCRIPTION	QTY	NOTES
	JAAM2856	SealPro II, 1 1/4" Edge Bent Shank, 1 Row	-	Includes Items 1-29
1	JAM2481	Sealer Hanger Assembly with Blade Mounting	2	Includes Items 2-12
2	9390-101	Capscrew, 1/2"-13UNC x 1 1/2" G5	1	
3	9391-036	Cotter Pin, 5/32" Dia. x 1 3/4"	1	
4	9393-020	Slotted Nut, 1"-8UNS	1	
5	91267	Flange Nut, 1/2"-13UNC	1	
6	91821	Bearing Cone, 1.0625" Bore	2	
7	92521	Hub Cap	1	
8	JAM2482	Hub Cap Retainer	1	
9	JAP4209	Grease Seal, Double Lip	1	
10	JBP3739	Machinery Bushing, 1" ID	1	
11	JEM3245	Blade Mounting Weldment	1	
12	JEM3246	Sealer Hanger	1	
13	JAM2485	Sealer Mounting Bracket Assembly without Arms	1	Includes Items 14-17
14	JAM2484	Sealer Mounting Bracket	1	
15	JBM3643	Sealer Shaft Pin, 1 1/4" Dia. x 12 1/2"	1	
16	9928	Lock Nut/Top, 3/8"-16UNC	2	
17	9390-061	Capscrew, 3/8"-16UNC x 2 1/2" G5	2	
18	JAM2486	Sealer Arm LH Weldment w/2 Hanger Positions	1	Includes Item #19
19	JAP3115	Self-Lubricated Split Bushing 1.41" OD x 1.25" ID x 1.25	2	
20	JAM2487	Sealer Arm RH Weldment w/2 Hanger Positions	1	Includes Item #121
21	JAP3115	Self-Lubricated Split Bushing 1.41" OD x 1.25" ID x 1.25	2	
22	9390-103	Capscrew, 1/2"-13UNC x 2" G5	4	
23	91267	Flange Nut, 1/2"-13UNC	16	
24	45967B	Tie Plate	2	
25	9405-088	Flat Washer, 1/2" USS	2	
26	9390-099	Capscrew, 1/2"-13UNC x 1" G5	8	
27	9392-180	Roll Pin, 3/8" Dia. x 2"	2	
28	91174	Machinery Bushing, 1 7/8" OD x 1 1/4" ID x 14GA	2	
29	JBP3314	U-Bolt, 1/2"-13UNC x 1 1/4"W x 3 3/4"L	2	
30	JAP2701	Coulter Blade 20" Dia. Fluted, Standard	1	
	JAM2479	Coulter Blade 17" Dia. Notched, Optional	-	
	JAP2728	Coulter Blade 17" Dia. Wavy, Optional	-	

DiscCover Sealer (JAAM2893) For 1 1/4" Edge Bent Shank

Please visit www.unverferth.com/parts/ for the most current parts listing.

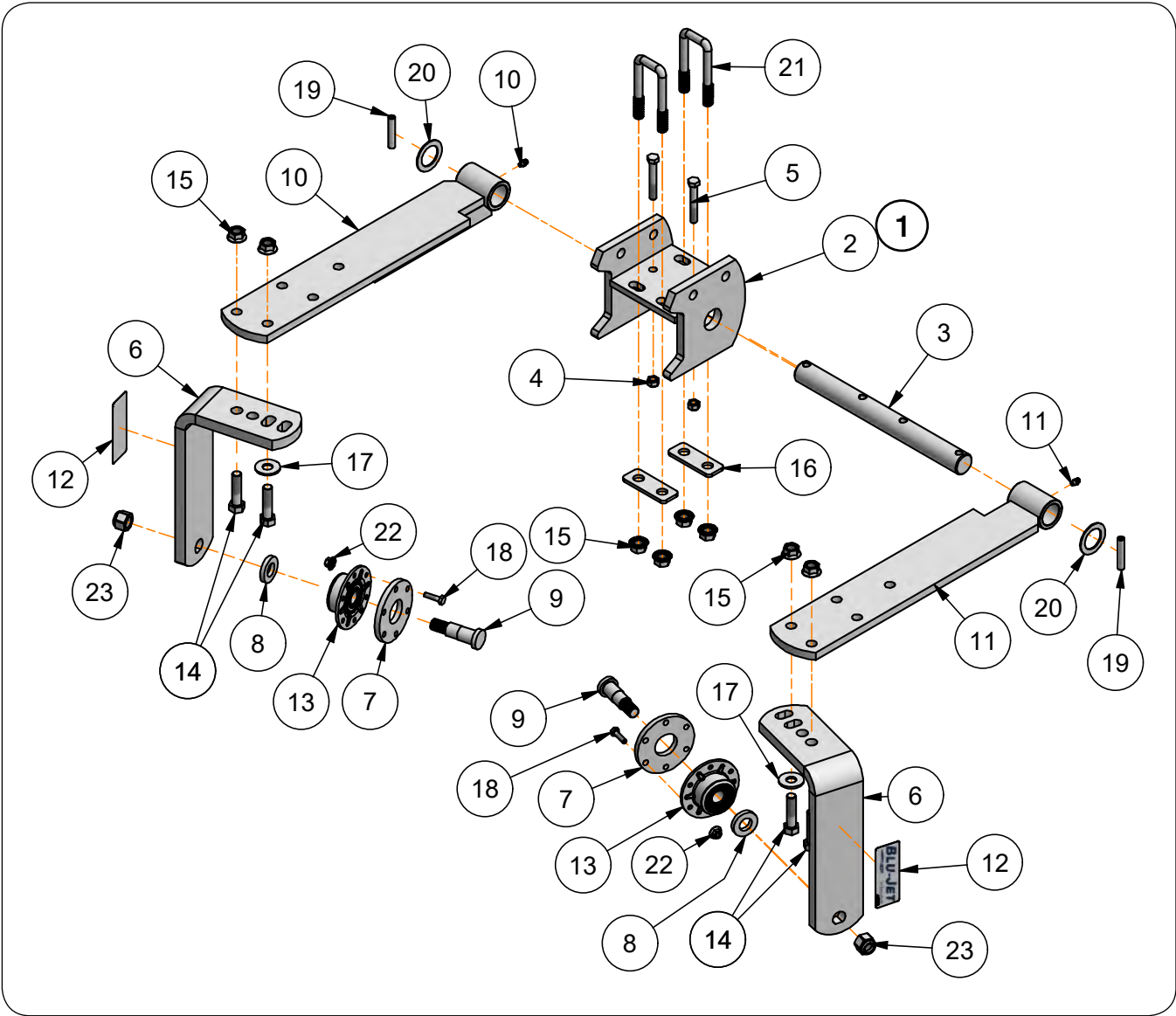

DiscCover Sealer (JAAM2893) For 1 1/4" Edge Bent Shank

Please visit www.unverferth.com/parts/ for the most current parts listing.

ITEM	PART NUMBER	DESCRIPTION	QTY	NOTES	
	JAAM2893	DiscCover Sealer, 1 1/4" Edge Bent Shank, 1 Row	1	Includes Items 1-23	
1	JAM2485	Sealer Mounting Bracket Assembly Without Arms	1	Includes Items 2-5	
	2	JAM2484	Sealer Mounting Bracket	1	
	3	JBM3643	Sealer Shaft Pin, 1 1/4" Dia. x 12 1/2"	1	
	4	9928	Lock Nut/Top, 3/8"-16UNC	2	
	5	9390-061	Capscrew, 3/8"-16UNC x 2 1/2" G5	2	
6	JAM2745	Sealer Hanger Mount	2		
7	44548B	SealPro Blade Spacer	2		
8	JAM2748	Washer, 1 1/2" OD x 25/32" ID x 1/4"	2		
9	44547	SealPro Hub Mounting Bolt, 5/8"-11UNC	2		
10	JAM2750	Sealer Arm LH Weldment, Greaseable, 2 Position	1		
	91160	Grease Zerk 1/4"-28 STT	1		
11	JAM2751	Sealer Arm RH Weldment, Greaseable, 2 Position	1		
	91160	Grease Zerk 1/4"-28 STT	1		
12	JAP2216	Decal, BLU-JET (1 1/2" x 4)	2		
13	JAP4581	Bearing Unit, ADH 7546	2		
14	9390-103	Capscrew, 1/2"-13UNC x 2" G5	4		
15	91267	Flange Nut, 1/2"-13UNC	8		
16	45967B	Tie Plate	2		
17	9405-088	Flat Washer, 1/2" USS	2		
18	9390-005	Capscrew, 1/4"-20UNC x 1" G5	12		
19	91144-207	Spiral Pin, 3/8" Dia. x 2"	2		
20	91174	Machinery Bushing, 1 7/8" OD x 1 1/4" ID x 14GA	2		
21	JBP3314	U-Bolt, 1/2"-13UNC x 1 1/4"W x 3 3/4"L	2		
22	97189	Hex Nut/Large Flange, 1/4"-20UNC	12		
23	9398-019	Elastic Lock Nut, 5/8"-11UNC	2		

Disc Sealer Spring Add-On Kit (JAAM2857) Optional

Please visit www.unverferth.com/parts/ for the most current parts listing.

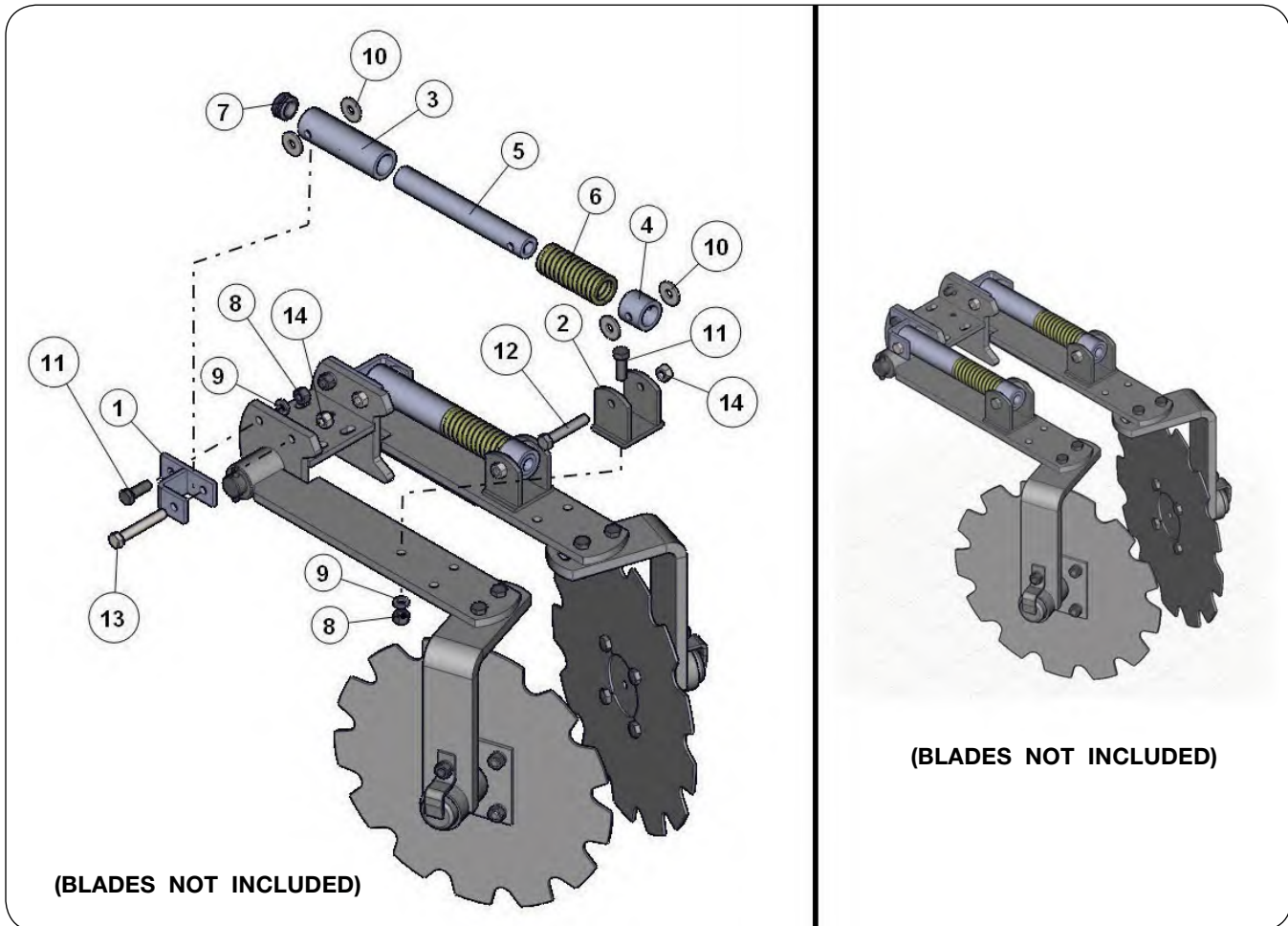

ITEM	PART NUMBER	DESCRIPTION	QTY	NOTES
	JAAM2857	Disc Sealer Spring Add-On Kit Option (Blades Not Included)	-	Includes Items 1-14
1	JAM2488	Upper Sealer Spring Clevis Weldment	2	
2	JAM2489	Lower Clevis Plate	2	
3	JAM2490	Upper Spring Tube	2	
4	JAM2491	Spring Collar Bushing	2	
5	JAM2492	Spring Guide Tube	2	
6	JAP2997	Spring, 1.75" OD x 1.313" ID x 6	2	
7	JAP3116	Tube Plug, 1 3/8" Dia.	2	
8	9394-010	Hex Nut, 1/2"-13UNC	4	
9	9404-025	Lock Washer, 1/2"	4	
10	9405-088	Flat Washer, 1/2" USS	8	
11	9390-101	Capscrew, 1/2"-13UNC x 1 1/2" G5	4	
12	9390-107	Capscrew, 1/2"-13UNC x 3" G5	2	
13	9390-109	Capscrew, 1/2"-13UNC x 3 1/2" G5	2	
14	94981	Lock Nut/Center, 1/2"-13UNC	4	

Sealer Hanger with Blade Mounting (JAM2481)

Please visit www.unverferth.com/parts/ for the most current parts listing.

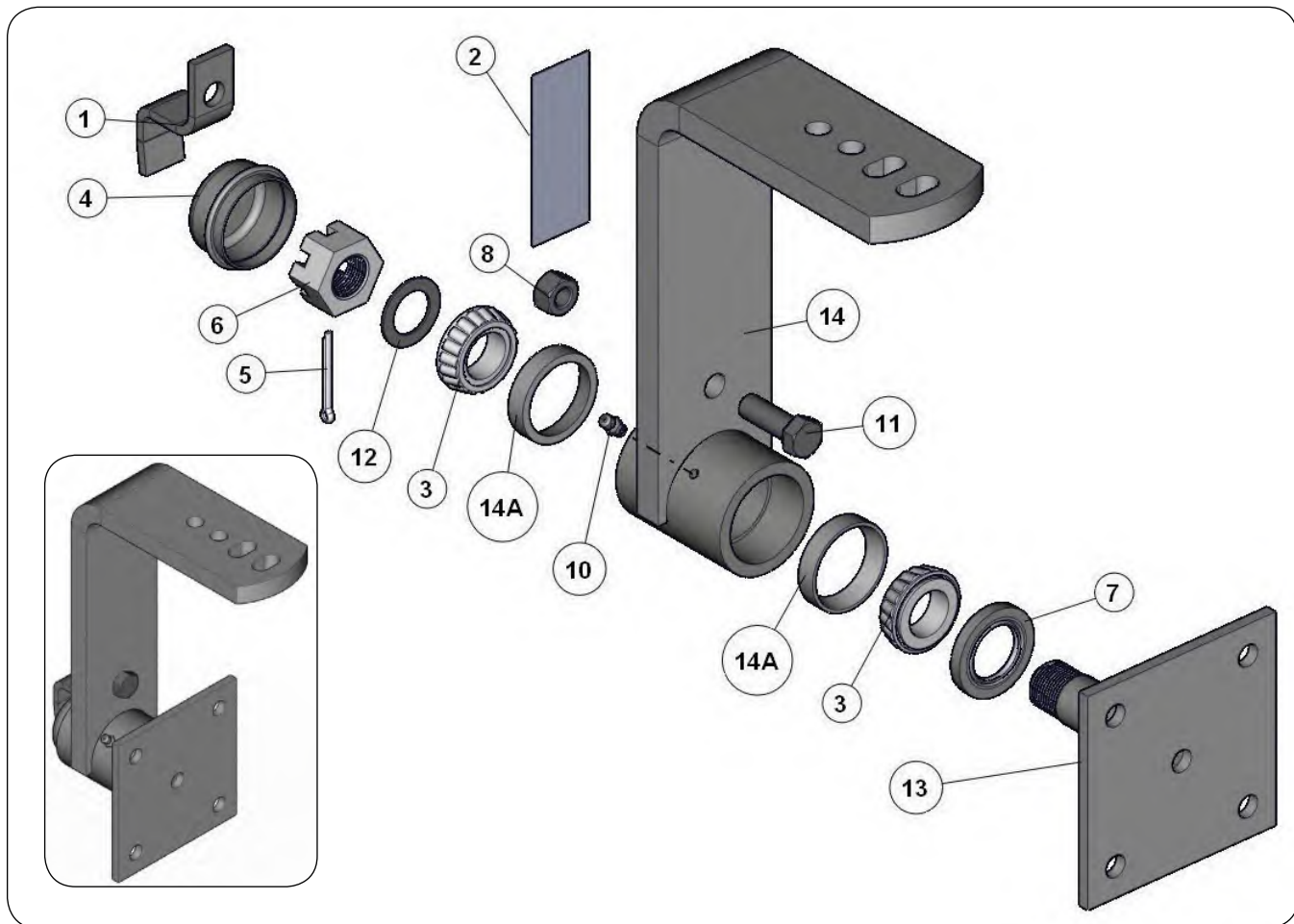

ITEM	PART NUMBER	DESCRIPTION	QTY	NOTES
	JAM2481	Sealer Hanger Assembly with Blade Mounting	-	Includes Items 1-14
1	JAM2482	Hub Cap Retainer	1	
2	JAP2216	Decal, BLU-JET (1 1/2" x 4)	1	
3	91821	Bearing Cone #L44649 (1.0625" Bore)	2	
4	92521	Hub Cap	1	
5	9391-036	Cotter Pin, 5/32" Dia. x 1 3/4"	1	
6	9393-020	Slotted Nut, 1"-14UNS	1	
7	JAP4209	Grease Seal , Double Lip (CR12428)	1	
8	91267	Flange Nut, 1/2"-13UNC	1	
9	N/A	N/A	N/A	
10	91160	Grease Zerk 1/4"-28 STT	1	
11	9390-101	Capscrew, 1/2"-13UNC x 1 1/2" G5	1	
12	JBP3739	Machinery Bushing 1 1/2" OD x 1" ID x 18GA	1	
13	JEM3245	Blade Mounting Weldment	1	
14	JEM3246	Sealer Hanger Weldment with Cups	1	Includes Item 14A
14A	92522	Bearing Cup #L44610 (1.98" OD)	2	

Row Clamp w/EdgeBent Shank & Coulter Mount (JAAM2132)

Please visit www.unverferth.com/parts/ for the most current parts listing.

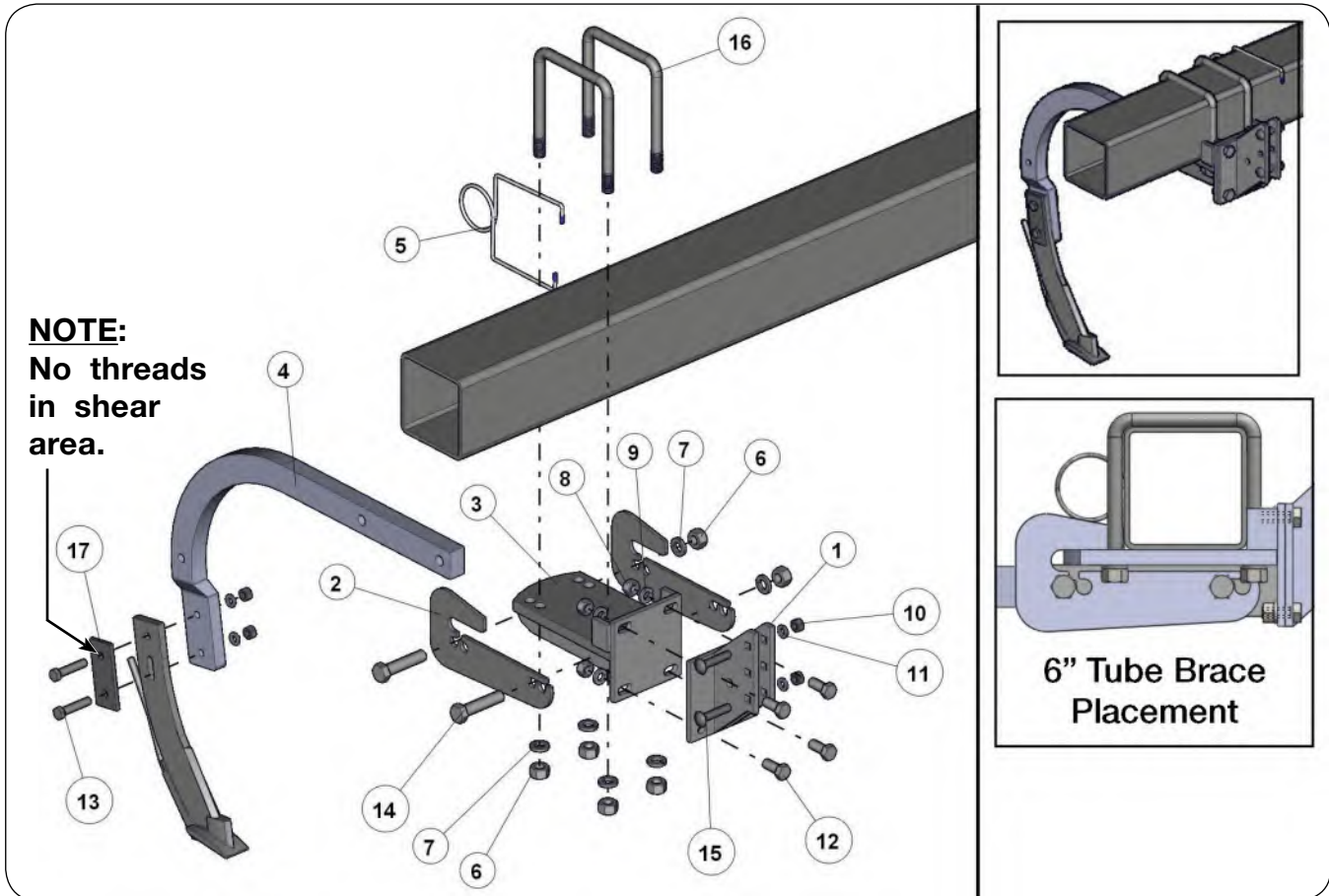

Row Clamp w/EdgeBent Shank & Coulter Mount (JAAM2132)

Please visit www.unverferth.com/parts/ for the most current parts listing.

ITEM	PART NUMBER	DESCRIPTION	QTY	NOTES
	JAAM2132	Row Clamp with EdgeBent Shank & Coulter Mount 6" x 6"	-	Includes Items 1-17
1	JAM2699	Spring Flatback Bracket	1	
2	JAM4891	Anti-Rotation, EdgeBent Shank Brace	2	
3	JAM4893	Rigid Mount Bracket	1	
4	JAP2125	1 1/4" x 2" EdgeBent Shank	1	
5	JAP2283-1	Hose Retainer, 6" x 6"	1	
6	9394-016	Hex Nut, 3/4"-10UNC	6	
7	9404-033	Lock Washer, 3/4"	6	
8	9394-014	Hex Nut, 5/8"-11UNC	4	
9	9404-029	Lock Washer, 5/8"	4	
10	9394-010	Hex Nut, 1/2"-13UNC	4	
11	9404-025	Lock Washer, 1/2"	4	
12	9390-122	Capscrew, 5/8"-11UNC x 1 1/2" G5	4	
13	9390-105	Capscrew, 1/2"-13UNC x 2 1/2" G5	2	
14	9390-151	Capscrew, 3/4"-10UNC x 3 1/2" G5	2	
15	9388-108	Carriage Bolt, 1/2"-13UNC x 2 1/2" G5	2	
16	JBP3350	U-Bolt, 3/4"-10UNC x 6"W x 7 11/16"L	2	
17	JCM2311	Knife Washer 2" x 4 3/4"	1	

Shank Assembly 1 1/4" EdgeBent SCS Less Coulter (JAAM2134)

Please visit www.unverferth.com/parts/ for the most current parts listing.

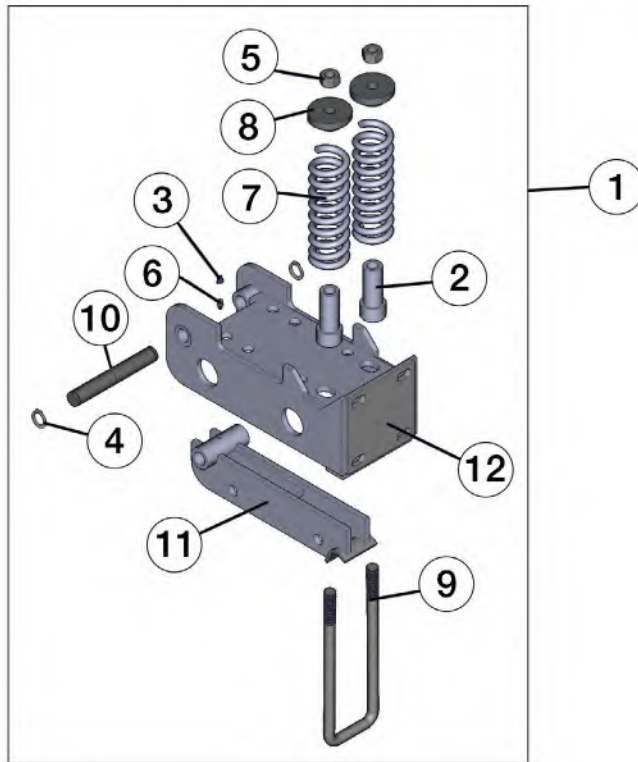
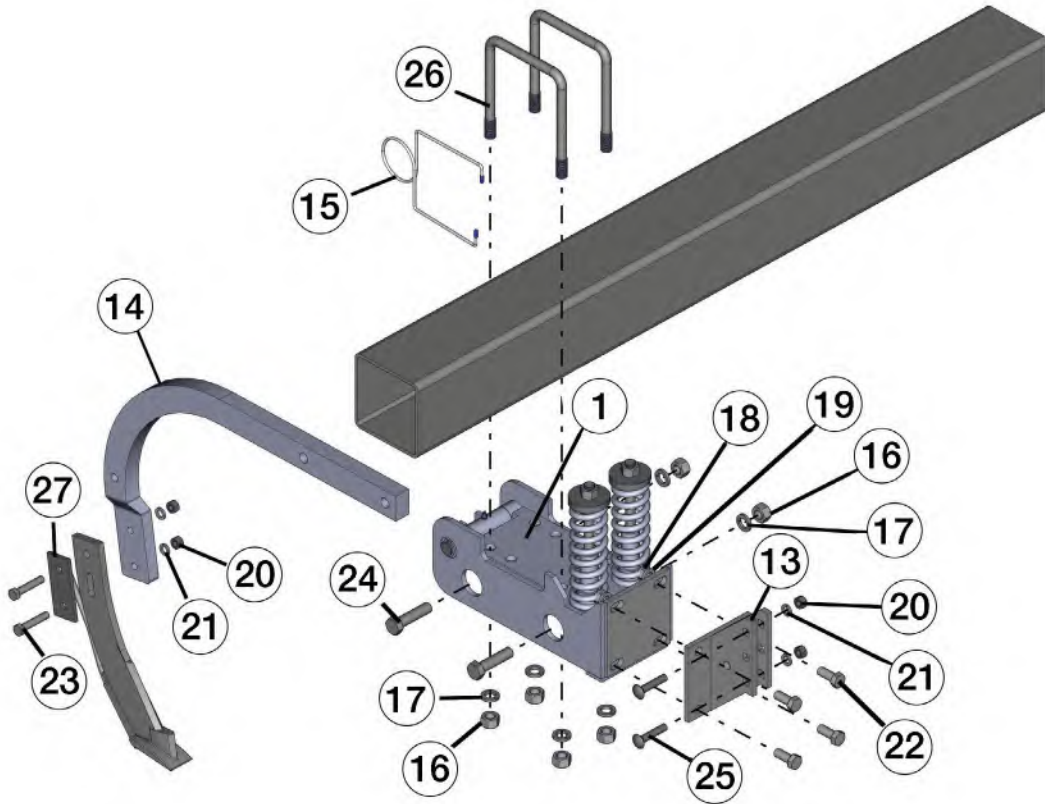

Shank Assembly 1 1/4" EdgeBent SCS Less Coulter (JAAM2134)

Please visit www.unverferth.com/parts/ for the most current parts listing.

ITEM	PART NUMBER	DESCRIPTION	QTY	NOTES
1	44822B	Spring Bundle Assembly, EdgeBent Shank	1	Includes Items 2-12
2	JAM2156	Spring Sleeve Weldment	2	
3	9006849	Grease Zerk CapPlug	1	
4	91192	Retaining Ring, 1"	2	
5	96732	Lock Nut/Center, 3/4"-10UNC	2	
6	91160	Grease Zerk 1/4"-28 STT	1	
7	JBP3104	Compression Spring 2.64" Dia. x 8.625"	2	
8	JBP3105-1	Spring Plug, Flash Removed	2	
9	JBP3106	U-Bolt 3/4"-10UNC x 11 3/4, 3 7/8"CC	1	
10	JEM2959	Pin, 1" Dia. x 7 1/4"	1	
11	JEM2977	Insert Weldment, EdgeBent Shank	1	
12	JEM2978	Spring Bundle Base Weldment	1	
13	JAM2699	Spring Flatback Bracket	1	
14	JAP2125	1 1/4" x 2" EdgeBent Shank	1	
15	JAP2283-1	Hose Retainer, 6" x 6"	1	
16	9394-016	Hex Nut, 3/4"-10UNC	6	
17	9404-033	Lock Washer, 3/4"	6	
18	9394-014	Hex Nut, 5/8"-11UNC	4	
19	9404-029	Lock Washer, 5/8"	4	
20	9394-010	Hex Nut, 1/2"-13UNC	4	
21	9404-025	Lock Washer, 1/2"	4	
22	9390-122	Capscrew, 5/8"-11UNC x 1 1/2" G5	4	
23	9390-105	Capscrew, 1/2"-13UNC x 2 1/2" G5	2	
24	9390-149	Capscrew, 3/4"-10UNC x 3" G5	2	
25	9388-108	Carriage Bolt, 1/2"-13UNC x 2 1/2" G5	2	
26	JBP3350	U-Bolt, 3/4"-10UNC x 6"W x 7 11/16"L	2	
27	JCM2311	Knife Washer 2" x 4 3/4"	1	

Row Clamp, 1 1/4" EdgeBent MaxPac w/Shank & Coulter Mount

Please visit www.unverferth.com/parts/ for the most current parts listing.

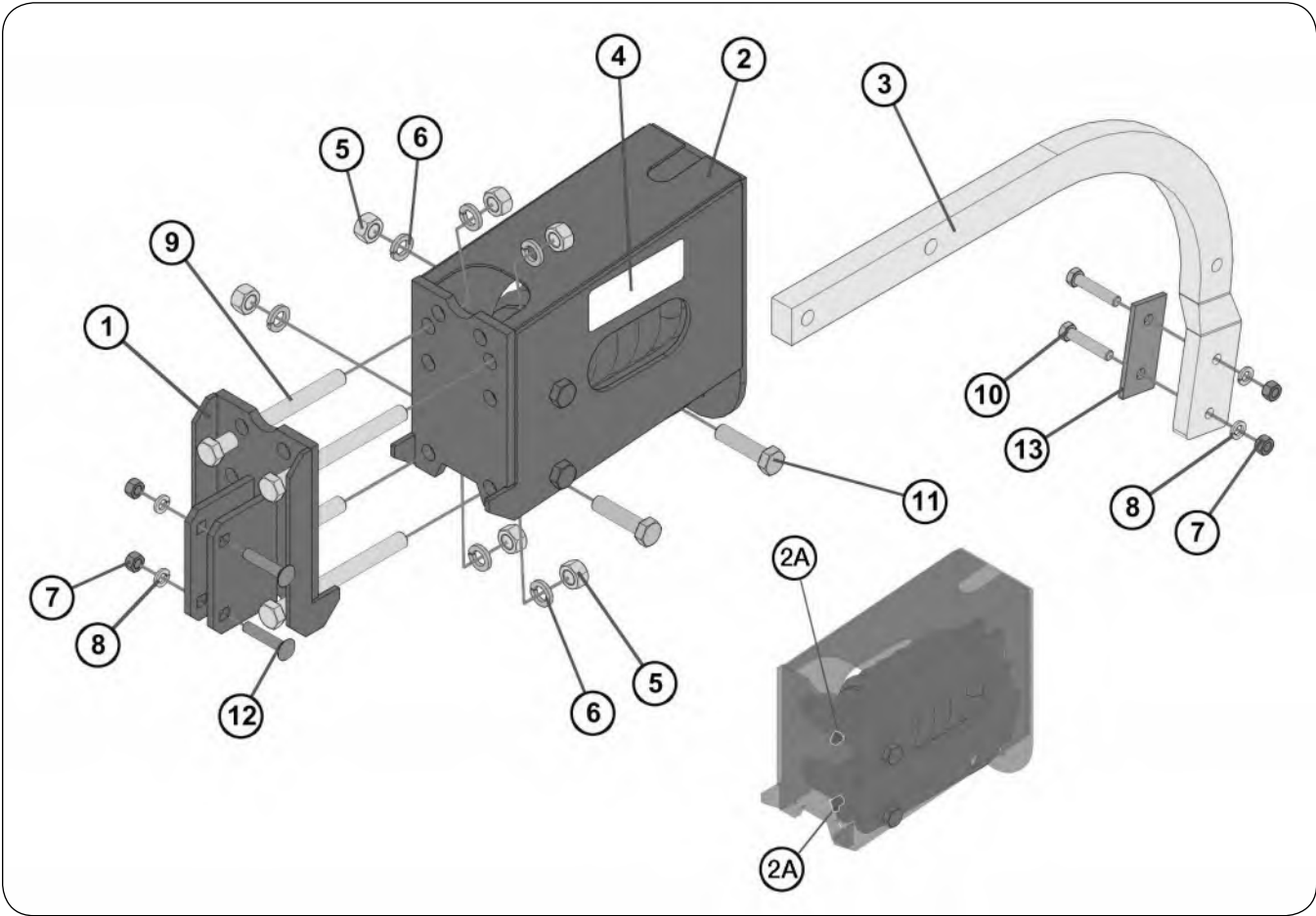

ITEM	PART NUMBER	DESCRIPTION	QTY	NOTES
	JAAM2135	Row Clamp, 1 1/4" EdgeBent MaxPac w/Shank & Coulter Mount	-	Includes Items 1-13
1	JAM2262	Backing Plate, Row Mount with Coulter Mount, AR700	1	
2	JAM2264	AR700 MaxPac Row Unit Assembly	1	Includes Item 2A
2A	93415	Grease Zerk 90°	2	
3	JAP2125	1 1/4" x 2" EdgeBent Shank	1	
4	JAP2976	Decal, MaxPac AR700 (2 1/4" x 6")	1	
5	9394-016	Hex Nut, 3/4"-10UNC	6	
6	9404-033	Lock Washer, 3/4"	6	
7	9394-010	Hex Nut, 1/2"-13UNC	4	
8	9404-025	Lock Washer, 1/2"	4	
9	9390-161	Capscrew, 3/4"-10UNC x 8" G5	4	
10	9390-105	Capscrew, 1/2"-13UNC x 2 1/2" G5	2	
11	9390-149	Capscrew, 3/4"-10UNC x 3" G5	2	
12	9388-108	Carriage Bolt, 1/2"-13UNC x 2 1/2" G5	2	
13	JCM2311	Knife Washer 2" x 4 3/4"	1	

MaxPac Basket Mount Arm Components (JAAM2623)

Please visit www.unverferth.com/parts/ for the most current parts listing.

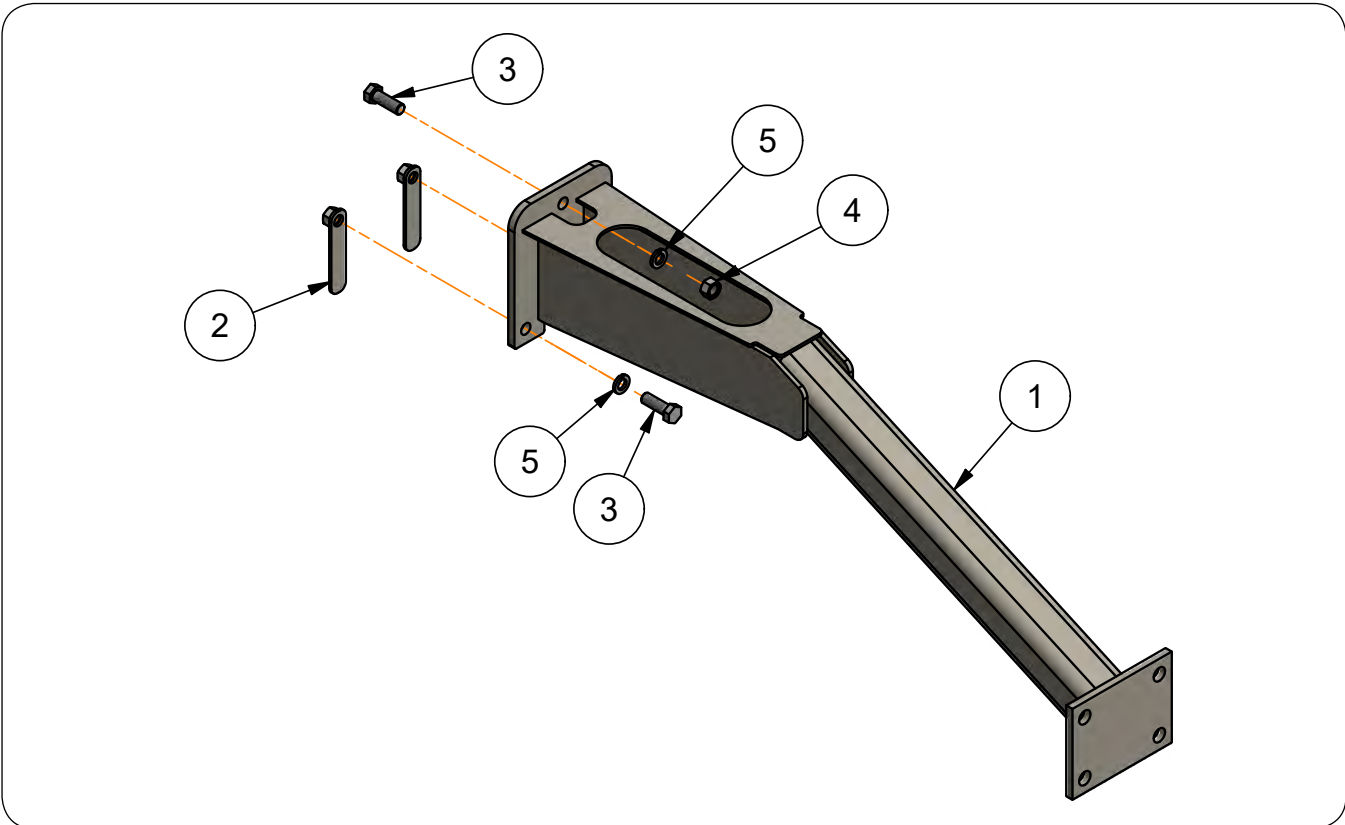

ITEM	PART NUMBER	DESCRIPTION	QTY	NOTES
	JAAM2623	MaxPac Basket Mount (AR700)	1	Includes Items 1-5
1	JAM2271	MaxPac Basket Mount Weldment	1	
2	JAM2273	Nut Plate Weldment	2	
3	9390-101	Capscrew, 1/2"-13UNC x 1 1/2" G5	3	
4	9394-010	Hex Nut, 1/2"-13UNC	1	
5	9404-025	Lock Washer, 1/2"	3	

MaxPac Mount with Edgebent Shank Bundle #43599

Please visit www.unverferth.com/parts/ for the most current parts listing.

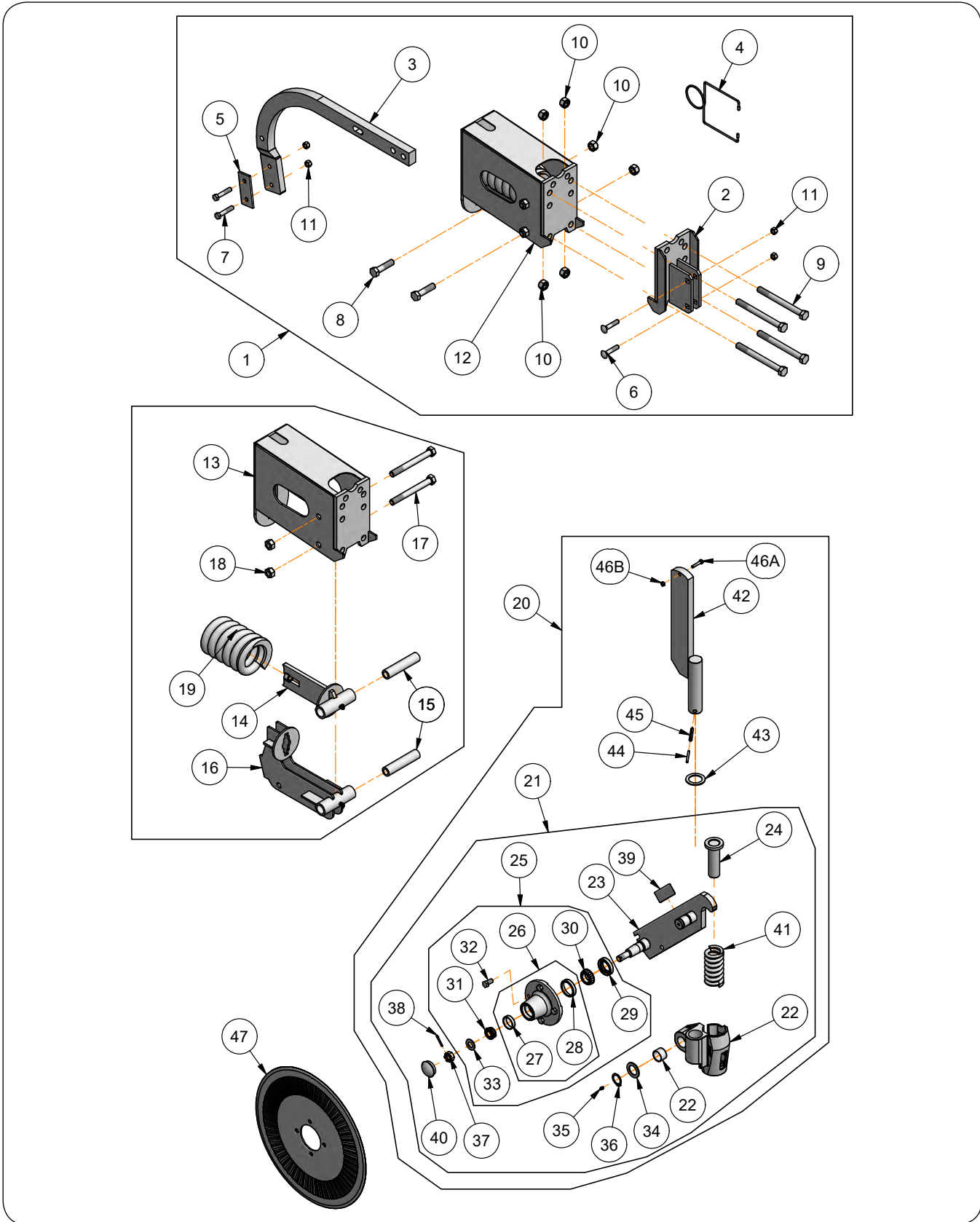

MaxPac Mount with Edgebent Shank Bundle #43599

Please visit www.unverferth.com/parts/ for the most current parts listing.

ITEM	PART NUMBER	DESCRIPTION	QTY	NOTES
	43599	Max Pac Shank Mount w/ 1 1/4" Edge-Bent Shank Assembly	-	Includes Items 1-47
1	44429	Max Pac Shank Assembly	1	Includes Items 2-19
2	JAM2262	Backing Plate, Row Mount with Coulter Mount, AR700	1	
3	JAP2125	1 1/4" x 2" EdgeBent Shank	1	
4	JAP2283-1	Hose Retainer with Caps	1	
5	JCM2311	Knife Washer 2" x 4 3/4"	1	
6	9388-108	Carriage Bolt, 1/2"-13UNC x 2 1/2" G5	2	
7	9390-105	Capscrew, 1/2"-13UNC x 2 1/2" G5	2	
8	9390-149	Capscrew, 3/4"-10UNC x 3" G5	2	
9	9390-161	Capscrew, 3/4"-10UNC x 8" G5	4	
10	9802	Lock Nut/Top, 3/4"-10UNC	6	
11	9800	Lock Nut/Top, 1/2"-13UNC	4	
12	JAM2264	AR700 MaxPac Row Unit Assembly	1	Includes Items 13-19
13	JEM4619	SCS Row Mount Weldment	1	
14	JEM4626	Spring Retainer Weldment	1	
15	JEM4627	Spacer Tube	2	
16	JEM4633	Shank Holder Weldment	1	
17	9390-159	Capscrew, 3/4"-10UNC x 7" G5	2	
18	96732	Lock Nut/Center, 3/4"-10UNC	2	
19	JAP2970-1	Compression Spring	1	
20	JAAM2728	Coulter Assembly, Super 1200	1	Includes Items 21-46
21	JAM2799	Coulter Arm w/Hub & Knee Assembly	1	Includes Items 22-41
22	JAM2743B	Coulter Knee w/Bushings	1	
23	JAM2797	Coulter Arm Weldment w/Decal		Includes Item #39
24	JAM2796PL	Coulter Spring Cap & Guide	1	
25	JAP2777	Hub Assembly	1	
26	JAP2706-1	Hub Subassembly with Cups	1	
27	9784	Outer Bearing Cup 1.780" Dia. #LM11910	1	
28	9345	Inner Bearing Cup 2.328" Dia. #LM67010	1	
29	JAP2747	Grease Seal, Double Lip	1	
30	9165	Bearing Cone 1.2500" Bore #LM67048	1	
31	9789	Bearing Cone #LM11949	1	
32	9390-323	Capscrew, 1/2"-20UNF x 1" G5	4	
33	9405-103	Flat Washer, 3/4" SAE	1	
34	JBP3404	Machinery Bushing, 2 1/8" OD x 1 3/8" ID x 10GA	1	
35	91160	Grease Zerk	1	
36	91575	Retaining Ring 1 3/8" Dia.	1	
37	9393-016	Slotted Nut 3/4"-16UNF	1	
38	9391-034	Cotter Pin 5/32" Dia. x 1 1/4"	1	
39	JAP2216	Decal, Blu-Jet Logo	1	
40	90024	Hub Cap	1	
41	JAP2881B	Compression Spring	1	
42	JAM2735	Coulter Shank, 16"	1	
43	JBP3205	Machinery Bushing, 2 1/2" OD x 1 3/4" ID x 10GA	1	
44	JBP3534	Roll Pin, 7/32" Dia. x 2 1/2"	1	
45	9392-182	Roll Pin, 3/8" Dia. x 2 1/2"	1	
46A	9390-032	Capscrew, 5/16"-18UNC x 1 1/2" G5	1	
46B	9807	Lock Nut/Top, 5/16"-18UNC	1	
47	JAP2701	Coulter Blade 20", Fluted	1	

Coulter Bracket Extension 9 7/8" Kit (JAAM2637)

Please visit www.unverferth.com/parts/ for the most current parts listing.

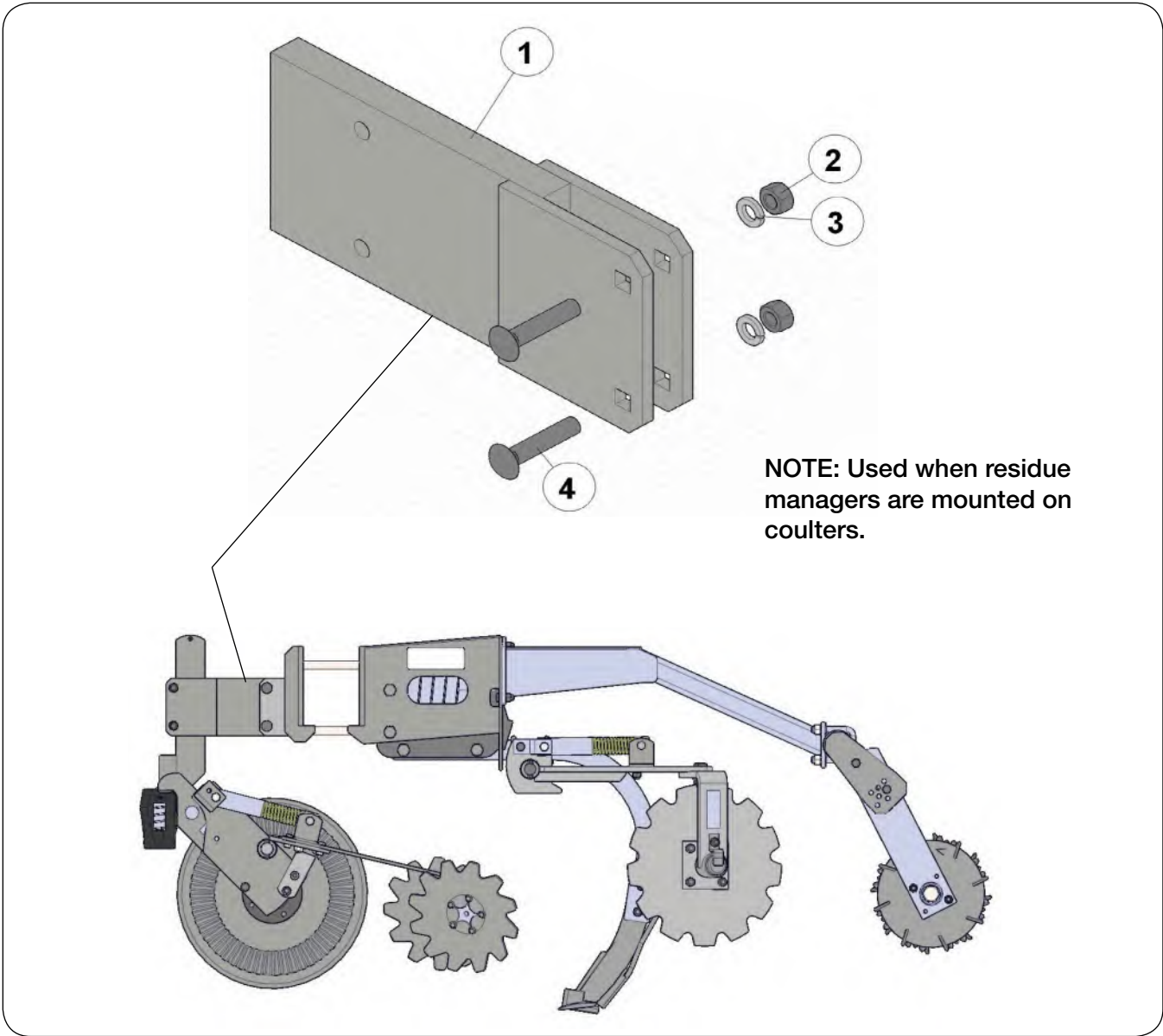

ITEM	PART NUMBER	DESCRIPTION	QTY	NOTES
	JAAM2637	Coulter Bracket Extension 9 7/8" Kit, 1 Row	-	Includes Items 1-4
1	JAM2266	Coulter Shank Bracket Extension 9 7/8" Weldment	1	
2	9394-010	Hex Nut, 1/2"-13UNC	2	
3	9404-025	Lock Washer, 1/2"	2	
4	9388-108	Carriage Bolt, 1/2"-13UNC x 2 1/2" G5	2	

Coulter Bracket Extension 16 7/8" Kit (JAAM2852)

Please visit www.unverferth.com/parts/ for the most current parts listing.

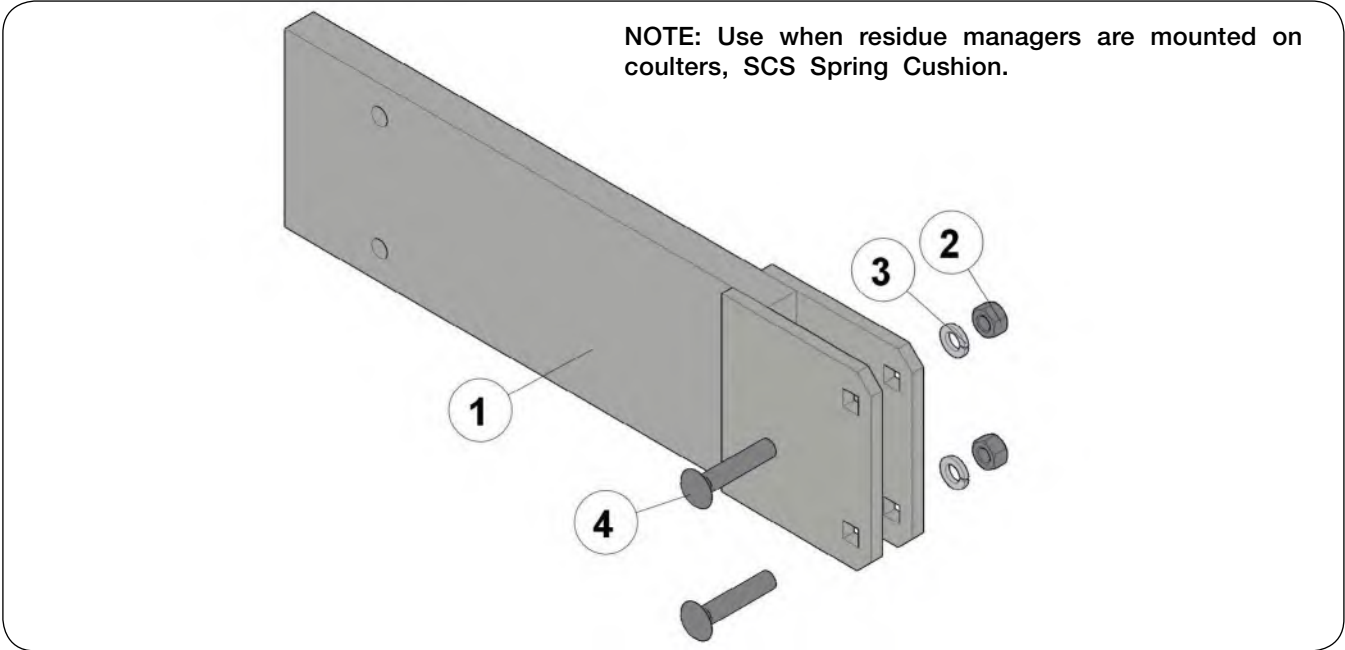

ITEM	PART NUMBER	DESCRIPTION	QTY	NOTES
	JAAM2852	Coulter Bracket Extension 16 7/8" Kit, 1 Row	-	Includes Items 1-4
1	JAM2268	Coulter Shank Bracket Extension 16 7/8" Weldment	1	
2	9394-010	Hex Nut, 1/2"-13UNC	2	
3	9404-025	Lock Washer, 1/2"	2	
4	9388-108	Carriage Bolt, 1/2"-13UNC x 2 1/2" G5	2	

Torsion Arm Basket (Short Arms) Components

Please visit www.unverferth.com/parts/ for the most current parts listing.

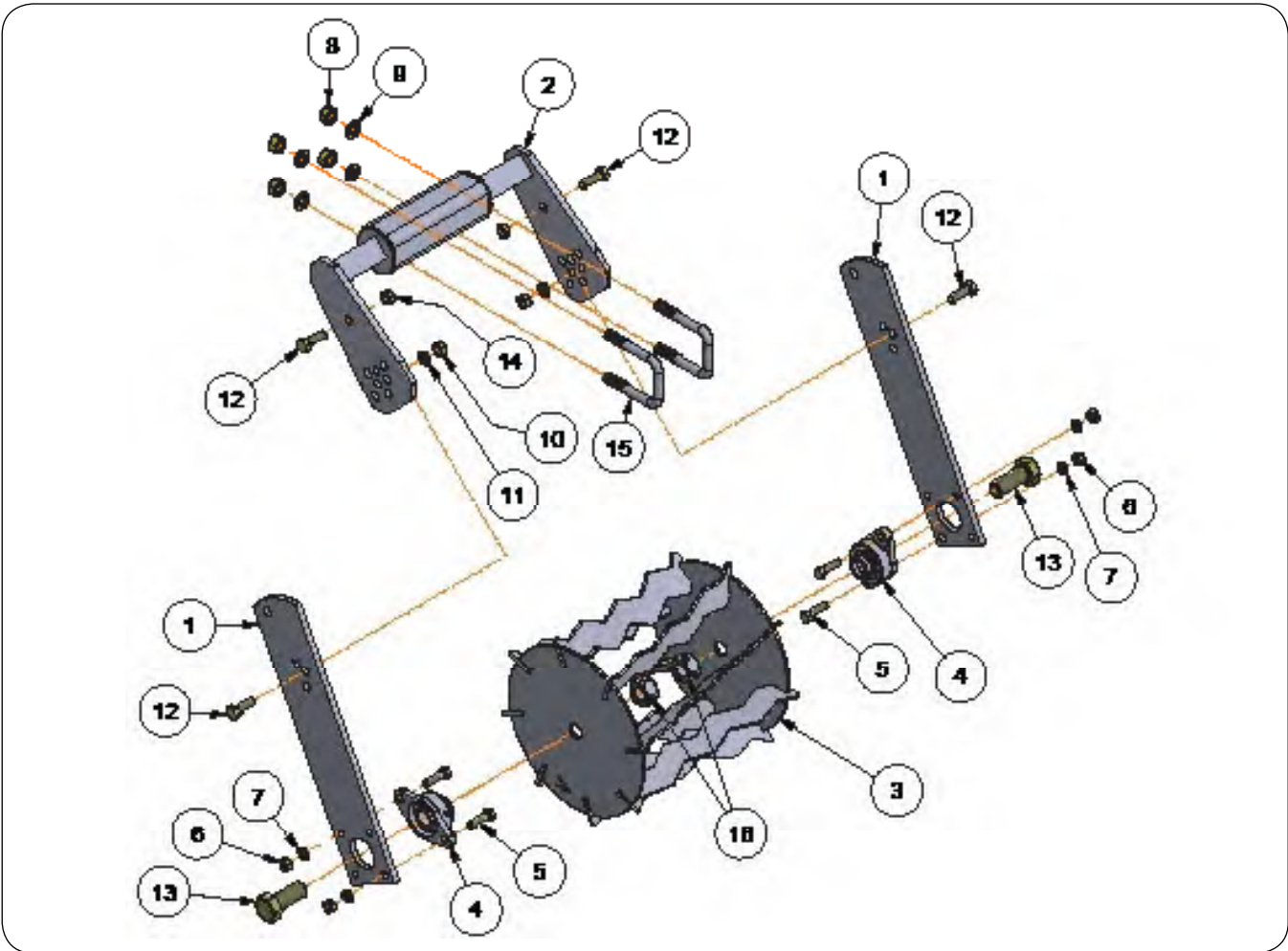

ITEM	PART NUMBER	DESCRIPTION	QTY	NOTES
	J70210641	Torsion Arm & 12 3/4" Basket Assembly, Short	1	Includes Items 1-16
1	JAM2269	Strip-Till Basket Mount, Short (18 3/4")	2	
2	JAM7568	Strip-Till Torsion Spring Assembly	1	
3	JAM7615	Strip-Till Basket, 12 3/4"	1	
4	JAP2144	Bearing HCFT205-16	2	
5	9390-080	Capscrew, 7/16"-14UNC x 1 1/2", G5	4	
6	9394-008	Hex Nut, 7/16"-14UNC	4	
7	9404-023	Lock Washer, 7/16"	4	
8	9394-014	Hex Nut, 5/8"-11UNC	4	
9	9404-029	Lock Washer, 5/8"	4	
10	9394-010	Hex Nut, 1/2"-13UNC	2	
11	9404-025	Lock Washer, 1/2"	2	
12	9390-101	Capscrew, 1/2"-13UNC x 1 1/2" G5	4	
13	9390-185	Capscrew, 1"-8UNC x 2 1/2", G5	2	
14	9800	Lock Nut/Center, 1/2"-13UNC	2	
15	JBP3300	U-Bolt, 5/8"-11UNC x 2 1/2" x 4	2	
16	92199	Hex Lock Nut, 1"-8UNC, Reversible	2	

Torsion Arm/Rigid Basket Mounting Brackets
Rigid Fertilizer Rows - 6" x 6" - Bundle #J70210592
Rigid Fertilizer Rows - 4" x 6" - Bundle #J70210591

Please visit www.unverferth.com/parts/ for the most current parts listing.

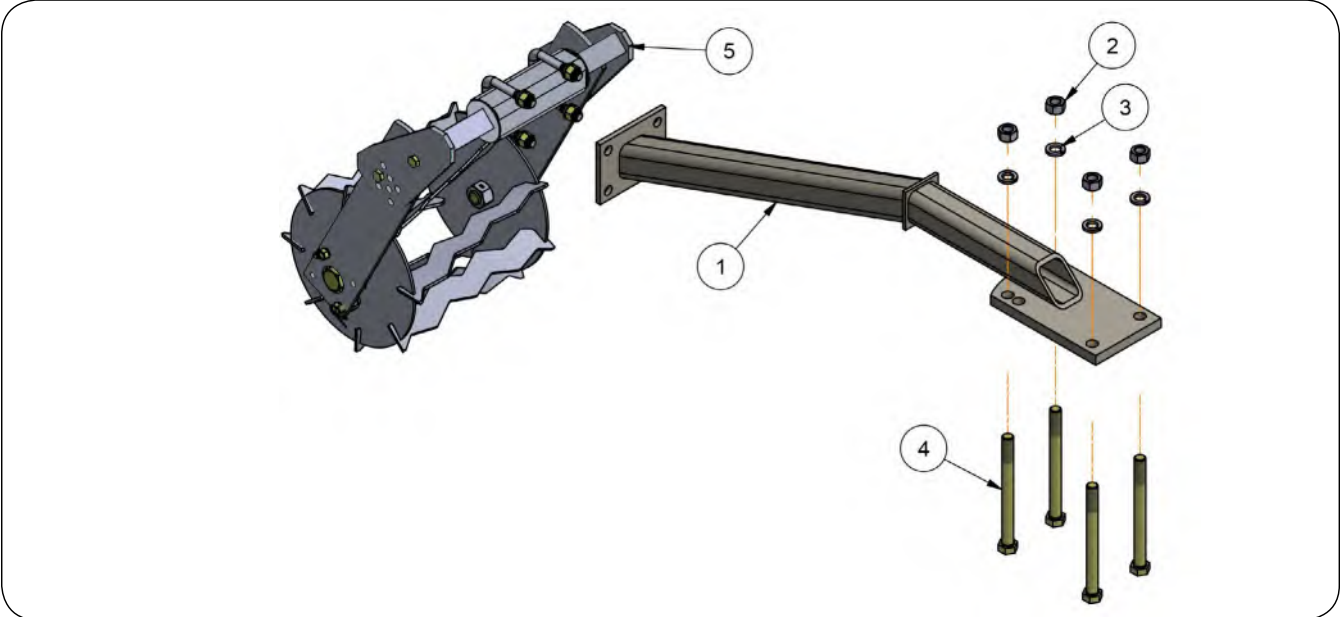

ITEM	PART NUMBER	DESCRIPTION	QTY	NOTES
	J70210592	Rigid Torsion Arm/Basket for 6x6 Mounting	1	Includes Items 1-5
	J70210591	Rigid Torsion Arm/Basket for 4x6 Mounting	1	Includes Items 1-5
1	JAM2272	Rigid Basket Mount Weldment	1	
2	9394-016	Hex Nut, 3/4"-10UNC	4	
3	9404-033	Lock Washer, 3/4"	4	
4	9390-448	Capscrew, 3/4"-10UNC x 8 1/2" G5	4	For 6x6 Mounting
	9390-158	Capscrew, 3/4"-10UNC x 6 1/2" G5	4	For 4x6 Mounting
5	J70210641	Torsion Arm & 12 3/4" Basket Assembly, Short	1	

NOTE:
Rigid row units require Bundle J70210641 with (1) JAM2269 shortened arms.

Basket Flat Mount with Hardware
6" x 6" Mounting - Bundle #JAAM2630
4" x 6" Mounting - Bundle #JAAM2722

Please visit www.unverferth.com/parts/ for the most current parts listing.

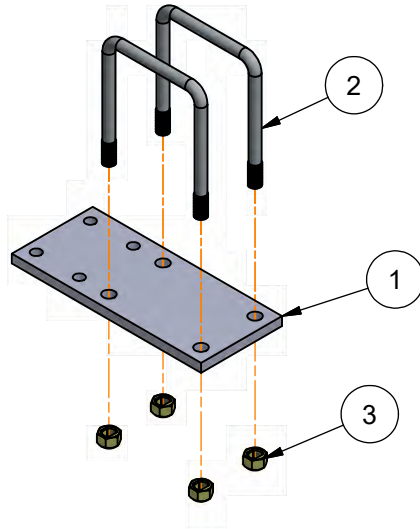

ITEM	PART NUMBER	DESCRIPTION	QTY	NOTES
	JAAM2630	Basket Flat Mount w/Hardware, For 6x6 Mounting	1	Includes Items 1-3
	JAAM2722	Basket Flat Mount w/Hardware, For 4x6 Mounting	1	Includes Items 1-3
1	JAM7637	Basket Mount Plate	1	
2	JBP3350	U-Bolt, 3/4"-10UNC x 6"W x 7 11/16"L	2	For 6x6 Mounting
	JBP3208	U-Bolt, 3/4"-10UNC x 6"W x 5 11/16"L	2	For 4x6 Mounting
3	9802	Lock Nut/Top, 3/4"-10UNC	4	

Residue Manager Blade Mounting Assembly (JAM7670)

Please visit www.unverferth.com/parts/ for the most current parts listing.

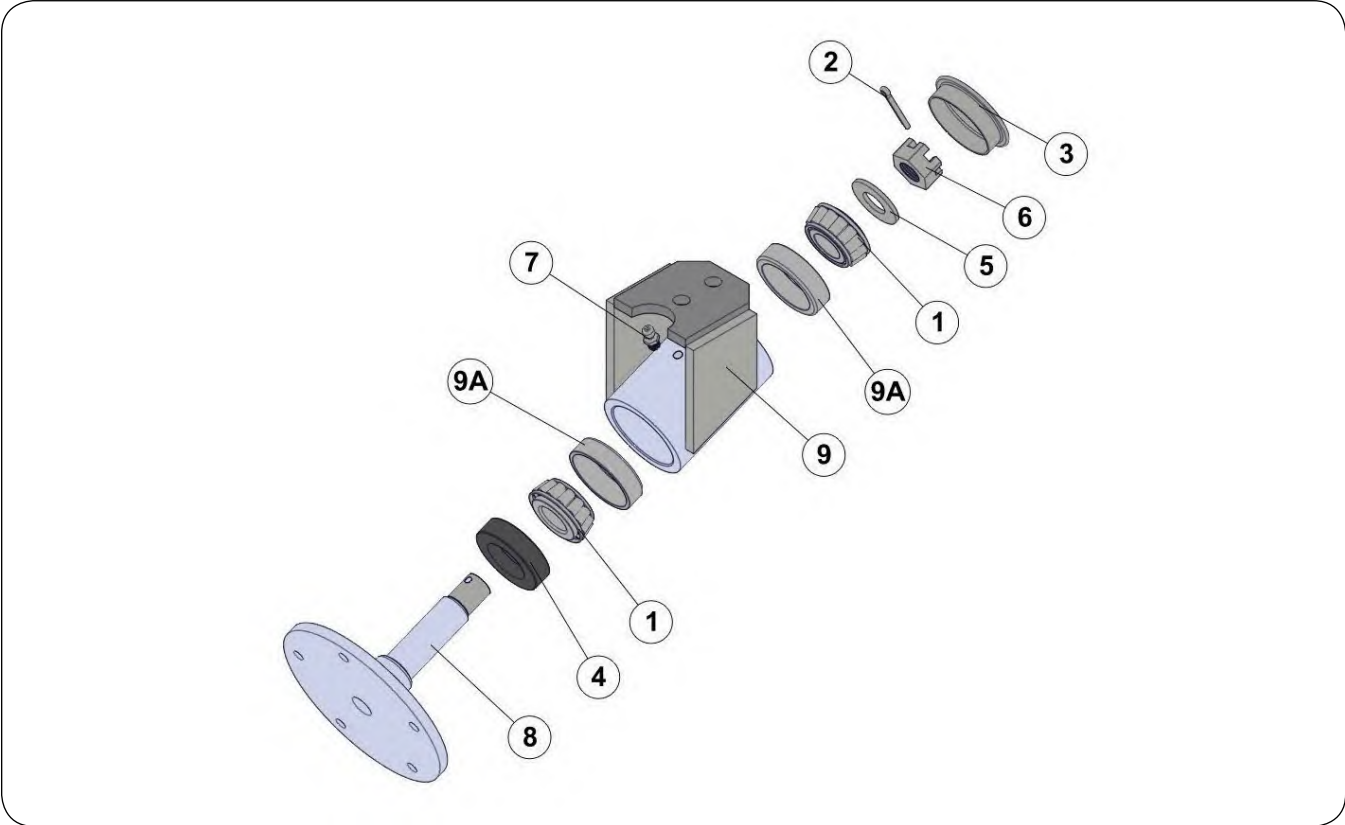

ITEM	PART NUMBER	DESCRIPTION	QTY	NOTES
	JAM7670	Residue Manager Blade Mounting Assembly	-	Includes Items 1-9
1	9789	Bearing Cone, .750" ID (LM11949)	2	
2	9391-023	Cotter Pin, 1/8" Dia. x 1"	1	
3	JAP2729	Hub Cap	1	
4	JAP2742	Grease Seal (10174VB)	1	
5	9791	Flat Washer, 21/32" ID	1	
6	9393-014	Slotted Nut 5/8"-18UNF G2	1	
7	91160	Grease Zerk 1/4"-28 STT	1	
8	JEM3710B	Blade Mounting Weldment	1	
9	JEM6659	Residue Manager Mounting Weldment with Cups	1	
9A	9784	Bearing Cup, 1.781" OD (LM11910)	2	

StripTill Residue Manager Components (J70210646)

Please visit www.unverferth.com/parts/ for the most current parts listing.

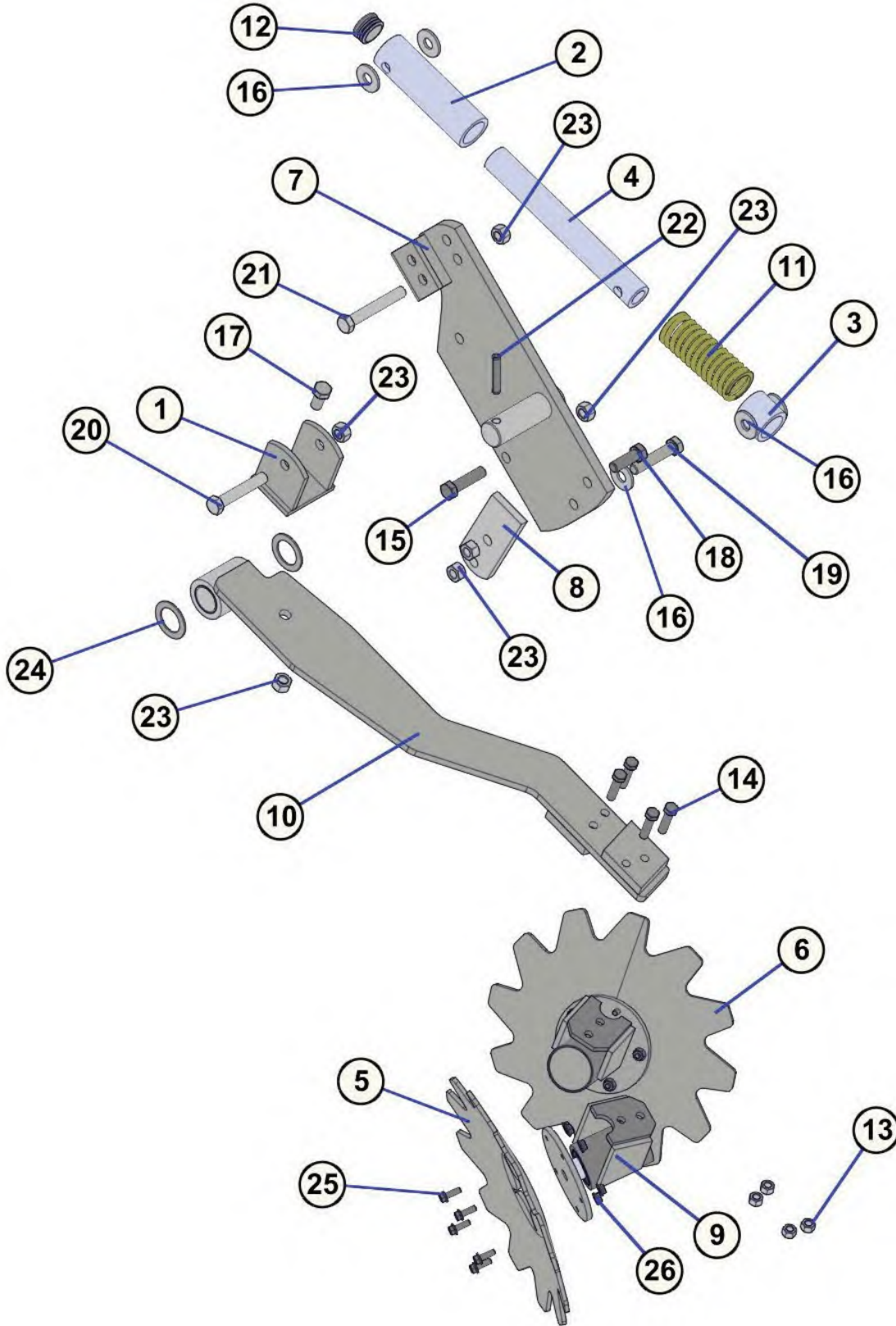

StripTill Residue Manager Components (J70210646)

Please visit www.unverferth.com/parts/ for the most current parts listing.

ITEM	PART NUMBER	DESCRIPTION	QTY	NOTES
	J70210646	StripTill Residue Manager, 1 Row	1	Includes Items 1-26
1	JAM2489	Lower Clevis Plate	1	
2	JAM2490	Upper Spring Tube	1	
3	JAM2491	Spring Collar Bushing	1	
4	JAM2492	Spring Guide Tube	1	
5	JAM7662	Blade 3/16" x 12 1/2" Dia. Left-Hand	1	
6	JAM7663	Blade 3/16" x 12 1/2" Dia. Right-Hand	1	
7	JAM7667	Spring Pivot Arm Mounting Bracket Weldment	1	
8	JAM7669	Arm Stop Bracket	1	
9	JAM7670	Blade Mounting Assembly	2	
10	JAM7671	Bolt-On Blade Mounting Arm Weldment w/Pivot Tube	1	
11	JAP2997	Compression Spring, 1.75" OD X 1.313" ID X 6.00"	1	
12	JAP3116	Tube Plug, 1 3/8" Dia.	1	
13	902875	Lock Nut/Center, 3/8"-16UNC	4	
14	9390-057	Capscrew, 3/8"-16UNC x 1 1/2" G5	4	
15	9390-103	Capscrew, 1/2"-13UNC x 2" G5	1	
16	9405-088	Flat Washer, 1/2" USS	5	
17	9390-099	Capscrew, 1/2"-13UNC x 1" G5	1	
18	9390-101	Capscrew, 1/2"-13UNC x 1 1/2" G5	1	
19	9390-105	Capscrew, 1/2"-13UNC x 2 1/2" G5	1	
20	9390-107	Capscrew, 1/2"-13UNC x 3" G5	1	
21	9390-109	Capscrew, 1/2"-13UNC x 3 1/2" G5	1	
22	9392-180	Roll Pin, 3/8" Dia. x 2"	1	
23	94981	Lock Nut/Center, 1/2"-13UNC	6	
24	91174	Machinery Bushing, 1 7/8" OD x 1 1/4" ID x 14GA	2	
25	97420	Flange Screw, 1/4"-20UNC x 3/4" G5	10	
26	97189	Hex Nut/Large Flange, 1/4"-20UNC	10	

SuperShooter Hitch Assembly Components

Please visit www.unverferth.com/parts/ for the most current parts listing.

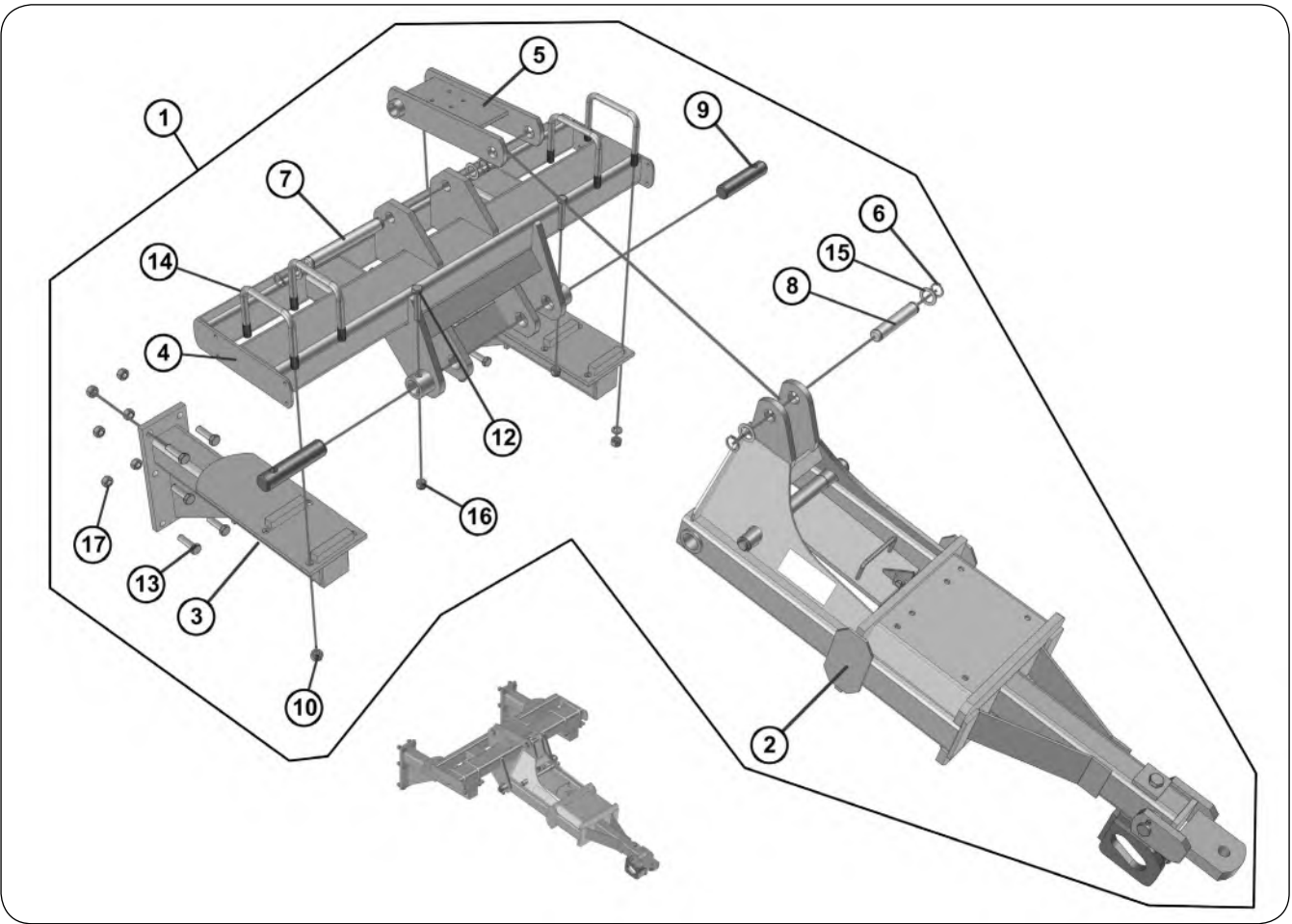

SuperShooter Hitch Assembly Components

Please visit www.unverferth.com/parts/ for the most current parts listing.

ITEM	PART NUMBER	DESCRIPTION	QTY	NOTES
1	JPKG00234BB	SuperShooter Hitch Package	1	Includes Item 2-17
2	JAAM2931BB	Assembly, SuperShooter Hitch, Auto-Lok, Without Pin	1	
3	JAM6220BB	Hitch Mounting Bracket	2	
4	JAM6273BB	Low Bracket, SuperShooter Hitch Mounting	1	
5	JAM6278	Linkage, SuperShooter Hitch, 12 3/4"	1	
6	JAP2711	Snap Ring 1 1/4", External Heavy-Duty Retaining Ring	4	
7	JBM3544	Pin, 1 1/4" Dia. x 9"	1	
8	JBM3547	Pin, 1 1/4" Dia. x 5 3/4"	1	
9	JBM3632	Pin, Category 4, Upper Link	2	
10	9394-016	Hex Nut, 3/4"-10UNC	8	
11	N/A		-	
12	9390-130	Capscrew, 5/8"-11UNC x 3 1/2" G5	2	
13	9390-147	Capscrew, 3/4"-10UNC x 2 1/2" G5	12	
14	JBP3208	U-Bolt, 3/4"-10UNC x 6"W x 5 11/16"L	4	
15	91174	Machinery Bushing, 1 7/8" OD x 1 1/4" ID x 14GA	4	
16	9398-019	Elastic Lock Nut, 5/8"-11UNC	2	
17	9802	Lock Nut/Top, 3/4"-10UNC	12	

SuperShooter Hitch, Low Mounting Components

Please visit www.unverferth.com/parts/ for the most current parts listing.

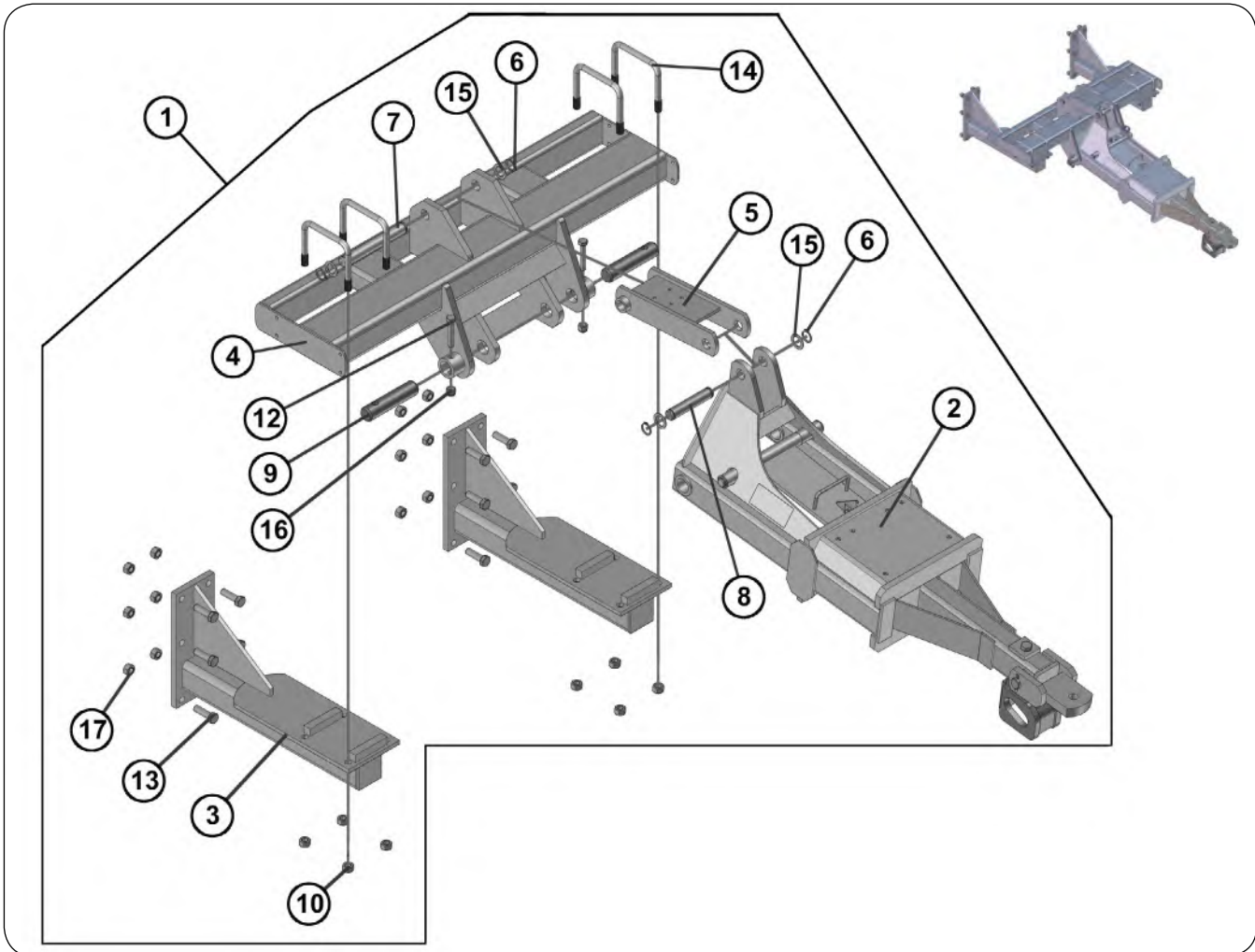

ITEM	PART NUMBER	DESCRIPTION	QTY	NOTES
1	JPKG00247BB	SuperShooter Hitch Assembly, Low Mounting	1	Includes Item 2-17
2	JAAM2931BB	Assembly, SuperShooter Hitch, Auto-Lok, Without Pin	1	
3	JAM6234BB	Bracket, Low Hitch Mounting, At6020 SuperShooter	2	
4	JAM6273BB	Low Bracket, SuperShooter Hitch Mounting	1	
5	JAM6278	Linkage, SuperShooter Hitch, 12 3/4"	1	
6	JAP2711	Snap Ring 1 1/4", External Heavy-Duty Retaining Ring	4	
7	JBM3544	Pin, 1 1/4" Dia. x 9"	1	
8	JBM3547	Pin, 1 1/4" Dia. x 5 3/4"	1	
9	JBM3632	Pin, Category 4, Upper Link	2	
10	9802	Lock Nut, 3/4"-10UNC	8	
11	N/A		-	
12	9390-130	Capscrew, 5/8"-11UNC x 3 1/2" G5	2	
13	9390-147	Capscrew, 3/4"-10UNC x 2 1/2" G5	12	
14	JBP3208	U-Bolt, 3/4"-10UNC x 6"W x 5 11/16"L	4	
15	91174	Machinery Bushing, 1 7/8" OD x 1 1/4" ID x 14GA	4	
16	9398-019	Elastic Lock Nut, 5/8"-11UNC	2	
17	9802	Lock Nut/Top, 3/4"-10UNC	12	

Auto-Lok SuperShooter Hitch Components

Please visit www.unverferth.com/parts/ for the most current parts listing.

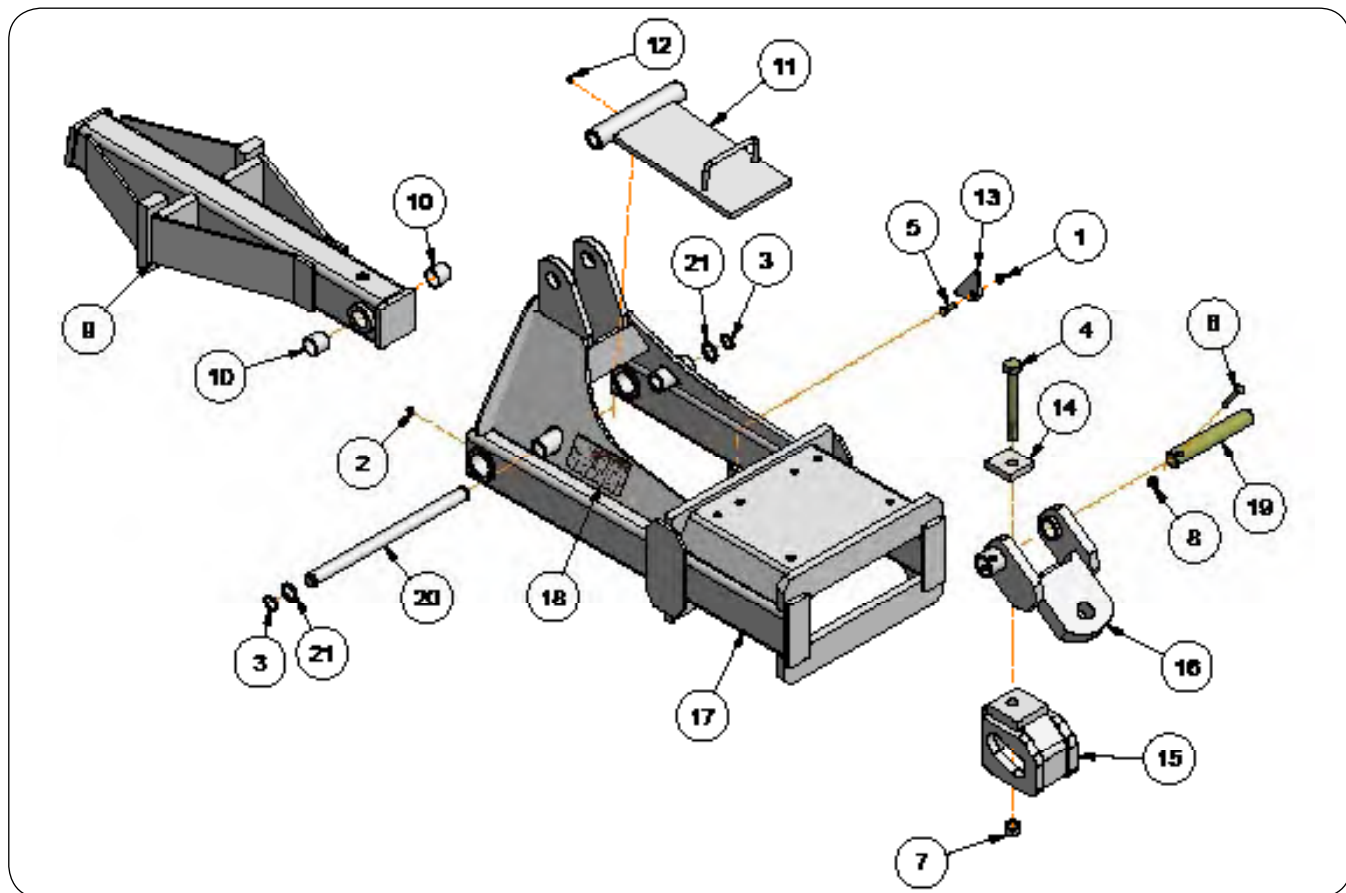

ITEM	PART NUMBER	DESCRIPTION	QTY	NOTES
1	902875	Lock Nut/Center, 3/8"-16UNC	1	
2	91160	Grease Zerk 1/4"-28 STT	2	
3	91192	Retaining Ring, 1"	2	
4	91299-157	Capscrew, 3/4"-10UNC x 6" G8	1	
5	9390-055	Capscrew, 3/8"-16UNC x 1" G5	1	
6	9390-061	Capscrew, 3/8"-16UNC x 2 1/2" G5	1	
7	97025	Lock Nut/Top, 3/4"-10UNC	1	
8	9928	Lock Nut/Top, 3/8"-16UNC	1	
9	JAM4533BB	Hitch, Swing Slide Insert, Standard =BLUE=	1	
10	JAP2156	Bushing, 1 13/32" OD x 1 1/4" ID x 1 1/4"	2	
11	JAM4536	Insert Latch, SuperShooter Hitch	1	
12	91160	Grease Zerk 1/4"-28 STT	1	
13	JAM4539	Latch	1	
14	JAM4540	Backing Plate, Transport Chain Loop, Std SuperShooter Hitch	1	
15	JAM6230	Bracket, Transport Chain Attachment	1	
16	JAM6233	Flipper Hitch, Standard, SuperShooter Hitch	1	
17	JAM6272BB	Hitch, SuperShooter, Main Frame =BLUE=	1	
18	JAP2585	Decal, Hitch Capacity 25,000 Lbs.	2	
19	JBM3465	Pin, 1 1/4" x 7 3/4"	1	
20	JBM3551	Pin, 1" Dia. x 15 11/16"	1	
21	JBP3215	Machinery Bushing, 1 1/2" OD x 1" ID x 14GA	2	

SuperShooter III Connection - Single 1.25" Plumbing

Please visit www.unverferth.com/parts/ for the most current parts listing.

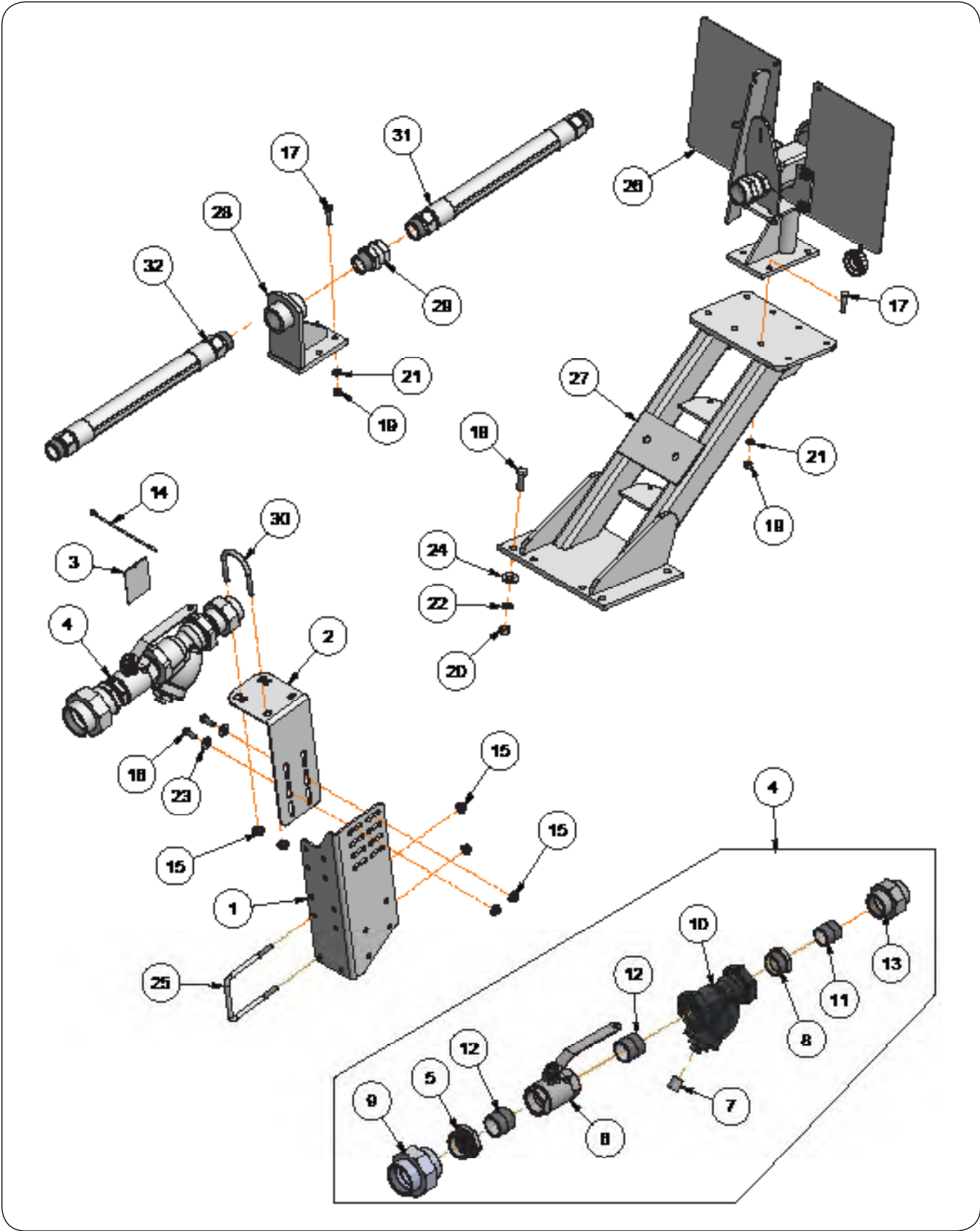

SuperShooter III Connection - Single 1.25" Plumbing

Please visit www.unverferth.com/parts/ for the most current parts listing.

ITEM	PART NUMBER	DESCRIPTION	QTY	NOTES
1	44258B	Support Mounting Plate	1	
2	44260B	Inlet Plumbing Support Plate	1	
3	44568	Leak Test Tag (Double Sided)	1	
4	44635	NH3 Supply Plumbing Assembly - Single 1.25"	1	Includes Items 4A-4I
5	9503331	Hex Reducer Bushing, 2-11.5 NPT Male x 1 1/2-11.5 NPT Female	1	
6	9503342	Manual Ball Valve, 1 1/2" (Stainless Steel)	1	
7	9503749	Strainer Magnet, 7/8" Dia. x 1"	1	
8	JCP2584	Hex Reducer Bushing, 1 1/2-11.5 NPT Male x 1 1/4-11.5 NPT Female	1	
9	JCP2722	Pipe Union, 2-11.5 NPT Female Both Ends	1	
10	JCP2723	NH3 Strainer "Y", 20 Mesh (Stainless Steel Screen)	1	
11	JCP2727	Nipple, 1 1/4-11.5 NPT Male x 1 5/8 (Close)	1	
12	JCP2728	Nipple, 1 1/2-11.5 NPT male x 1 3/4 (Close)	2	
13	JCP2893	Pipe Union, 1 1/4-11.5 NPT Female Both Ends	1	
14	9000106	Cable Tie, 7 1/2"	1	
15	91263	Nut/Large Flange, 3/8"-16UNC	10	
16	9390-055	Capscrew, 3/8"-16UNC x 1" G5	4	
17	9390-057	Capscrew, 3/8"-16UNC x 1 1/2" G5	8	
18	9390-101	Capscrew, 1/2"-13UNC x 1 1/2" G5	6	
19	9394-006	Hex Nut 3/8"-16UNC	8	
20	9394-010	Hex nut, 1/2"-13UNC	6	
21	9404-021	Lock Washer, 3/8"	8	
22	9404-025	Lock Washer, 1/2"	6	
23	9405-076	Flat Washer, 3/8" USS	4	
24	9405-088	Flat Washer, 1/2" USS	6	
25	9501076	U-Bolt, 3/8"-16UNC x 5", 4 3/8" C/C	2	
26	JAAM3514	SuperShooter Connection - 1.25" Connection	1	
27	JAM6277	SuperShooter Connection Riser Weldment	1	
28	JCM2312	Coupler Bracket, Single 1 1/4" NPT	1	
29	JCP2593	NH3 Hose, 1 1/4" x 64", 1 1/4-11.5 NPTF Male x 1 1/4-11.5 NPTF Male, 350 PSI	1	
30	JCP2890	NH3 Hose, 1 1/4" x 120", 1 1/4-11.5 NPTF Male x 1 1/4-11.5 NPTF Male, 350 PSI	1	
31	JDP4397	Pipe Swivel Union, 1 1/4"-11.5 NPT Male x 1 1/4"-11.5 NPTSM Female	1	
32	TA1-902545-0	U-Bolt, 3/8"-16UNC x 3 7/16", 2 3/4" C/C	1	

SuperShooter III Connection - Double 1.25" Plumbing

Please visit www.unverferth.com/parts/ for the most current parts listing.

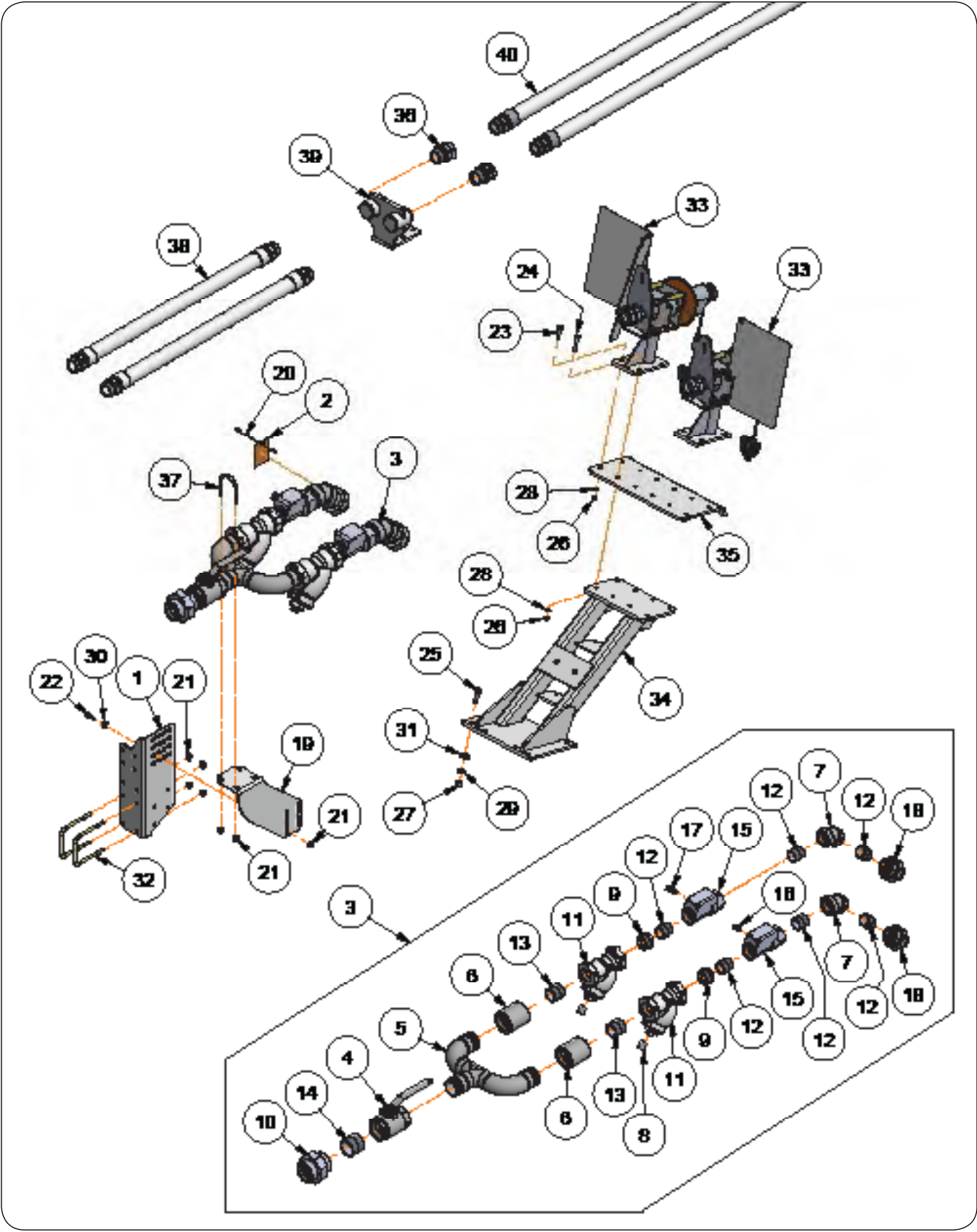

SuperShooter III Connection - Double 1.25" Plumbing

Please visit www.unverferth.com/parts/ for the most current parts listing.

ITEM	PART NUMBER	DESCRIPTION	QTY	NOTES
1	44258B	Support Mounting Plate	1	
2	44568	Leak Test Tag (Double Sided)	2	
3	44678	NH3 Supply Plumbing Assembly - Double 1.25"	1	Includes Items 4-18
4	9503346	Manual Ball Valve 2" (Stainless Steel)	1	
5	9503347	Inlet Manifold 2" NPT Weldment (Stainless Steel)	1	
6	9503477	Reducer Coupling, 2-11.5 NPT Female x 1 1/2-11.5 NPT Female	2	
7	9503478	45° Elbow, 1 1/4-11.5 NPT Female x 1 1/4-11.5 NPT Female	2	
8	9503749	Strainer Magnet, 7/8" Dia. x 1"	2	
9	JCP2584	Hex Reducer Bushing, 1 1/2-11.5 NPT Male x 1 1/4-11.5 NPT Female	2	
10	JCP2722	Pipe Union, 2-11.5 NPT Female Both Ends	1	
11	JCP2723	NH3 Strainer "Y", 20 Mesh (Stainless Steel Screen)	2	
12	JCP2727	Nipple, 1 1/4-11.5 NPT Male x 1 5/8 (Close)	6	
13	JCP2728	Nipple, 1 1/2-11.5 NPT Male x 1 3/4 (Close)	2	
14	JCP2729	Nipple, 2-11.5 NPT Male x 2 (Close)	1	
15	JCP2735	Back Check Valve	2	
16	JCP2837	Hydrostatic Relief Valve	1	
17	JCP2838	Bleeder Valve, 1/4-18 NPT w/T-Handle	1	
18	JCP2893	Pipe Union, 1 1/4-11.5 NPT Female Both Ends	2	
19	46182B	Inlet Plumbing Support Plate	1	
20	9000106	Cable Tie, 7 1/2"	2	
21	91263	Nut/Large Flange, 3/8"-16UNC	10	
22	9390-055	Capscrew, 3/8"-16UNC x 1" G5	4	
23	9390-057	Capscrew, 3/8"-16UNC x 1 1/2" G5	16	
24	9390-059	Capscrew, 3/8"-16UNC x 2" G5	4	
25	9390-101	Capscrew, 1/2"-13UNC x 1 1/2" G5	6	
26	9394-006	Hex Nut 3/8"-16UNC	20	
27	9394-010	Hex nut, 1/2"-13UNC	6	
28	9404-021	Lock Washer, 3/8"	20	
29	9404-025	Lock Washer, 1/2"	6	
30	9405-076	Flat Washer, 3/8" USS	4	
31	9405-088	Flat Washer, 1/2" USS	6	
32	9501076	U-Bolt, 3/8"-16UNC x 5", 4 3/8" C/C	2	
33	JAAM3514	SuperShooter Connection - 1.25" Connection	2	
34	JAM6277	SuperShooter Connection Riser Weldment	1	
35	JAM7664	Mounting Plate, 10" x 16 1/2"	1	
36	JDP4397	Pipe Swivel Union, 1 1/4"-11.5 NPT Male x 1 1/4"-11.5 NPTSM Female	2	
37	TA1-902545-0	U-Bolt, 3/8"-16UNC x 3 7/16", 2 3/4" C/C	1	
38	9503903	NH3 Hose, 1 1/4" x 108", 1 1/4-11.5 NPTF Male x 1 1/4-11.5 NPTF Male, 350 PSI	2	
39	JCM2313	Coupler Bracket, Double 1 1/4" NPT	1	
40	JCP2593	NH3 Hose, 1 1/4" x 64", 1 1/4-11.5 NPTF Male x 1 1/4-11.5 NPTF Male, 350 PSI	2	

SuperShooter III Components - 1.25" Connection (JAAM3514)

Please visit www.unverferth.com/parts/ for the most current parts listing.

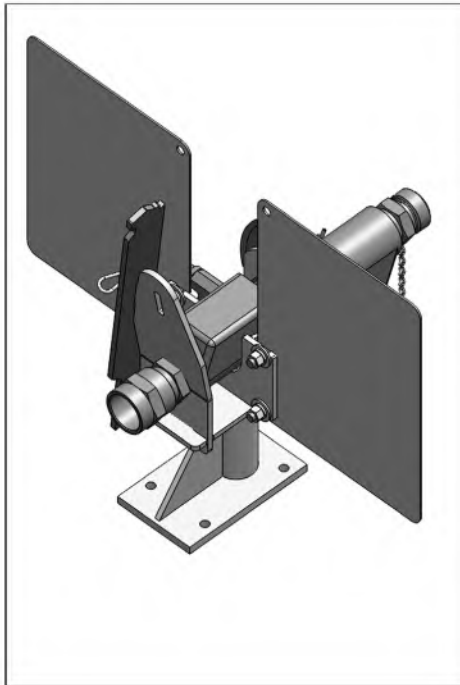
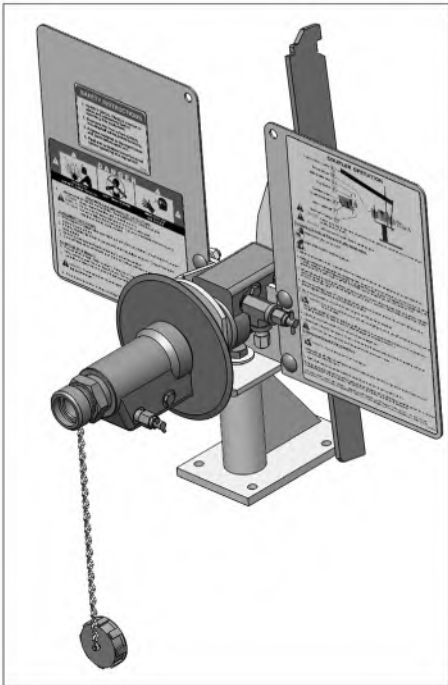
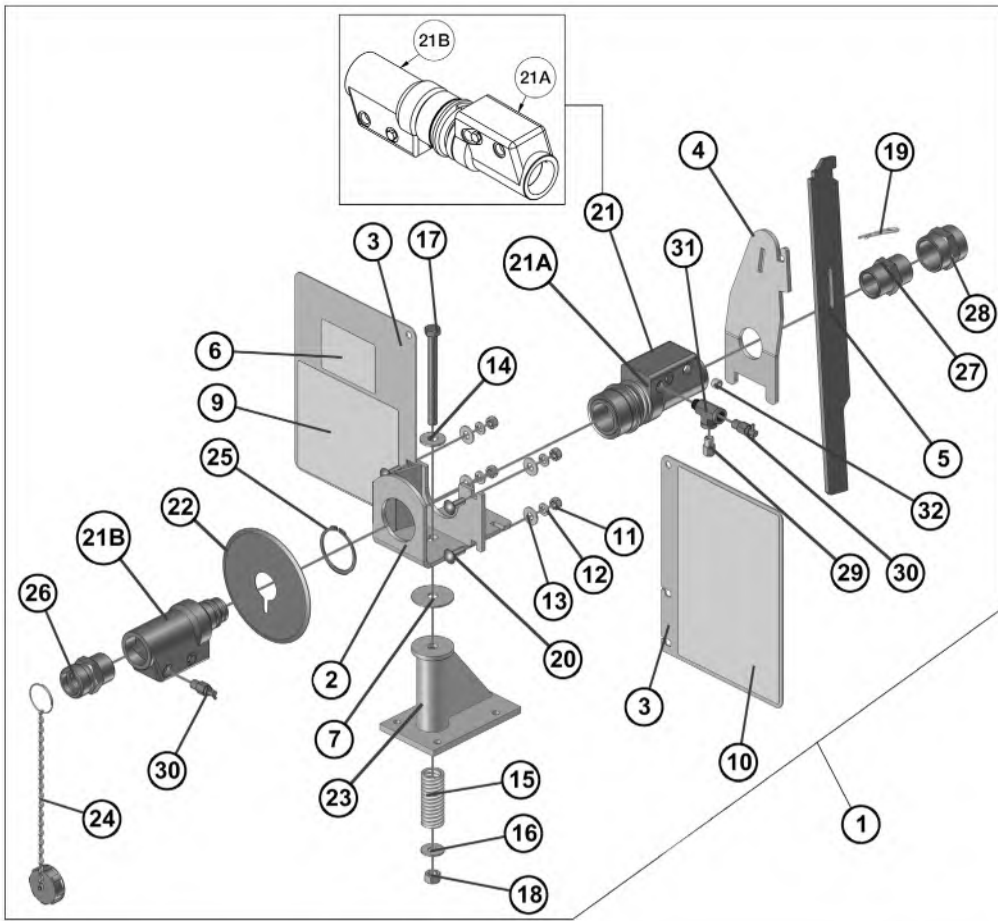

SuperShooter III Components - 1.25" Connection (JAAM3514)

Please visit www.unverferth.com/parts/ for the most current parts listing.

ITEM	PART NUMBER	DESCRIPTION	QTY	NOTES
1	JAAM3514	SuperShooter III / 1 1/4" Squibb Coupler / Bodyguard III	-	Includes Items 2-32
2	JAM7634	Valve Mounting Weldment	1	
3	JAM7635	Decal Plate	2	
4	JAM7660	Coupler Release Plate	1	
5	JAM7661	Coupler Release Handle	1	
6	JAP2227	Decal, Safety Instruction, NH3	1	
7	JAP2418	Spring Retainer Washer	1	
9	JAP2973	Decal, SuperShooters III, Hook-Up Instructions	1	
10	JAP2974	Decal, SuperShooter III, Squibb Coupler Operation	1	
11	9394-006	Hex Nut, 3/8"-16UNC	4	
12	9404-021	Lock Washer, 3/8"	4	
13	9405-074	Flat Washer, 3/8" SAE	4	
14	9405-088	Flat Washer, 1/2" USS	1	
15	JBP3084	Compression Spring 1.25" Dia. x 4 1/2"	1	
16	9405-082	Flat Washer, 7/16" USS	1	
17	9390-114	Capscrew, 1/2"-13UNC x 5 1/2" G5	1	
18	94981	Lock Nut/Center, 1/2"-13UNC	1	
19	JBP3504	Hairpin Cotter 1/8" Dia. x 2 1/2"	1	
20	9388-051	Carriage Bolt, 3/8"-16UNC x 1" G5	4	
21	JCCP2403	Flo-Max 1 1/4" Coupler Set Less Bracket, FM126-1000	1	Includes Items 21A & 21B
	JCP2457	Flo-Max 1 1/4" Coupler O-Ring Kit	-	
21A	JCP2405	Flo-Max 1 1/4" Coupler Female Half, SFM125/126-1100	1	
21B	JCP2406	Flo-Max 1 1/4" Coupler Male Half, SFM125/126-1200	1	
22	9503899	Body Guard, SuperShooter 1 1/4", Smooth Gloss Polycarbonate Orange w/Black Screen Print	1	
23	JCM2320	SuperShooter Pedestal Weldment	1	
24	JCP2401	Dust Cap with Chain	1	
25	JCP2416	Snap Ring For Flo-Max 1 1/4" Coupler	1	
26	JCP2423	ACME Adapter 1 1/4" MPT x 1 3/4" AM	1	
27	JCP2522	Hex Nipple, 1 1/4" NPT, 3000 PSI Trivalent	1	
28	JCP2566	Coupling, 1 1/4" FPT., Steel	1	
29	JCP2837	Hydrostatic Relief Valve, Pressure Relief Set At 350 PSI Inlet 1/4"-18 NPT	1	
30	JCP2838	Bleeder Valve 1/4"-18 NPT w/T-Handle	2	
31	TA0-934667-0	Street Tee, 1/4"-18 NPTF Male x 1/4"-18 NPTF Female x 1/4"-18 NPT Female	1	
32	JDP4657	Hollow Hex Pipe Plug, 1/4"-18 NPT, Stainless Steel	1	

SuperShooter III Single 1 1/4" Assembly, Less Distribution

Please visit www.unverferth.com/parts/ for the most current parts listing.

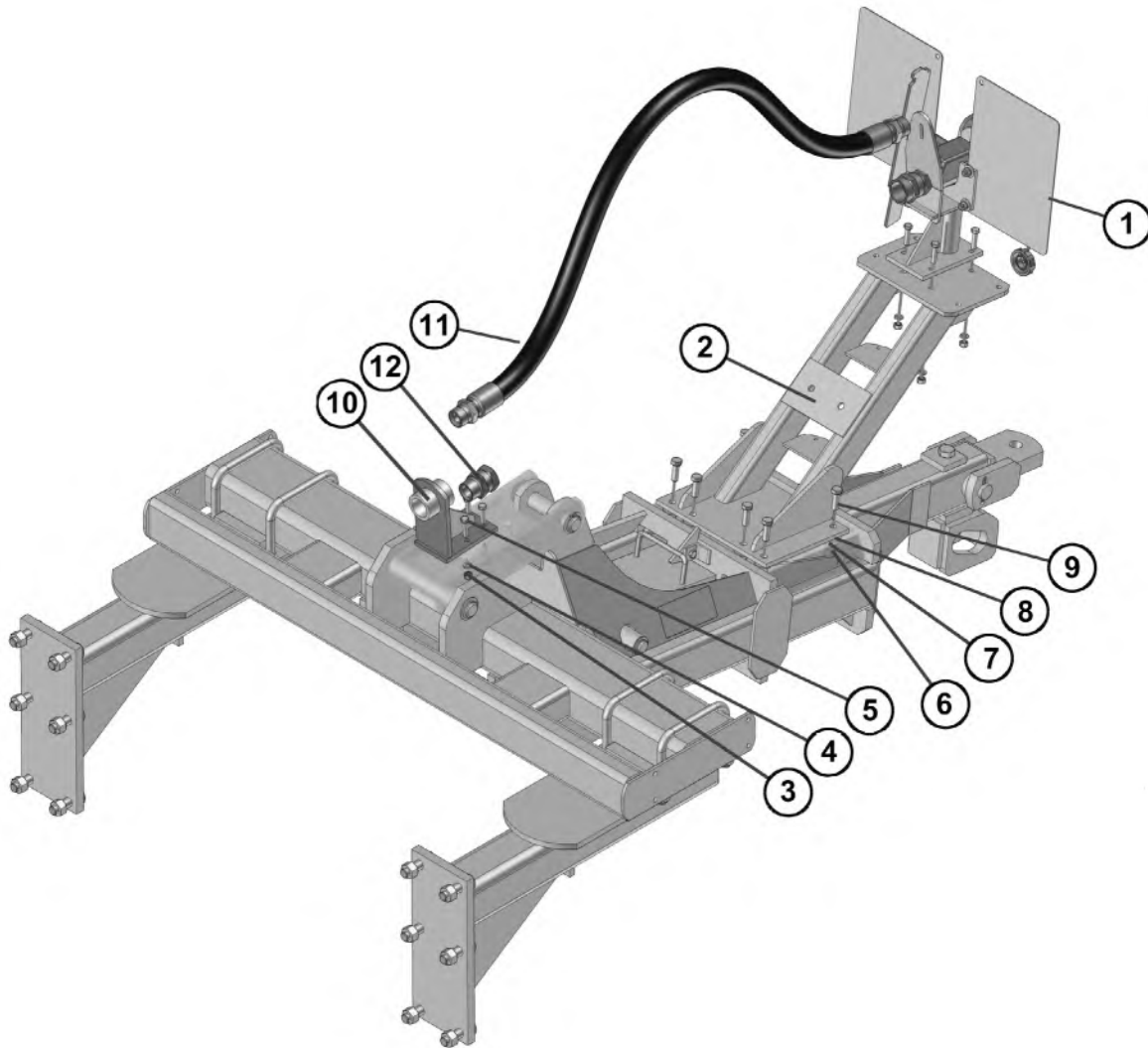

ITEM	PART NUMBER	DESCRIPTION	QTY	NOTES
	J66000136	SuperShooter III Single 1 1/4" Assembly, Less Distribution	-	Includes Items 1-12
1	JAAM3514	SuperShooter III / 1 1/4" Squibb Coupler / Bodyguard III	2	
2	JAM6277	SuperShooter Riser, Auto-Lok Hitch	2	
3	9394-006	Hex Nut, 3/8"-16UNC	2	
4	9404-021	Lock Washer, 3/8"	2	
5	9390-057	Capscrew, 3/8"-16UNC x 1 1/2" G5	2	
6	9394-010	Hex Nut, 1/2"-13UNC	2	
7	9404-025	Lock Washer, 1/2"	2	
8	9405-088	Flat Washer, 1/2" USS	4	
9	9390-101	Capscrew, 1/2"-13UNC x 1 1/2" G5	4	
10	JCM2312	Coupler Bracket, Single, 1 1/4" NPT	8	
11	JCP2593	Hose, NH3, 1 1/4" x 64"	4	
12	JDP4397	Adapter, 1 1/4" NPTF Male x 1 1/4" NPSM Swivel	2	

SuperShooter III Max Single 1 1/2" Assembly, Less Distribution

Please visit www.unverferth.com/parts/ for the most current parts listing.

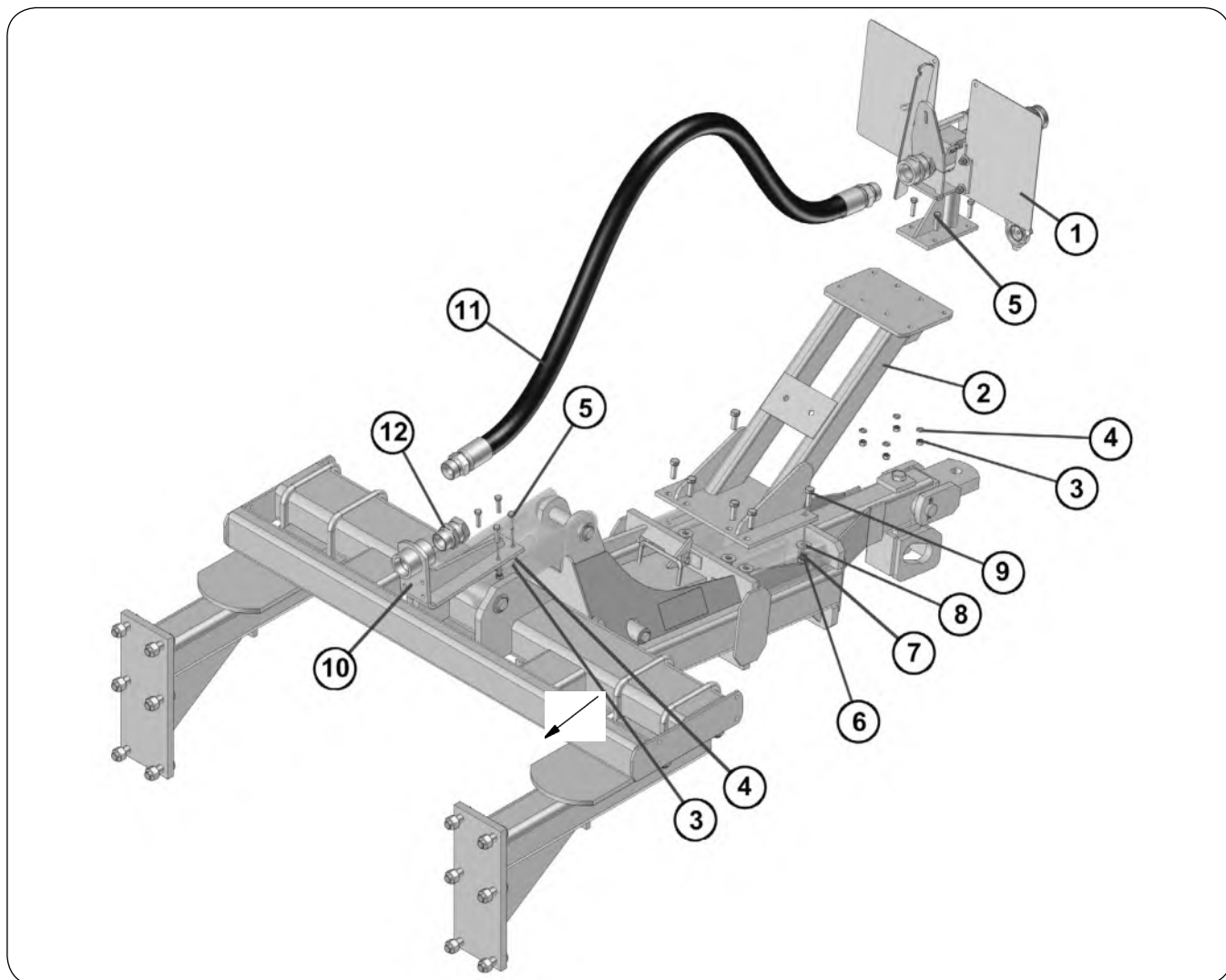

ITEM	PART NUMBER	DESCRIPTION	QTY	NOTES
	J66000150	SuperShooter III Max Single 1 1/2" Assembly, Less Distribution	-	Includes Items 1-12
1	JAAM3516	SuperShooter III Max / 1 1/2" Squibb Coupler / Bodyguard III	2	
2	JAM6277	SuperShooter Riser, Auto-Lok Hitch	2	
3	9394-006	Hex Nut, 3/8"-16UNC	2	
4	9404-021	Lock Washer, 3/8"	2	
5	9390-057	Capscrew, 3/8"-16UNC x 1 1/2" G5	2	
6	9394-010	Hex Nut, 1/2"-13UNC	2	
7	9404-025	Lock Washer, 1/2"	2	
8	9405-088	Flat Washer, 1/2" USS	4	
9	9390-101	Capscrew, 1/2"-13UNC x 1 1/2" G5	4	
10	JCM2324	Coupler Bracket, Single, 1 1/2" NPT	8	
11	JCP2595	Hose, NH3, 1 1/2" x 74"	4	
12	JDP4675	Adapter, 1 1/2" NPTF Male x 1 1/2" NPSM Swivel	2	

SuperShooter III Connection - Single 1.5" Plumbing

Please visit www.unverferth.com/parts/ for the most current parts listing.

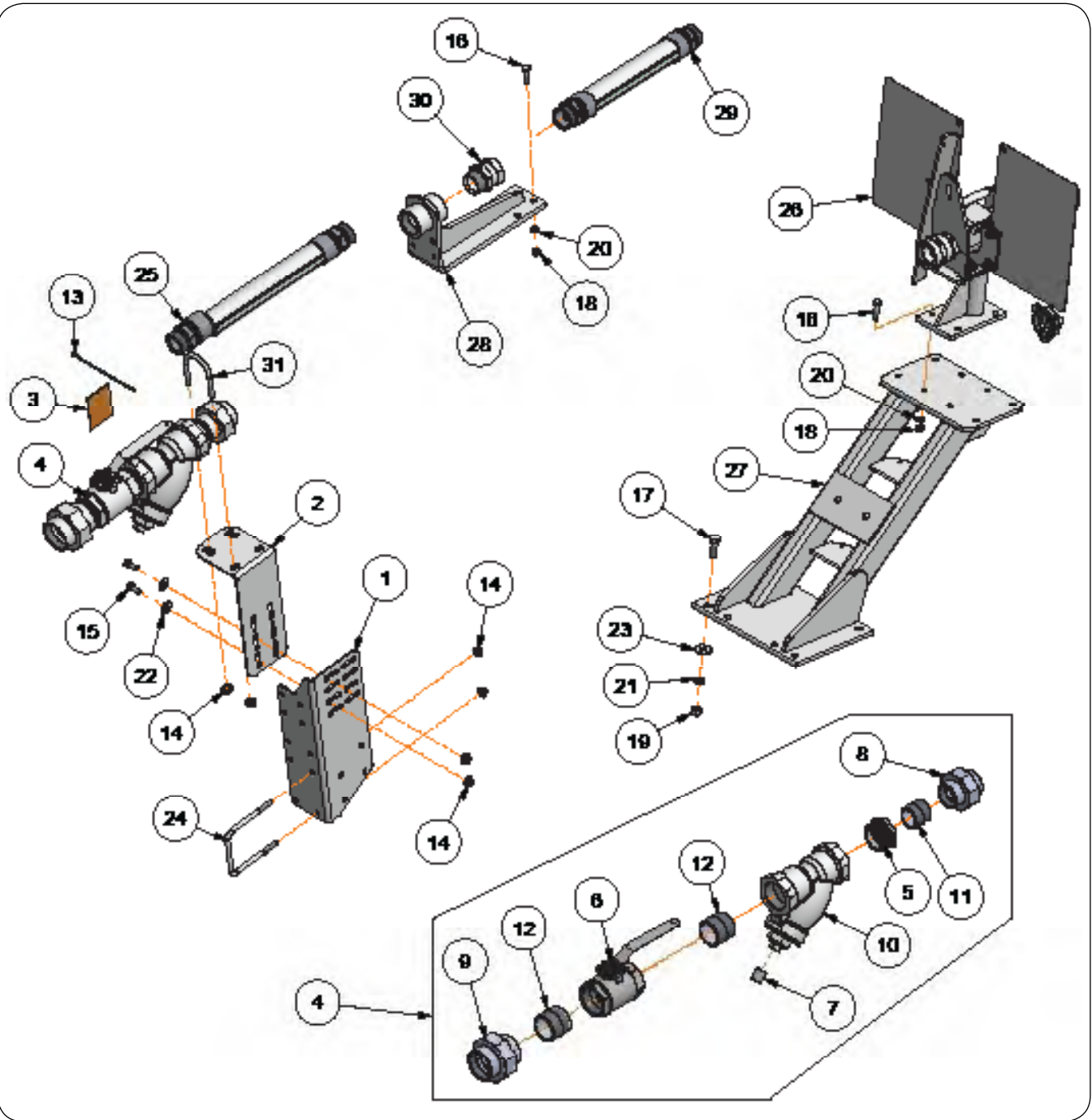

SuperShooter III Connection - Single 1.5" Plumbing

Please visit www.unverferth.com/parts/ for the most current parts listing.

ITEM	PART NUMBER	DESCRIPTION	QTY	NOTES
1	44258B	Support Mounting Plate	1	
2	44260B	Inlet Plumbing Support Plate	1	
3	44568	Leak Test Tag (Double Sided)	1	
4	44690	NH3 Supply Plumbing Assembly - Single 1.5"	1	Includes Items 5-12
5	9503331	Hex Reducer Bushing, 2-11.5 NPT Male x 1 1/2-11.5 NPT Female	1	
6	9503346	Manual Ball Valve 2" (Stainless Steel)	1	
7	9503749	Strainer Magnet, 7/8" Dia. x 1"	1	
8	JCP2721	Pipe Union, 1 1/2-11.5 NPT Female Both Ends	1	
9	JCP2722	Pipe Union, 2-11.5 NPT Female Both Ends	1	
10	JCP2724	NH3 Strainer "Y", 2-11.5 NPT (20 Mesh Stainless Steel Screen)	1	
11	JCP2728	Nipple, 1 1/2-11.5 NPT Male x 1 3/4 (Close)	1	
12	JCP2729	Nipple, 2-11.5 NPT Male x 2 (Close)	2	
13	9000106	Cable Tie, 7 1/2"	1	
14	91263	Nut/Large Flange, 3/8"-16UNC	10	
15	9390-055	Capscrew, 3/8"-16UNC x 1" G5	4	
16	9390-057	Capscrew, 3/8"-16UNC x 1 1/2" G5	8	
17	9390-101	Capscrew, 1/2"-13UNC x 1 1/2" G5	6	
18	9394-006	Hex Nut 3/8"-16UNC	8	
19	9394-010	Hex nut, 1/2"-13UNC	6	
20	9404-021	Lock Washer, 3/8"	8	
21	9404-025	Lock Washer, 1/2"	6	
22	9405-076	Flat Washer, 3/8" USS	4	
23	9405-088	Flat Washer, 1/2" USS	6	
24	9501076	U-Bolt, 3/8"-16UNC x	2	
25	9503378	NH3 Hose, 1 1/2" x 120", 1 1/2-11.5 NPTF Male x 1 1/2-11.5 NPTF Male, 350 PSI	1	
26	JAAM3516	SuperShooter Connection - 1.5" Connection	1	
27	JAM6277	SuperShooter Connection Riser Weldment	1	
28	JCM2324	Coupler Bracket, Single 1 1/2" NPT	1	
29	JCP2595	NH3 Hose, 1 1/2" x 72", 1 1/2-11.5 NPTF Male x 1 1/2-11.5 NPTF Male, 350 PSI	1	
30	JDP4675	Pipe Swivel Union, 1 1/2"-11.5 NPT Male x 1 1/2"-11.5 NPTSM Female	1	
31	TA1-902545-0	U-Bolt, 3/8"-16UNC x 3 7/16", 2 3/4" C/C	1	

SuperShooter III Connection - Double 1.5" Plumbing

Please visit www.unverferth.com/parts/ for the most current parts listing.

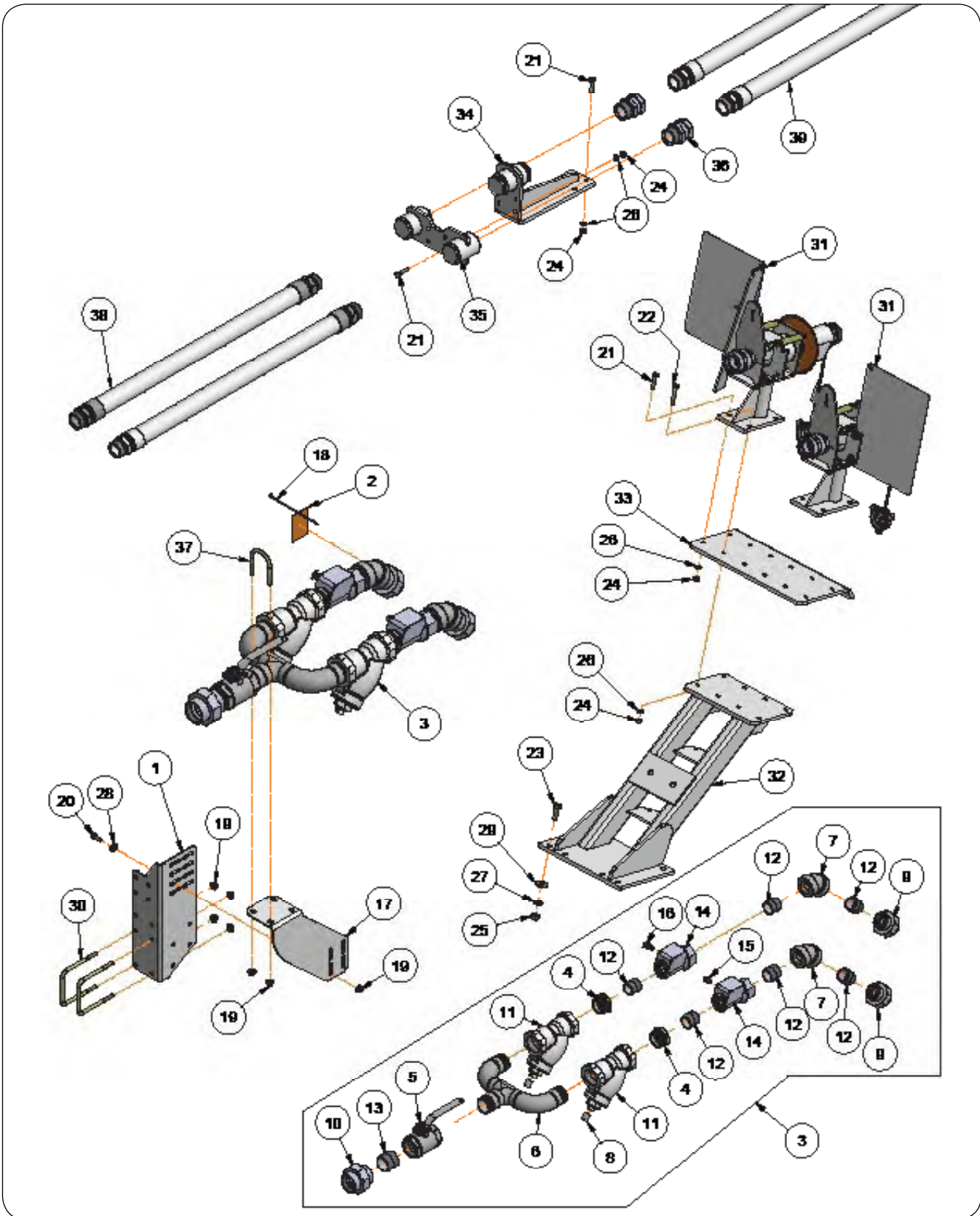

SuperShooter III Connection - Double 1.5" Plumbing

Please visit www.unverferth.com/parts/ for the most current parts listing.

ITEM	PART NUMBER	DESCRIPTION	QTY	NOTES
1	44258B	Support Mounting Plate	1	
2	44568	Leak Test Tag (Double Sided)	2	
3	44679	NH3 Supply Plumbing Assembly - Double 1.5"	1	Includes Items 4-16
4	9503331	Hex Reducer Bushing, 2-11.5 NPT Male x 1 1/2-11.5 NPT Female	2	
5	9503346	Manual Ball Valve 2" (Stainless Steel)	1	
6	9503347	Inlet Manifold 2" NPT Weldment (Stainless Steel)	1	
7	9503479	45° Elbow, 1 1/2-11.5 NPT Female x 1 1/2-11.5 NPT Female	2	
8	9503749	Strainer Magnet, 7/8" Dia. x 1"	2	
9	JCP2721	Pipe Union, 1 1/2-11.5 NPT Female Both Ends	2	
10	JCP2722	Pipe Union, 2-11.5 NPT Female Both Ends	1	
11	JCP2724	NH3 Strainer "Y", 2-11.5 NPT (20 Mesh Stainless Steel Screen)	2	
12	JCP2728	Nipple, 1 1/2-11.5 NPT Male x 1 3/4 (Close)	6	
13	JCP2729	Nipple, 2-11.5 NPT Male x 2 (Close)	1	
14	JCP2736	Back Check Valve, 1 1/2 Full Port Swing Valve 1 1/2-11.5 NPT Female	2	
15	JCP2837	Hydrostatic Relief Valve	1	
16	JCP2838	Bleeder Valve 1/4-18 NPT w/T-Handle	1	
17	46182B	Inlet Plumbing Support Plate	1	
18	9000106	Cable Tie, 7 1/2"	2	
19	91263	Nut/Large Flange, 3/8"-16UNC	10	
20	9390-055	Capscrew, 3/8"-16UNC x 1" G5	4	
21	9390-057	Capscrew, 3/8"-16UNC x 1 1/2" G5	16	
22	9390-059	Capscrew, 3/8"-16UNC x 2" G5	4	
23	9390-101	Capscrew, 1/2"-13UNC x 1 1/2" G5	6	
24	9394-006	Hex Nut 3/8"-16UNC	20	
25	9394-010	Hex nut, 1/2"-13UNC	6	
26	9404-021	Lock Washer, 3/8"	20	
27	9404-025	Lock Washer, 1/2"	6	
28	9405-076	Flat Washer, 3/8" USS	4	
29	9405-088	Flat Washer, 1/2" USS	6	
30	9501076	U-Bolt, 3/8"-16UNC x 5", 4 3/8" C/C	2	
31	JAAM3516	SuperShooter Connection - 1.5" Connection	2	
32	JAM6277	SuperShooter Connection Riser Weldment	1	
33	JAM7664	Mounting Plate, 10" x 16 1/2"	1	
34	JCM2324	Coupler Bracket, Single 1 1/2" NPT	1	
35	JCM2325	Coupler Bracket, Double 1 1/2" NPT	1	
36	JDP4675	Pipe Swivel Union, 1 1/2"-11.5 NPT Male x 1 1/2"-11.5 NPTSM Female	2	
37	TA1-902545-0	U-Bolt, 3/8"-16UNC x 3 7/16", 2 3/4" C/C	1	
38	9503906	NH3 Hose, 1 1/2" x 108", 1 1/2-11.5 NPTF Male x 1 1/2-11.5 NPTF Male, 350 PSI	2	
39	JCP2595	NH3 Hose, 1 1/2" x 72", 1 1/2-11.5 NPTF Male x 1 1/2-11.5 NPTF Male, 350 PSI	2	

SuperShooter III Components - 1.5" Connection (JAAM3516)

Please visit www.unverferth.com/parts/ for the most current parts listing.

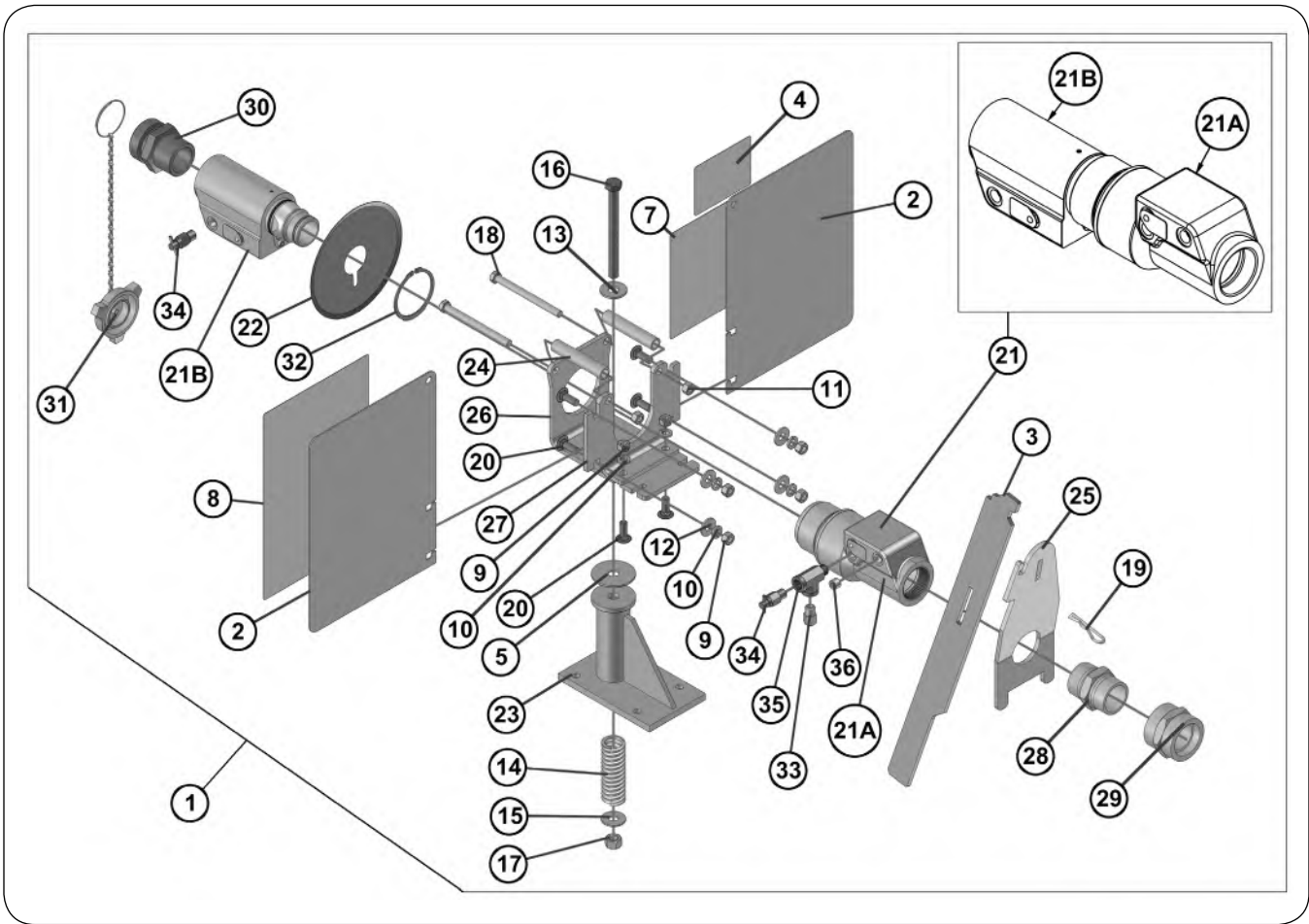

SuperShooter III Components - 1.5" Connection (JAAM3516)

Please visit www.unverferth.com/parts/ for the most current parts listing.

ITEM	PART NUMBER	DESCRIPTION	QTY	NOTES
1	JAAM3516	SuperShooter III Max / 1 1/2" Squibb Coupler / Bodyguard III	-	Includes Items 2-36
2	JAM7635	Decal Plate	2	
3	JAM7661	Coupler Release Handle	1	
4	JAP2227	Decal, Safety Instruction, NH3	1	
5	JAP2418	Spring Retainer Washer	1	
7	JAP2973	Decal, SuperShooters III, Hook-Up Instructions	1	
8	JAP2974	Decal, SuperShooter III, Squibb Coupler Operation	1	
9	9394-006	Hex Nut, 3/8"-16UNC	6	
10	9404-021	Lock Washer, 3/8"	6	
11	902875	Lock Nut/Center, 3/8"-16UNC	2	
12	9405-076	Flat Washer, 3/8" USS	4	
13	9405-088	Flat Washer, 1/2" USS	1	
14	JBP3084	Compression Spring 1.25" Dia. x 4 1/2"	1	
15	9405-082	Flat Washer, 7/16" USS	1	
16	9390-114	Capscrew, 1/2"-13UNC x 5 1/2" G5	1	
17	94981	Lock Nut/Center, 1/2"-13UNC	1	
18	9390-068	Capscrew, 3/8"-16UNC x 4 1/2" G5	2	
19	JBP3504	Hairpin Cotter 1/8" Dia. x 2 1/2"	1	
20	9388-051	Carriage Bolt, 3/8"-16UNC x 1" G5	6	
21	JCCP2405	Flo-Max 1 1/2" Coupler Set Less Bracket, FM150-1000	1	Includes Items 21A & 21B
	9504234	Flo-Max 1 1/2" Coupler, O-Ring Kit	-	
21A	JCP2691	Flo-Max 1 1/2" Coupler Female Half, SFM150-1100	1	
21B	JCP2692	Flo-Max 1 1/2" Coupler Male Half, SFM150-1200	1	
22	9503900	Body Guard, SuperShooter 1 1/2", Smooth Gloss Polycarbonate Orange w/Black Screen Print	1	
23	JCM2320	SuperShooter Pedestal Weldment	1	
24	JCM2322	Spacer Tube	2	
25	JCM2323	Coupler Release Plate	1	
26	JCM2326	Valve Mounting Plate	1	
27	JCM2327	Decal Mounting Plate	1	
28	JCP2685	Hex Pipe Nipple 1 1/2"-11 1/2" NPTF Male x 1 1/2"-11 1/2" NPTF Male	1	
29	JCP2686	Pipe Coupling 1 1/2"-11 1/2" NPTF Female x 1 1/2"-11 1/2" NPTF Female	1	
30	JCP2688	Adapter NH3, 2 1/4" ACME Male x 1 1/2" MPT	1	
31	JCP2689	Dust Cap 2 1/4" ACME Female w/Chain & Snap Ring	1	
32	JCP2693	Snap Ring 2 11/16" Dia. x .078", External Retaining Ring	1	
33	JCP2837	Hydrostatic Relief Valve, Pressure Relief Set At 350 PSI Inlet 1/4"-18 NPT	1	
34	JCP2838	Bleeder Valve 1/4"-18 NPT w/T-Handle	2	
35	TA0-934667-0	Street Tee, 1/4"-18 NPTF Male x 1/4"-18 NPTF Female x 1/4"-18 NPT Female	1	
36	JDP4657	Hollow Hex Pipe Plug, 1/4"-18 NPT, Stainless Steel	1	

Impellicone and Mounting Hardware - 2 Section John Blue

Please visit www.unverferth.com/parts/ for the most current parts listing.

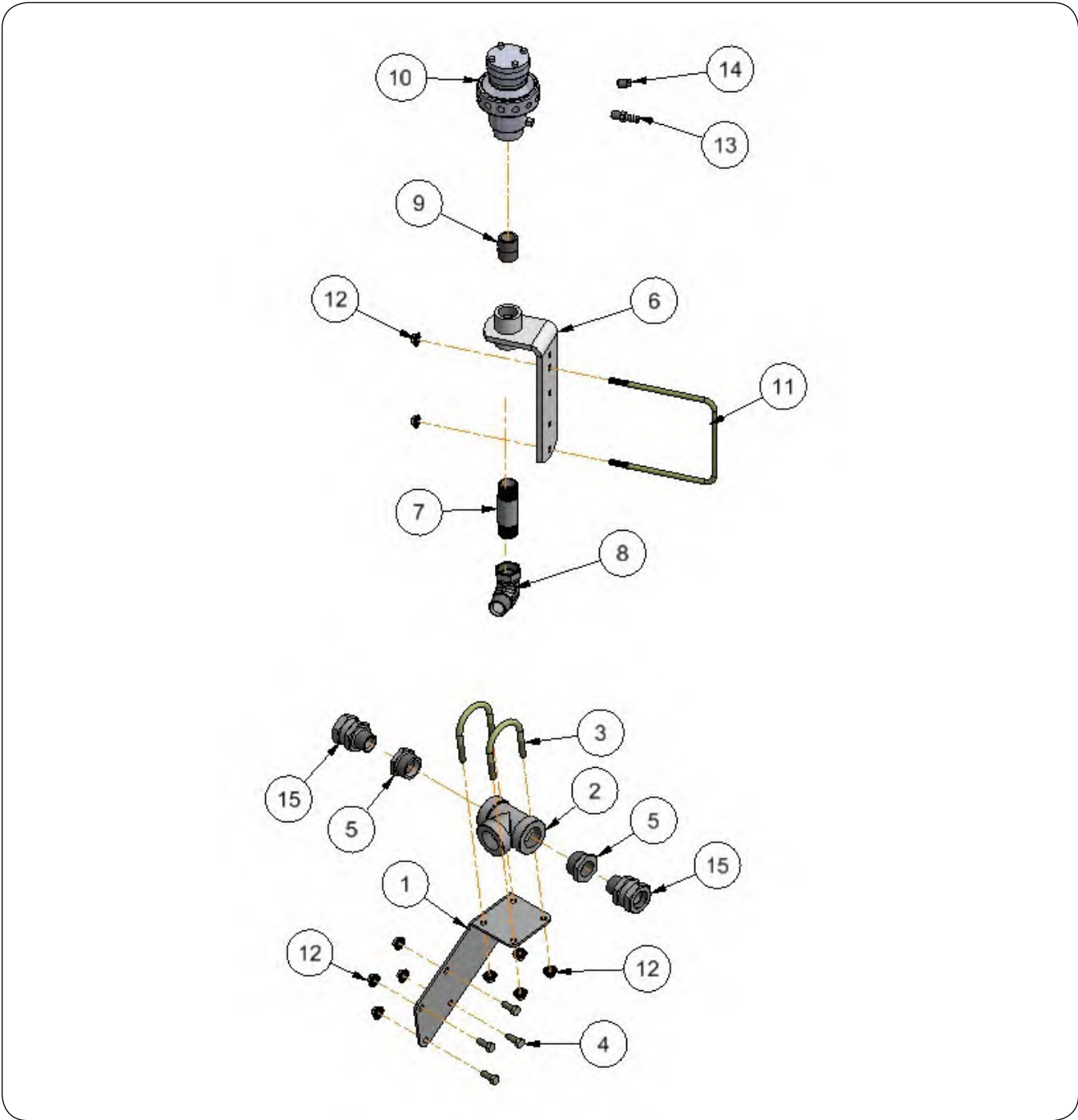

Impellicone and Mounting Hardware - 2 Section John Blue

Please visit www.unverferth.com/parts/ for the most current parts listing.

ITEM	PART NUMBER	DESCRIPTION	QTY																			
			13 ROW 30"	15 ROW 30"	16 ROW 30"	17 ROW 30"	18 ROW 20"	18 ROW 30"	19 ROW 30"	21 ROW 30"	24 ROW 20"	12 ROW 30"										
	43692	NH3 Applicator 2-Section/13-Port										1									-	
	44669	NH3 Applicator 2-Section/6-Port																				1
1	44263B	Distribution Tee Mounting Bracket =Black=																				1
2	JDP4037	Pipe Tee 1 1/4-11.5 NPT Female																				1
3	TA1-902545-0	U-Bolt, 3/8"-16UNC x 3 7/16", 2 3/4" C/C																				2
4	9390-055	Capscrew, 3/8"-16UNC x 1" G5																				4
5	JDP4046	Reducer Bushing, 1 1/4-11.5 NPT Male x 1-11.5 NPT Female																				2
6	JCM2328	Equa-Flow Mounting Bracket																				2
7	JDP4130	Nipple, 1-11.5 NPT Male x 4"																				2
8	JCP2741	90° Elbow, 1-11.5 NPT Male x 1-11.5 NPT Female																				2
9	JDP4034	Nipple, 1-11.5 NPT Male x 1 9/16"																				4
10	JCP2564	Impellicone 13 Port Flow Divider Pressure Gauge & Outlet Ports																				2
	9504212	Replacement Needle																				-
	9504213	Replacement O-Ring																				-
	9503255	Impellicone 6 Port Flow Divider Pressure Gauge & Outlet Ports																				2
	9504212	Replacement Needle																				-
	9504213	Replacement O-Ring																				-
11	JBP3214	U-Bolt, 3/8"-16UNC x 7", 4 7/16" C/C																				2
	JBP3351	U-Bolt, 3/8"-16UNC x 7", 6 7/16" C/C																				2
12	91263	Nut/Large Flange 3/8"-16UNC																				12
13	JCP2308	Hose Barb 1/4" NPT Male x 3/8" Hose Barb																				25
14	92350	Plug, 1/4"-18 NPTF Male w/Square Head																				14
15	JCP2894	Pipe Union 1-11.5 NPT Female Both Ends																				2

Impellicone and Mounting Hardware - 3 Section John Blue

Please visit www.unverferth.com/parts/ for the most current parts listing.

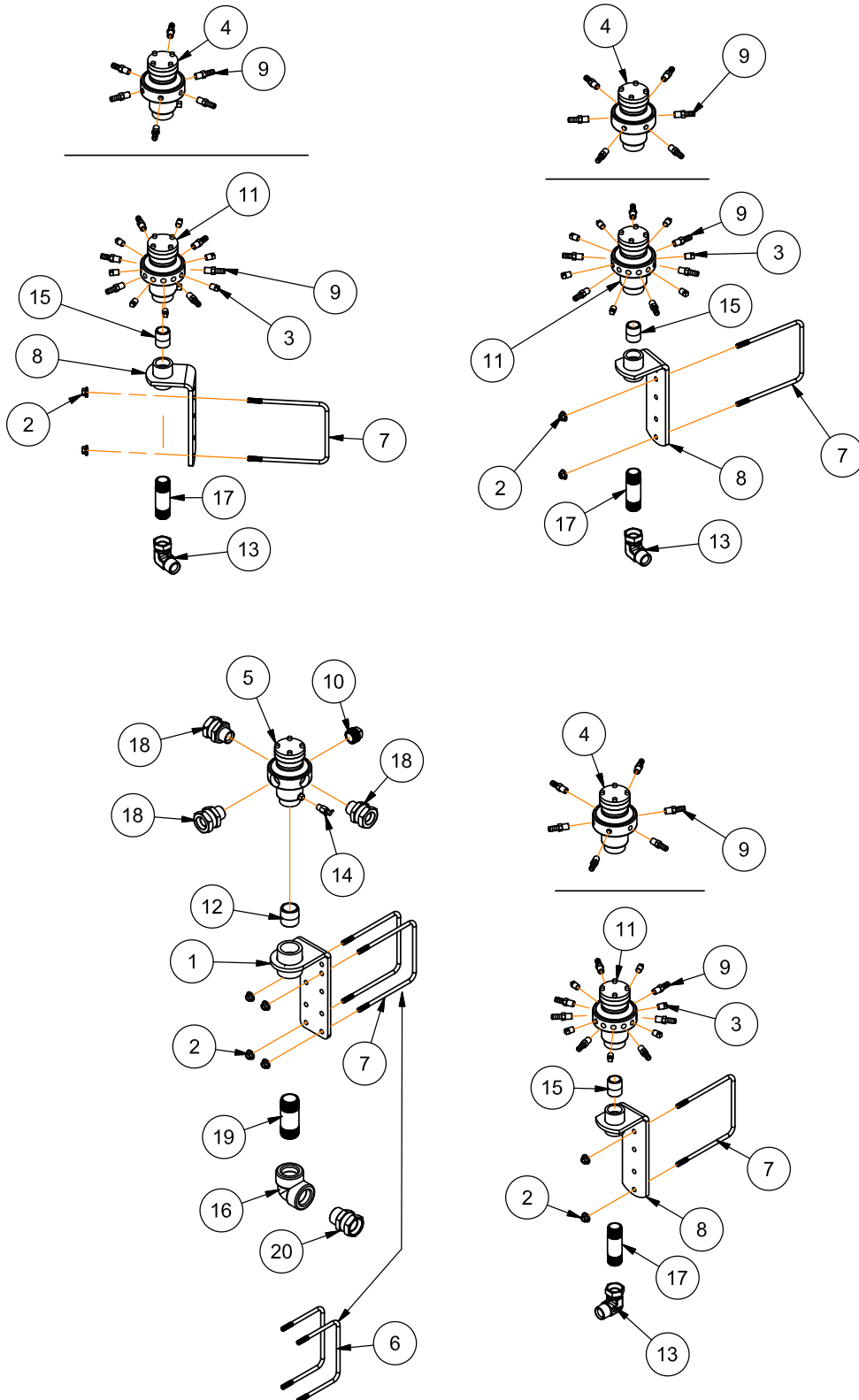

Impellicone and Mounting Hardware - 3 Section John Blue

Please visit www.unverferth.com/parts/ for the most current parts listing.

ITEM	PART NUMBER	DESCRIPTION	QTY										
			12 ROW 30"	13 ROW 30"	15 ROW 30"	16 ROW 30"	17 ROW 30"	18 ROW 20"	18 ROW 30"	19 ROW 30"	21 ROW 30"	24 ROW 20"	
	43748	NH3 Applicator 3-Section/6-Port							1				-
	43436	NH3 Applicator 3-Section/13-Port							-				1
1	44117B	Splitter Mounting Bracket Weldment =Black=							1				1
2	91263	Nut/Large Flange 3/8"-16UNC							10				10
3	92350	Plug, 1/4"-18 NPTF Male w/Square Head							4				20
4	9503255	Impellicone 6 Port Flow Divider Pressure Gauge & Outlet Ports							3				-
5	9503256	Impellicone 4 Port Splitter Outlet Ports							1				1
	9504216	Replacement Needle							-				-
	9504217	Replacement O-Ring							-				-
6	JBP3045	U-Bolt, 3/8"-16UNC x 5", 6 7/16" C/C							-				2
7	JBP3351	U-Bolt, 3/8"-16UNC x 7", 6 7/16" C/C							5				5
	JBP3214	U-Bolt, 3/8"-16UNC x 7", 4 7/16" C/C							5				-
8	JCM2328	Equa-Flow Mounting Bracket							3				3
9	JCP2308	Hose Barb 1/4" NPT Male x 3/8" Hose Barb							18				25
10	JCP2480	Screwed Plug, 1-11.5 NPT w/Square Head							1				1
11	JCP2564	Impellicone 13 Port Flow Divider Pressure Gauge & Outlet Ports							-				3
	9504212	Replacement Needle							-				-
	9504213	Replacement O-Ring							-				-
12	JCP2727	Nipple, 1 1/4-11.5 NPT Male x 1 5/8 (Close)							2				2
13	JCP2741	90° Elbow, 1-11.5 NPT Male x 1-11.5 NPT Female							3				3
14	JCP2838	Bleeder Valve 1/4-18 NPT w/T-Handle							1				1
15	JDP4034	Nipple, 1-11.5 NPT Male x 1 9/16"							3				3
16	9503720	90° Elbow, 1 1/4-11.5 NPT Female x 1 1/4-11.5 NPT Female							1				1
17	JDP4130	Nipple, 1-11.5 NPT Male x 4"							3				3
18	JDP4598	Pipe Swivel Union 1-11.5 NPT Male x 1-11.5 NPSM Female							3				3
19	9503332	Nipple, 1 1/4-11.5 NPT Male x 4							1				1
20	JCP2893	Pipe Union, 1 1/4-11.5 NPT Female Both ends							1				1

Impellicone and Mounting Hardware - 4 Section John Blue

Please visit www.unverferth.com/parts/ for the most current parts listing.

- 16 ROW 30"
- 17 ROW 30"
- 18 ROW 30"
- 19 ROW 30"
- 21 ROW 30"
- 24 ROW 20"

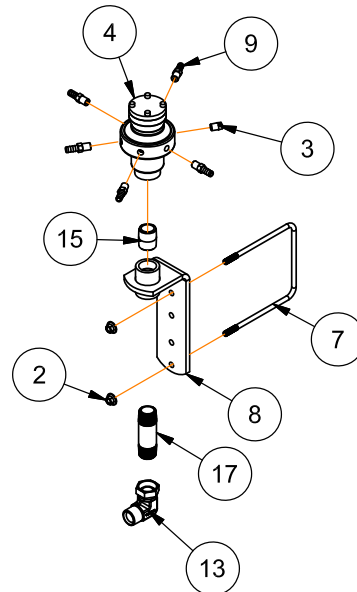
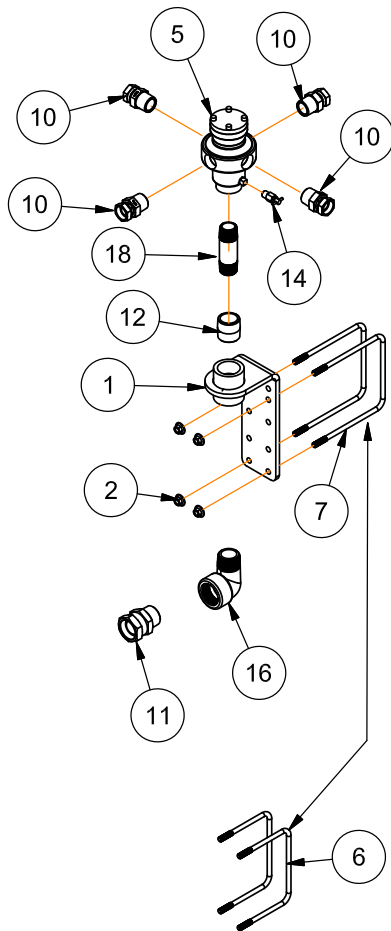
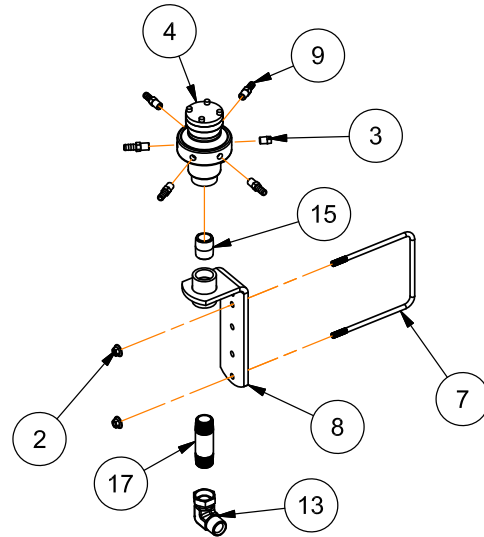
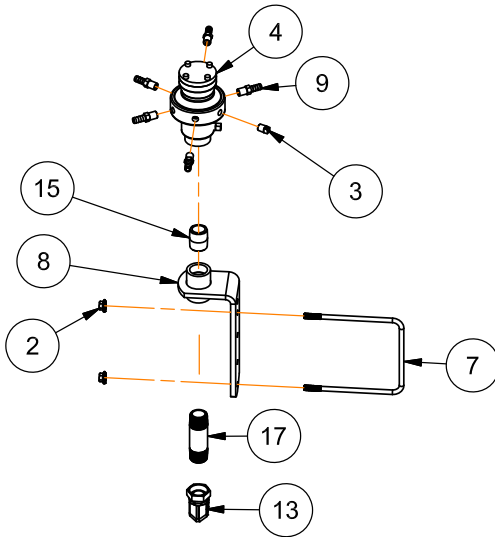

Impellicone and Mounting Hardware - 4 Section John Blue

Please visit www.unverferth.com/parts/ for the most current parts listing.

ITEM	PART NUMBER	DESCRIPTION	QTY
	43437	NH3 Applicator 4-Section/6-Port	1
1	44117B	Splitter Mounting Bracket Weldment =Black=	1
2	91263	Nut/Large Flange 3/8"-16UNC	12
3	92350	Plug, 1/4"-18 NPTF Male w/Square Head	5
4	9503255	Impellicone 6 Port Flow Divider Pressure Gauge & Outlet Ports	4
	9504212	Replacement Needle	-
	9504213	Replacement O-Ring	-
5	9503256	Impellicone 4 Port Splitter Outlet Ports	1
	9504216	Replacement Needle	-
	9504217	Replacement O-Ring	-
6	JBP3045	U-Bolt, 3/8"-16UNC x 5", 6 7/16" C/C	2
7	JBP3351	U-Bolt, 3/8"-16UNC x 7", 6 7/16" C/C	4
8	JCM2328	Equa-Flow Mounting Bracket	4
9	JCP2308	Hose Barb 1/4" NPT Male x 3/8" Hose Barb	24
10	9503611	Pipe Swivel Union 1-11.5 NPT Male x 3/4-14 NPSM Female	4
11	JCP2893	Pipe Union, 1 1/4-11.5 NPT Female Both ends	1
12	JCP2727	Nipple, 1 1/4-11.5 NPT Male x 1 5/8 (Close)	2
13	JCP2741	90° Elbow, 1-11.5 NPT Male x 1-11.5 NPT Female	4
14	JCP2838	Bleeder Valve 1/4-18 NPT w/T-Handle	1
15	JDP4034	Nipple, 1-11.5 NPT Male x 1 9/16"	4
16	9503720	90° Elbow, 1 1/4-11.5 NPT Female x 1 1/4-11.5 NPT Female	1
17	JDP4130	Nipple, 1-11.5 NPT Male x 4"	4
18	9503332	Nipple, 1 1/4-11.5 NPT Male x 4	1

Manifold and Mounting Hardware - 2 Section Continental

Please visit www.unverferth.com/parts/ for the most current parts listing.

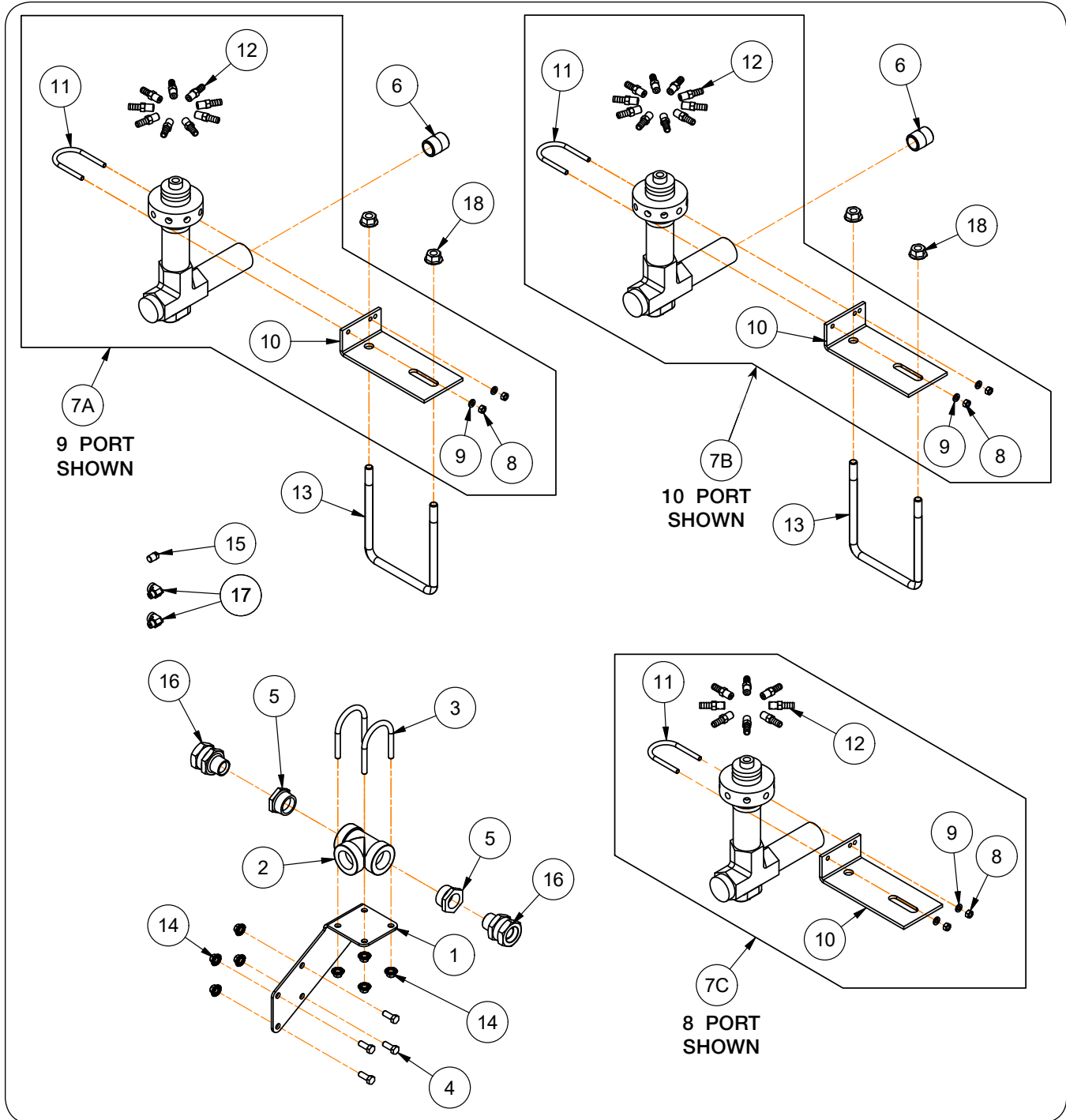

Manifold and Mounting Hardware - 2 Section Continental

Please visit www.unverferth.com/parts/ for the most current parts listing.

ITEM	PART NUMBER	DESCRIPTION	QTY					
			12 ROW 30"	13 ROW 30"	15 ROW 30" 16 ROW 30"	17 ROW 30" 18 ROW 30"	19 ROW 30"	
	45312B	NH3 Applicator 2-Section/6-Port	1	-	-	-	-	
	43419	NH3 Applicator 2-Section/7-Port	-	1	-	-	-	
	44862	NH3 Applicator 2-Section/8-Port	-	-	1	-	-	
	43749	NH3 Applicator 2-Section/9-Port	-	-	-	1	-	
	44023	NH3 Applicator 2-Section/10-Port	-	-	-	-	1	
1	44263B	Distribution Tee Mounting Bracket =Black=	1	1	1	1	1	
2	JDP4037	Pipe Tee 1 1/4-11.5 NPT Female	1	1	1	1	1	
3	TA1-902545-0	U-Bolt, 3/8"-16UNC x 3 7/16", 2 3/4" C/C	2	2	2	2	2	
4	9390-055	Capscrew, 3/8"-16UNC x 1" G5	4	4	4	4	4	
5	JDP4046	Reducer Bushing, 1 1/4-11.5 NPT Male x 1-11.5 NPT Female	2	2	2	2	2	
6	JDP4034	Nipple, 1-11.5 NPT Male x 1 9/16"	4	4	4	4	4	
7A	JCP2789	Manifold 9 Port-C (A-360) Assembly (Includes Items 8-12)	-	-	-	2	-	
	9504218	Service Repair Kit						
7B	JCP2790	Manifold 10 Port-C (A-360) Assembly (Includes Items 8-12)	-	-	-	-	2	
	9504218	Service Repair Kit						
7C	JCP2788	Manifold 8 Port-C (A-360) Assembly SHOWN (Includes Items 8-12)	-	-	2	-	-	
	9504218	Service Repair Kit						
	JCP2786	Manifold 6 Port-C (A-360) Assembly (Includes Items 8-12)	2	-	-	-	-	
	9504218	Service Repair Kit						
	JCP2787	Manifold 7 Port-C (A-360) Assembly (Includes Items 8-12)	-	2	-	-	-	
	9504218	Service Repair Kit						
8	9394-004	Hex Nut, 5/16"-18UNC	2	2	2	2	2	
9	9404-019	Lock Washer, 5/16"	2	2	2	2	2	
10	9503495	Mounting Bracket	1	1	1	1	1	
11	9503496	U-Bolt, 5/16"-18UNC x 3 13/32", 2 5/16" C/C	1	1	1	1	1	
12	9503497	Hose Barb, 1/4 NPT Male x 3/8 Hose, w/.201 Orifice	8	8	8	9	10	
13	JBP3354	U-Bolt, 5/8"-11UNC x 7 3/4", 6 11/16" C/C	2	2	2	2	2	
	JBP3099	U-Bolt, 5/8"-11UNC x 6", 6 11/16" C/C	2	2	2	2	2	
14	91263	Nut/Large Flange 3/8"-16UNC	8	8	8	8	8	
15	92350	Plug, 1/4"-18 NPTF Male w/Square Head	1	1	1	1	1	
16	JCP2894	Pipe Union 1-11.5 NPT Female Both Ends	2	2	2	2	2	
17	91432	90° Elbow, 1/4-18 NPTF	2	2	2	2	2	
18	9502324	Flange Nut, 5/8"-11UNC	4	4	4	4	4	

Manifold and Mounting Hardware - 3 Section Continental

Please visit www.unverferth.com/parts/ for the most current parts listing.

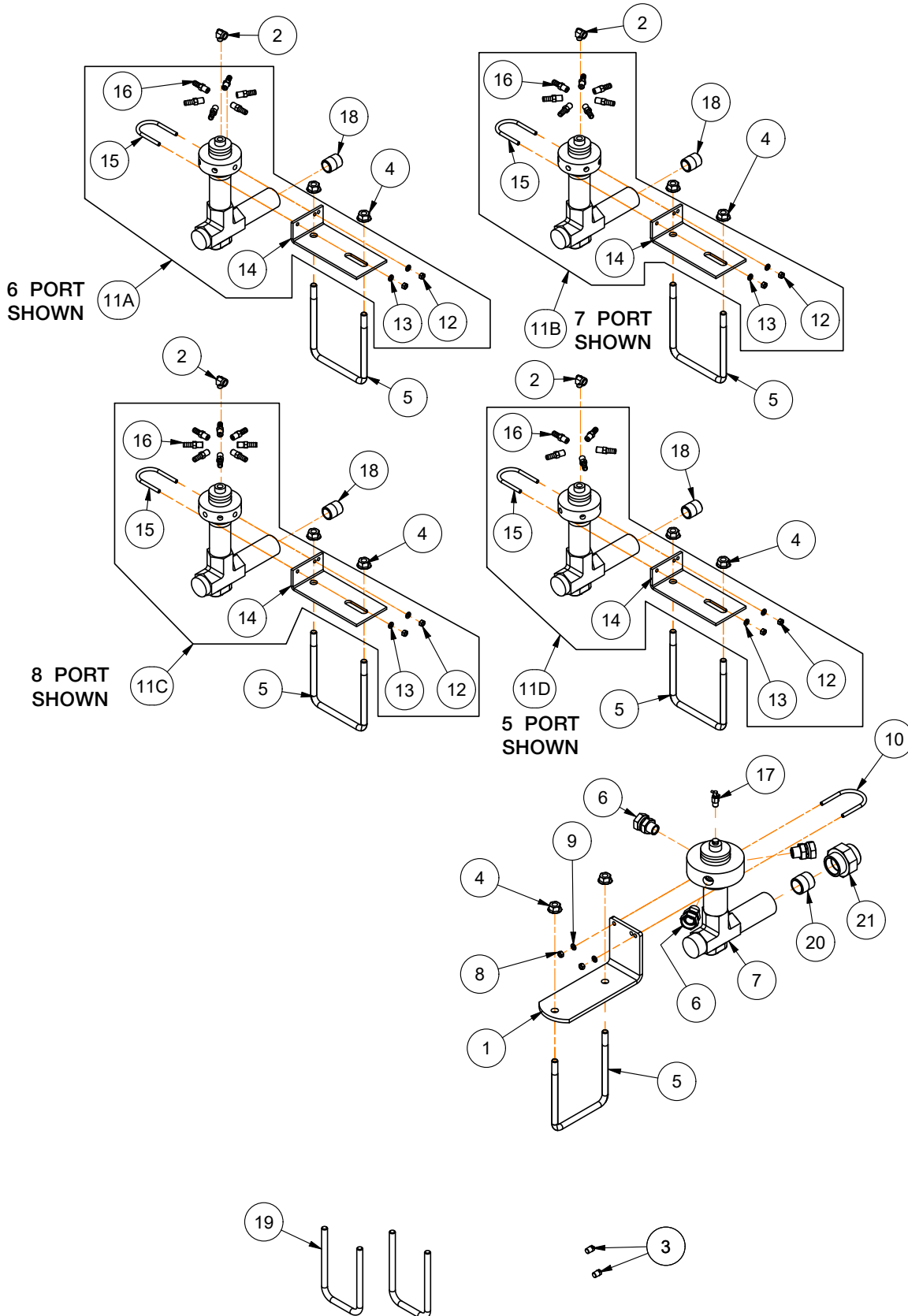

Manifold and Mounting Hardware - 3 Section Continental

Please visit www.unverferth.com/parts/ for the most current parts listing.

ITEM	PART NUMBER	DESCRIPTION	QTY								
			12 ROW 30"	13 ROW 30"	15 ROW 30"	16 ROW 30"	17 ROW 30"	18 ROW 20"	18 ROW 30"	19 ROW 30"	21 ROW 30"
	45313B	NH3 Applicator 3-Section/4-Port	1	-	-	-	-	-	-	-	-
	43750	NH3 Applicator 3-Section/5-Port	-	1	-	-	-	-	-	-	-
	43751	NH3 Applicator 3-Section/6-Port	-	-	-	1	-	-	-	-	-
	44024	NH3 Applicator 3-Section/7-Port	-	-	-	-	-	1	-	-	-
	43440	NH3 Applicator 3-Section/8-Port	-	-	-	-	-	-	-	-	1
1	44508B	Splitter Mounting Bracket	1	1	1	1	1	1	1	1	1
2	91432	90° Elbow, 1/4-18 NPTF	3	3	3	3	3	3	3	3	3
3	92350	Plug, 1/4"-18 NPTF Male w/Square Head	-	2	2	2	2	2	2	1	1
4	9502324	Flange Nut, 5/8"-11UNC	8	8	8	8	8	8	8	8	8
5	JBP3354	U-Bolt, 5/8"-11UNC x 7 3/4", 6 11/16" C/C	4	4	4	4	4	4	4	4	4
	JBP3099	U-Bolt, 5/8"-11UNC x 6", 6 11/16" C/C	4	4	4	4	4	-	-	-	-
6	JCP2740	Pipe Swivel Union, 3/4-14 NPT Male x 1-11.5 NPT Female	3	3	3	3	3	3	3	3	3
7	9504118	Manifold 3 Port Splitter Outlet Ports	1	1	1	1	1	1	1	1	1
	9504219	Service Repair Kit									
8	9394-004	Hex Nut, 5/16"-18UNC	2	2	2	2	2	2	2	2	2
9	9404-019	Lock Washer, 5/16"	2	2	2	2	2	2	2	2	2
10	9503499	U-Bolt, 5/16"-18UNC x 3 21/32", 2 13/16" C/C	1	1	1	1	1	1	1	1	1
11A	JCP2786	Manifold 6 Port-C (A-360) Assembly (Includes Items 12-16)	-	-	-	3	-	-	-	-	-
	9504218	Service Repair Kit									
11B	JCP2787	Manifold 7 Port-C (A-360) Assembly (Includes Items 12-16)	-	-	-	-	-	3	-	-	-
	9504218	Service Repair Kit									
11C	JCP2788	Manifold 8 Port-C (A-360) Assembly (Includes Items 12-16)	-	-	-	-	-	-	-	3	-
	9504218	Service Repair Kit									
11D	JCP2785	Manifold 5 Port-C (A-360) Assembly (Includes Items 12-16)	-	3	-	-	-	-	-	-	-
	9504218	Service Repair Kit									
	9503604	Manifold 4 Port-C (A-360) Assembly (Includes Items 12-16)	3	-	-	-	-	-	-	-	-
	9504218	Service Repair Kit									
12	9394-004	Hex Nut, 5/16"-18UNC	2	2	2	2	2	2	2	2	
13	9404-019	Lock Washer, 5/16"	2	2	2	2	2	2	2	2	
14	9503495	Mounting Bracket	1	1	1	1	1	1	1	1	
15	9503496	U-Bolt, 5/16"-18UNC x 3 13/32", 2 5/16" C/C	1	1	1	1	1	1	1	1	
16	9503497	Hose Barb, 1/4 NPT Male x 3/8 Hose, w/.201 Orifice	5	5	6	6	7	7	8	8	
17	JCP2838	Bleeder Valve 1/4-18 NPT w/T-Handle	1	1	1	1	1	1	1	1	
18	JDP4034	Nipple, 1-11.5 NPT Male x 1 9/16"	3	3	3	3	3	3	3	3	
19	JBP3331	U-Bolt, 5/8"-11UNC x 7 1/2", 4 11/16" C/C	-	-	-	-	-	2	2	2	
20	JCP2727	Nipple, 1 1/4-11.5 NPT Male x 1 5/8"	1	1	1	1	1	1	1	1	
21	JCP2893	Pipe Union, 1 1/4-11.5 NPT Female Both Ends	1	1	1	1	1	1	1	1	

Manifold and Mounting Hardware - 4 Section Continental

Please visit www.unverferth.com/parts/ for the most current parts listing.

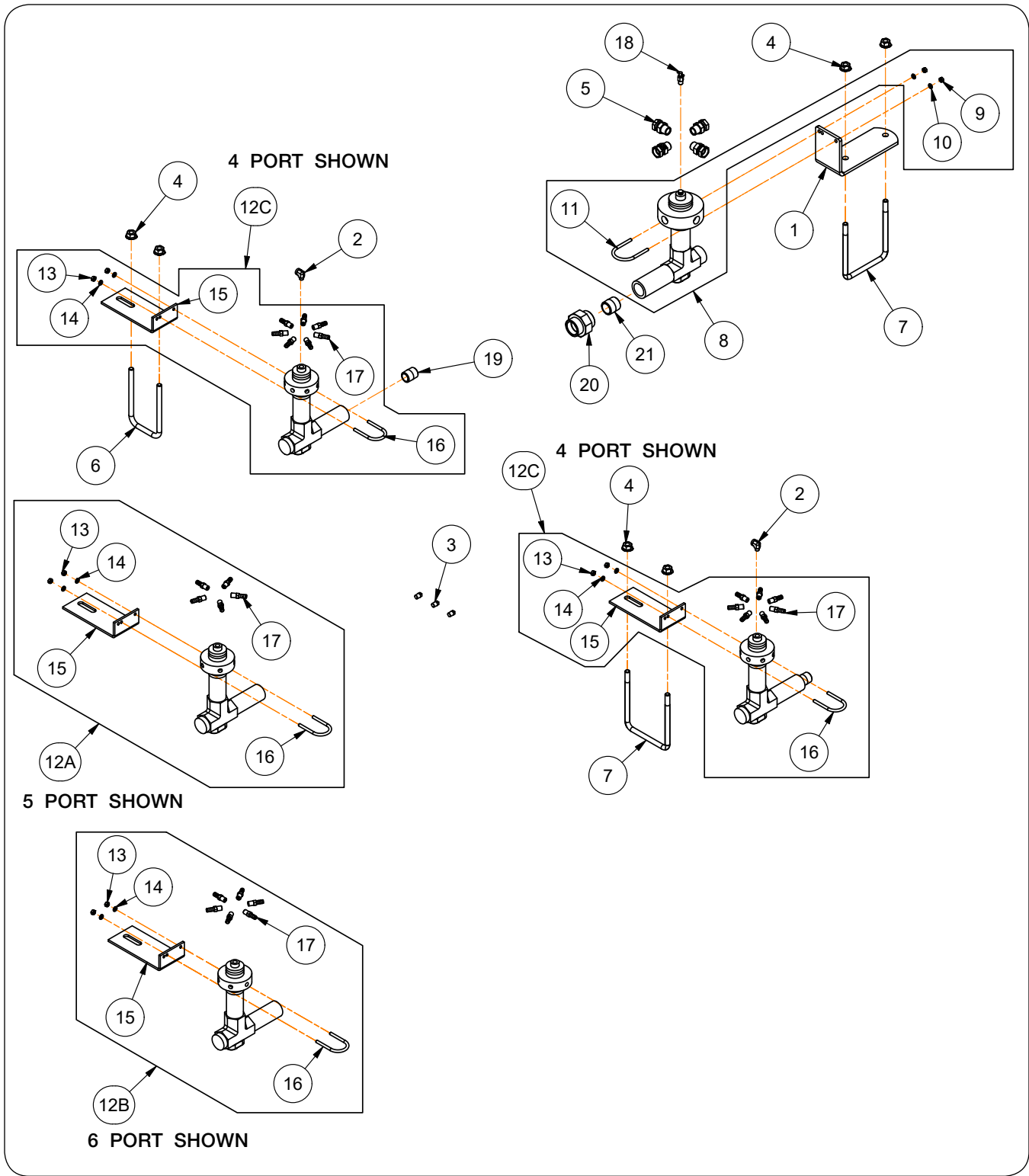

Manifold and Mounting Hardware - 4 Section Continental

Please visit www.unverferth.com/parts/ for the most current parts listing.

ITEM	PART NUMBER	DESCRIPTION	QTY				
			16 ROW 30"	17 ROW 30"	18 ROW 30"	19 ROW 30"	21 ROW 30" 24 ROW 20"
	45361B	NH3 Applicator 4-Section/4-Port	1	-	-		
	44028	NH3 Applicator 4-Section/5-Port	-	1	-		
	43441	NH3 Applicator 4-Section/6-Port	-	-	1		
1	44508B	Splitter Mounting Bracket	1	1	1		
2	91432	90° Elbow, 1/4-18 NPTF	4	4	4		
3	92350	Plug, 1/4"-18 NPTF Male w/Square Head	1	3	3		
4	9502324	Flange Nut, 5/8"-11UNC	10	10	10		
5	9503610	Pipe Swivel Union, 3/4-14 NPT Male x 3/4-14 NPSM Female	4	4	4		
6	JBP3331	U-Bolt, 5/8"-11UNC x 7 1/2", 4 11/16" C/C	2	2	2		
7	JBP3354	U-Bolt, 5/8"-11UNC x 7 3/4", 6 11/16" C/C	5	3	3		
8	9504119	Manifold 4 Port Splitter Outlet Ports	1	1	1		
	9504219	Service Repair Kit					
9	9394-004	Hex Nut, 5/16"-18UNC	2	2	2		
10	9404-019	Lock Washer, 5/16"	2	2	2		
11	9503499	U-Bolt, 5/16"-18UNC x 3 21/32", 2 13/16" C/C	1	1	1		
12A	JCP2785	Manifold 5 Port-C (A-360) Assembly (Includes Items 13-17)	-	4	-		
	9504218	Service Repair Kit					
12B	JCP2786	Manifold 6 Port-C (A-360) Assembly (Includes Items 13-17)	-	-	4		
	9504218	Service Repair Kit					
12C	9503604	Manifold 4 Port-C (A-360) Assembly (Includes Items 13-17)	4	-	-		
	9504218	Service Repair Kit					
13	9394-004	Hex Nut, 5/16"-18UNC	2	2	2		
14	9404-019	Lock Washer, 5/16"	2	2	2		
15	9503495	Mounting Bracket	1	1	1		
16	9503496	U-Bolt, 5/16"-18UNC x 3 13/32", 2 5/16" C/C	1	1	1		
17	9503497	Hose Barb, 1/4 NPT Male x 3/8 Hose, w/.201 Orifice	4	5	6		
18	JCP2838	Bleeder Valve 1/4-18 NPT w/T-Handle	1	1	1		
19	JDP4034	Nipple, 1-11.5 NPT Male x 1 9/16"	4	4	4		
20	JCP2893	Pipe Union, 1 1/4-11.5 NPT Female Both Ends	1	1	1		
21	JCP2727	Nipple, 1 1/4-11.5 NPT Male x 1 5/8"	1	1	1		

Distribution 2-Section Hoses and Electrical Components

Please visit www.unverferth.com/parts/ for the most current parts listing.

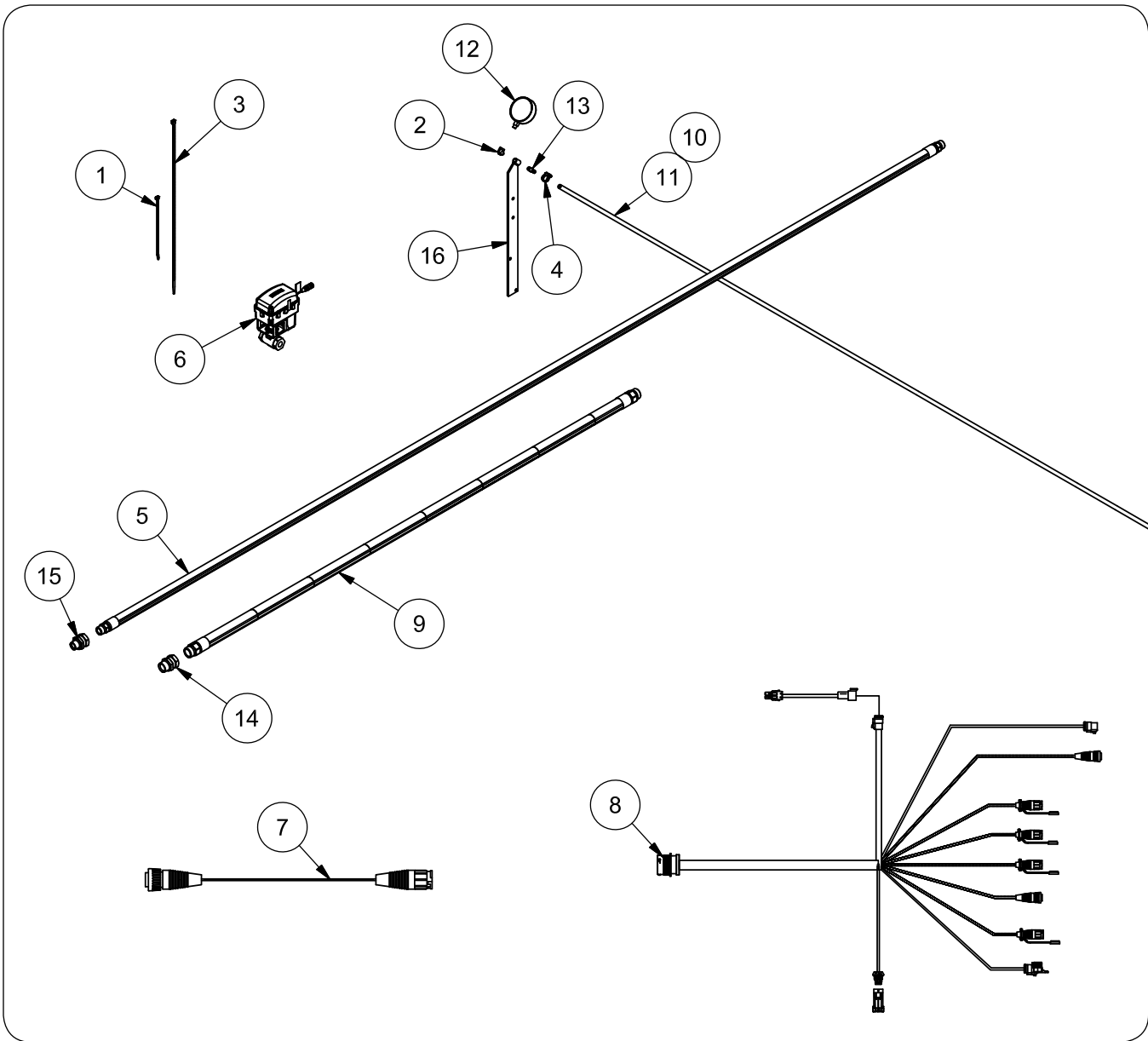

NOTE: 3/8" EVA hose comes partially pre-cut to length. Length of hose is determined by width of toolbar. Number of pre-cut sections are determined by number of rows.

Distribution 2-Section Hoses and Electrical Components

Please visit www.unverferth.com/parts/ for the most current parts listing.

ITEM	PART NUMBER	DESCRIPTION	QTY PER DISTRIBUTION SIZE				
			2-SECTION JOHN BLUE & CONTINENTAL				
			12 ROW 30" 13 ROW 30"	15 ROW 30" 16 ROW 30" 17 ROW 30"	18 ROW 20" 18 ROW 30" 19 ROW 30"	21 ROW 30"	24 ROW 20"
	46043	Manifold Hose Routing Package	1	-	-	-	-
	46046	Manifold Hose Routing Package	-	1	-	-	-
	46048	Manifold Hose Routing Package	-	-	1	-	-
	46051	Manifold Hose Routing Package	-	-	-	1	-
	46052	Manifold Hose Routing Package	-	-	-	-	1
1	9003735	Cable Tie 11"	13	17	19	25	24
2	91432	90° Street Elbow 1/4"-18 NPTF Male x 1/4"-18 NPTF Female	2	2	2	2	2
3	94038	Cable Tie 32"	8	8	8	10	12
4	94050	Hose Clamp 11-25MM	30	38	42	54	52
5	9503311	NH3 Hose, 1" x 180", 350PSI	2	2	2	2	2
6	9503343	Electric 1" NPT, ON/OFF Valve	2	2	2	2	2
7	9503393	Wire Harness 24 Ft. Extension	2	2	2	2	2
8	9503394	Wire Harness RCM Accu-Flow HP	1	1	1	1	1
9	9503599	NH3 Hose, 1 1/4" x 84", 350PSI	1	1	1	1	1
10	JCCP2561	Hose, EVA, 3/8" x 15'	13	-	-	-	-
	JCCP2562	Hose, EVA, 3/8" x 18'	-	17	-	-	24
	JCCP2563	Hose, EVA, 3/8" x 20'	-	-	19	-	-
11	JCCP2565	Hose, EVA, 3/8" x 25'	2	2	2	27	2
12	JCP2100	Gauge, 0-100 PSI, 4" Steel Case	2	2	2	2	2
13	JCP2308	Hose Barb 1/4 NPT Male x 3/8 Hose	4	4	4	4	4
14	JDP4397	Pipe Swivel Union 1 1/4-11.5 NPT	1	1	1	1	1
15	JDP4598	Pipe Swivel Union 1-11.5 NPT	2	2	2	2	2
16	JAM4528	Hose Holder Bracket	2	2	2	2	2

Distribution 3-Section Hoses and Electrical Components

Please visit www.unverferth.com/parts/ for the most current parts listing.

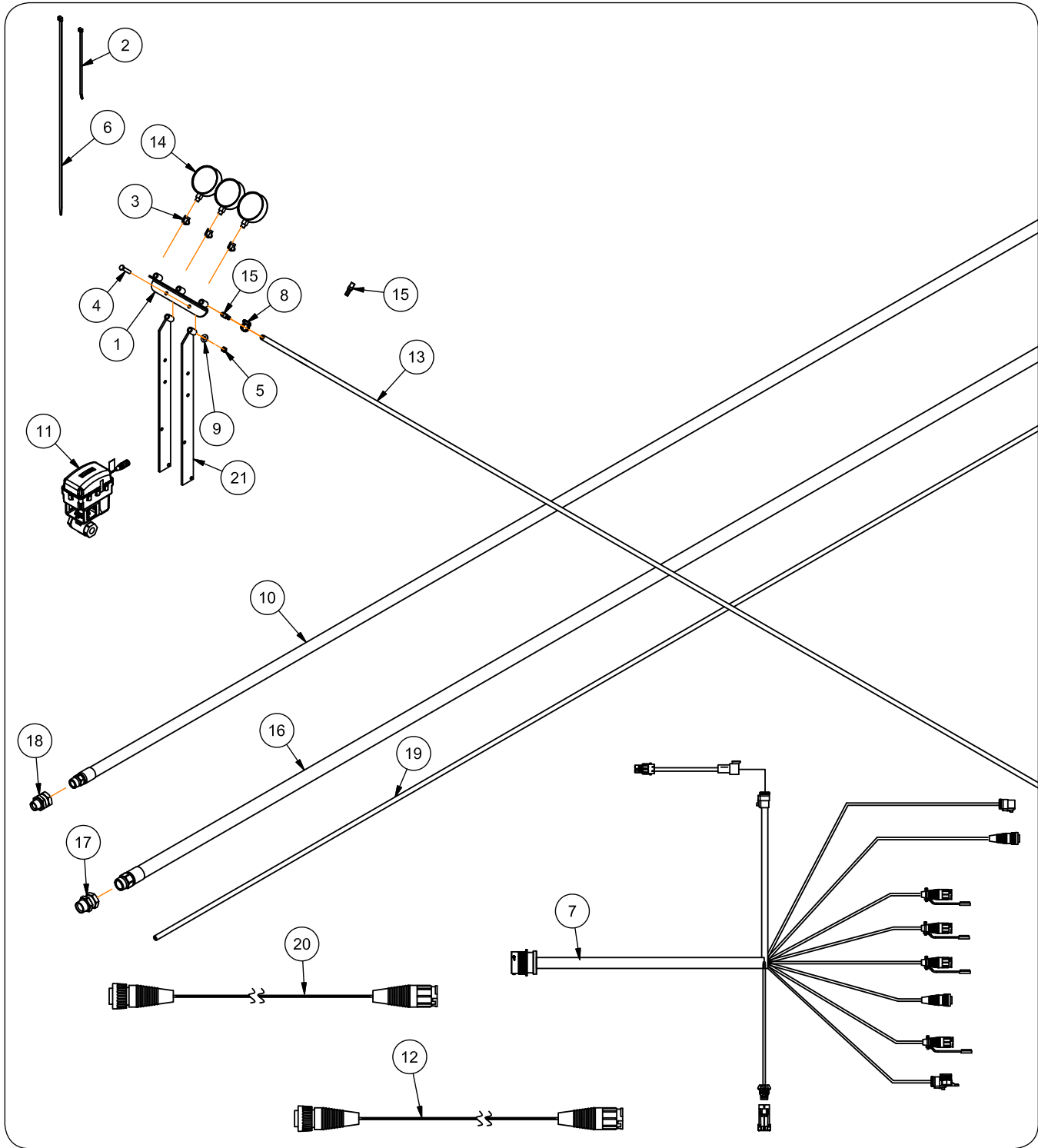

NOTE: 3/8" EVA hose comes partially pre-cut to length. Length of hose is determined by width of toolbar. Number of pre-cut sections are determined by number of rows.

Distribution 3-Section Hoses and Electrical Components

Please visit www.unverferth.com/parts/ for the most current parts listing.

ITEM	PART NUMBER	DESCRIPTION	QTY PER DISTRIBUTION SIZE				
			3-SECTION JOHN BLUE & CONTINENTAL				
			12 ROW 30" 13 ROW 30"	15 ROW 30" 16 ROW 30" 17 ROW 30"	18 ROW 20" 18 ROW 30" 19 ROW 30"	21 ROW 30"	24 ROW 20"
	46059	Manifold Hose Routing Package	1	-	-	-	-
	46061	Manifold Hose Routing Package	-	1	-	-	-
	46062	Manifold Hose Routing Package	-	-	1	-	-
	46063	Manifold Hose Routing Package	-	-	-	1	-
	46065	Manifold Hose Routing Package	-	-	-	-	1
1	44118B	Mounting Bracket - 3 Gauge Weldment	1	1	1	1	1
2	9003735	Cable Tie 11"	13	17	19	21	24
3	91432	90° Street Elbow 1/4"-18 NPTF Male x 1/4"-18 NPTF Female	3	3	3	3	3
4	9390-059	Capscrew, 3/8"-16UNC x 2" G5	2	2	2	2	2
5	9928	Lock Nut/Top, 3/8"-16UNC	2	2	2	2	2
6	94038	Cable Tie 32"	12	12	12	12	12
7	9503394	Wire Harness RCM Accu-Flow HP	1	1	1	1	1
8	94050	Hose Clamp 11-25MM	32	40	44	48	54
9	9405-076	Flat Washer, 3/8" USS	2	2	2	2	2
10	9503311	NH3 Hose, 1" x 180", 350PSI	3	-	-	-	3
	9503313	NH3 Hose, 1" x 216", 350PSI	-	3	3	-	-
	9503314	NH3 Hose, 1" x 300", 350PSI	-	-	-	3	-
11	9503343	Electric 1" NPT, ON/OFF Valve	3	3	3	3	3
12	9503393	Wire Harness 24 Ft. Extension	2	2	2	2	2
13	JCCP2565	Hose, EVA, 3/8" x 25'	3	3	-	1	3
	JCCP2566	Hose, EVA, 3/8" x 27'	-	-	3	-	-
	JCCP2567	Hose, EVA, 3/8" x 33'	-	-	-	2	-
14	JCP2100	Gauge, 0-100 PSI, 4" Steel Case	3	3	3	3	3
15	JCP2308	Hose Barb 1/4 NPT Male x 3/8 Hose	6	6	6	6	6
16	9504112	NH3 Hose, 1 1/4" x 156", 350PSI	1	1	1	1	1
17	JDP4397	Pipe Swivel Union 1 1/4-11.5 NPT	1	1	1	1	1
18	JDP4598	Pipe Swivel Union 1-11.5 NPT	3	3	3	3	3
19	JCCP2561	Hose, EVA, 3/8" x 15'	13	-	-	-	24
	JCCP2562	Hose, EVA, 3/8" x 18'	-	17	19	21	-
20	9503392	Wire Harness 12 Ft. Extension	1	1	3	3	1
21	JAM4528	Hose Holder Bracket	2	2	2	2	2

Distribution 4-Section Hoses and Electrical Components

Please visit www.unverferth.com/parts/ for the most current parts listing.

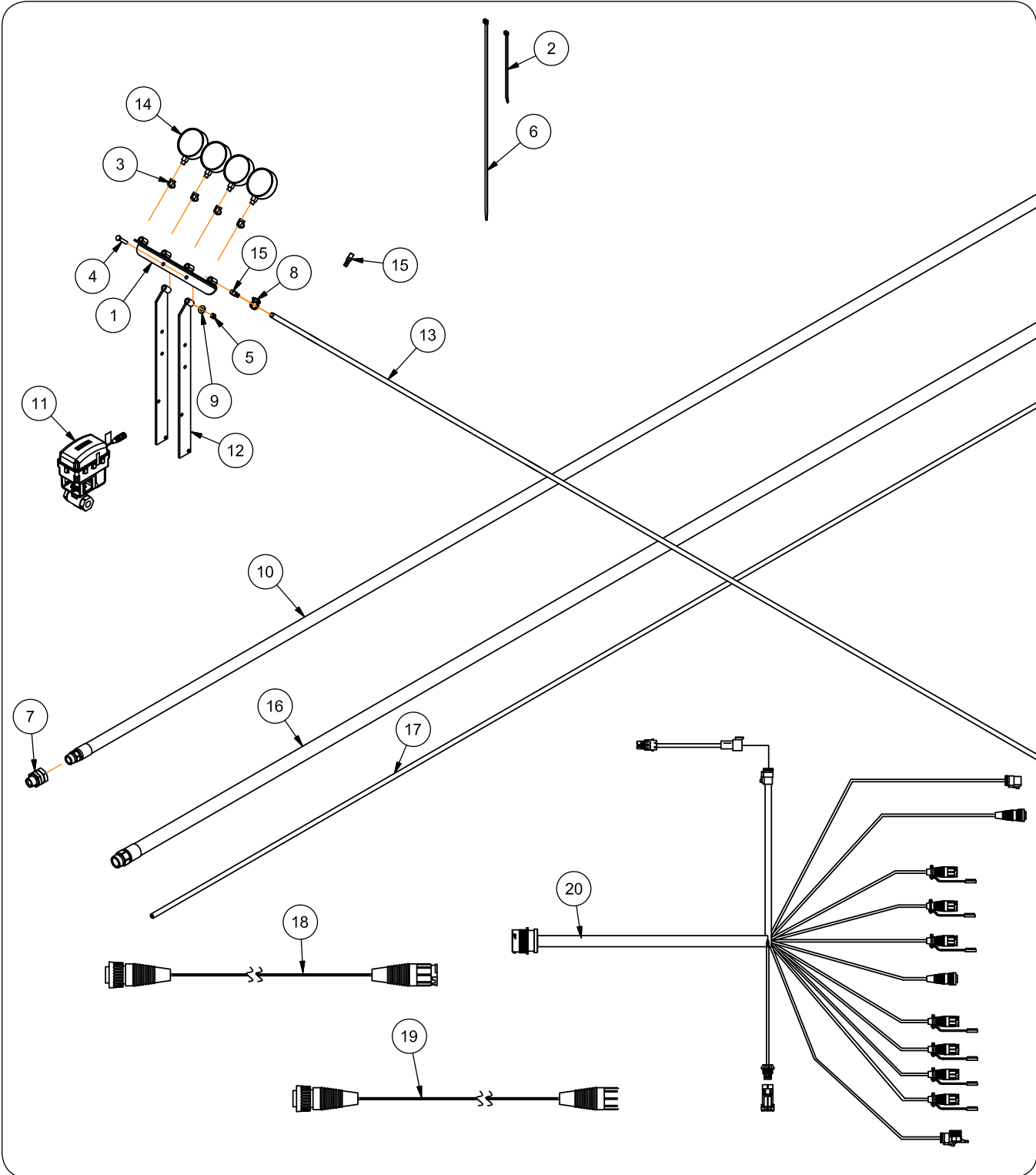

NOTE: 3/8" EVA hose comes partially pre-cut to length. Length of hose is determined by width of toolbar. Number of pre-cut sections are determined by number of rows.

Distribution 4-Section Hoses and Electrical Components

Please visit www.unverferth.com/parts/ for the most current parts listing.

ITEM	PART NUMBER	DESCRIPTION	QTY PER DISTRIBUTION SIZE				
			4-SECTION JOHN BLUE & CONTINENTAL				
			16 ROW 30"	17 ROW 30" 18 ROW 30" 19 ROW 30" 21 ROW 30"	24 ROW 20"		
	46069	Manifold Hose Routing Package	1	-	-		
	46070	Manifold Hose Routing Package	-	1	-		
	46071	Manifold Hose Routing Package	-	-	1		
1	44119B	Mounting Bracket - 4 Gauge Weldment	1	1	1		
2	9003735	Cable Tie 11"	16	17	24		
3	91432	90° Street Elbow 1/4"-18 NPTF Male x 1/4"-18 NPTF Female	4	4	4		
4	9390-059	Capscrew, 3/8"-16UNC x 2" G5	2	2	2		
5	9928	Lock Nut, 3/8"-16UNC	2	2	2		
6	94038	Cable Tie 32"	16	16	16		
7	9503611	Pipe Swivel Union 1-11.5 NPT	4	4	4		
8	94050	Hose Clamp 11-25MM	40	42	56		
9	9405-076	Flat Washer, 3/8" USS	2	2	2		
10	9503316	NH3 Hose, 3/4" x 216", 350PSI	4	-	4		
	9503317	NH3 Hose, 3/4" x 300", 350PSI	-	4	-		
11	9503343	Electric 1" NPT, ON/OFF Valve	4	4	4		
12	JAM4528	Hose Holder Bracket	2	2	2		
13	JCCP2565	Hose, EVA, 3/8" x 300"	4	2	4		
	JCCP2572	Hose, EVA, 3/8" x 504"	-	2	-		
14	JCP2100	Gauge, 0-100 PSI, 4" Steel Case	4	4	4		
15	JCP2308	Hose Barb 1/4 NPT Male x 3/8 Hose	8	8	8		
16	9504112	NH3 Hose, 1 1/4" x 156", 350PSI	1	1	1		
17	JCCP2562	Hose, EVA, 3/8" x 216"	16	23	24		
18	9503392	Wire Harness 12 Ft. Extension	3	2	3		
19	9503393	Wire Harness 24 Ft. Extension	2	4	2		
20	9503389	Wire Harness, RCM Accuflow HP	1	1	1		

1.5" Flow Control Valve

Please visit www.unverferth.com/parts/ for the most current parts listing.

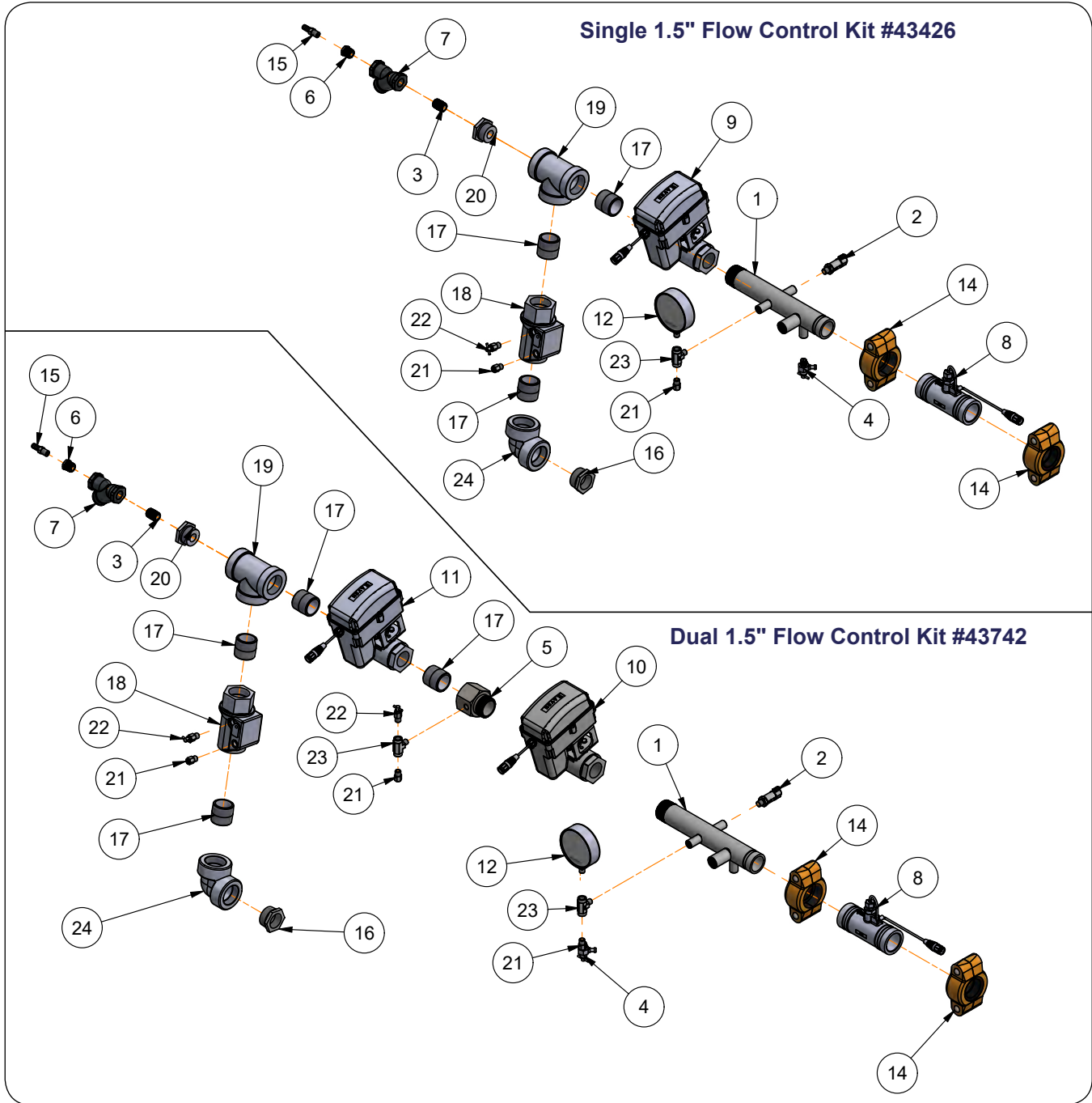

1.5” Flow Control Valve

Please visit www.unverferth.com/parts/ for the most current parts listing.

ITEM	PART NUMBER	DESCRIPTION	Single 1.5” Flow Control Kit #43426	Dual 1.5” Flow Control Kit #43742
1	9503297	Gauge Tree Manifold Weldment	1	1
2	9503299	Pressure Transducer 1-5 Volt, 0-250 PSI	1	1
3	9503333	Pipe Nipple 1/2” x 1 1/2” (Close)	1	1
4	9503335	Bleeder Valve 1/4-18 NPT w/T-Handle	1	1
5	9503337	Pipe Adapter Bleeder & Gauge	-	1
6	9503338	Reducer Bushing, 1/2-14NPT Male x 1/4-18 NPT Female	1	1
7	9503339	NH3 Strainer “Y”, 1/2-14 NPT, 60 Mesh Screen	1	1
	9504222	Service Gasket - 1/2” NH3 Strainer Cap	-	-
8	9503349	NH3 Flow Meter RFM 60SG	1	1
9	9503350	NH3 Electric 1 1/2” NPT Fast Valve Regulating	1	-
10	9503351	NH3 Electric 1 1/2” NPT, Control Valve	-	1
11	9503352	NH3 Electric 1 1/2” NPT, On/Off Valve	-	1
12	9503354	NH3 Pressure Gauge, 0-400 PSI	1	1
13	9503384	NH3 Vapor Sensor	1	-
14	9503827	Coupling 2” x 1 1/2” Gruvlok, Reducing	2	2
15	JCP2308	Hose Barb 1/4 NPT Male x 3/8 Hose	1	1
16	JCP2584	Reducer Bushing, 1 1/2-11.5 NPT Male x 1 1/4-11.5 NPT Female	1	1
17	JCP2728	Nipple 1 1/2-11.5 NPT Male x 1 3/4 (Close)	2	3
18	JCP2736	Back Check Valve 1 1/2 Full Port Swing Valve 1 1/2-11.5 NPT Female Inlet/Outlet	1	1
19	JCP2738	Pipe Tee 1 1/2-11.5 NPT Female	1	1
20	JCP2739	Reducer Bushing, 1 1/2-11.5 NPT Male x 1/2-14 NPT Female	1	1
21	JCP2837	Hydrostatic Relief Valve, Set @ 350 PSI	2	3
22	JCP2838	Bleeder Valve 1/4-18 NPT w/T-Handle	1	2
23	TA0-904640-0	Tee 1/4-18 NPTF Female x 1/4-18 NPTF Female x 1/4-18 NPTF Male	2	3
24	JCP2726	90° Elbow, 1 1/2”	1	1

1.0" Flow Control Valve (Optional)

Please visit www.unverferth.com/parts/ for the most current parts listing.

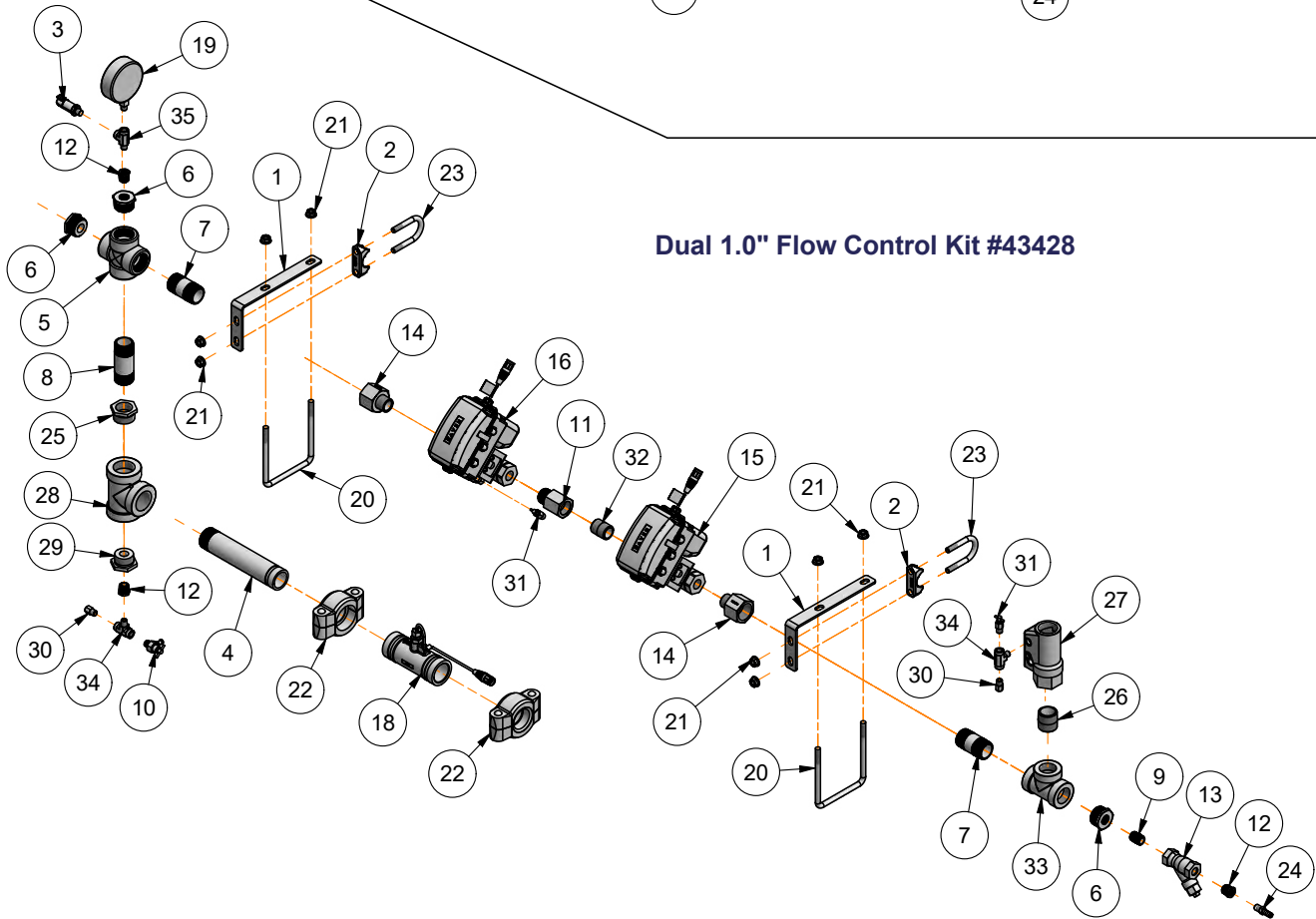
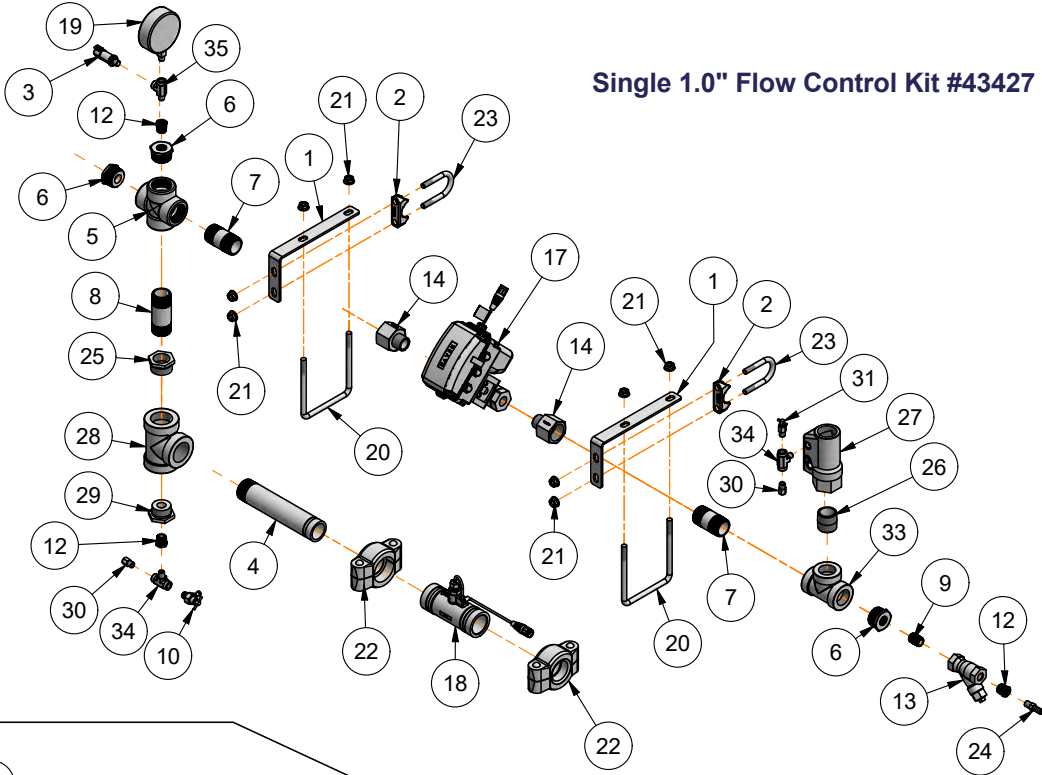

1.0” Flow Control Valve (Optional)

Please visit www.unverferth.com/parts/ for the most current parts listing.

ITEM	PART NUMBER	DESCRIPTION	Single 1.0” Flow Control Kit #43427	Dual 1.0” Flow Control Kit #43428
1	44638B	Support Bracket	2	2
2	84735B	Clamp Casting	2	2
3	9503299	Pressure Transducer 1-5 Volt, 0-250 PSI	1	1
4	9503327	Pipe Nipple 1 1/2” x 9”	1	1
5	9503328	Pipe Cross 1 1/4-11.5 NPT Female	1	1
6	9503329	Reducer Bushing, 1 1/4-11.5 NPT Male x 1/2-14 NPT Female	3	3
7	9503330	Pipe Nipple 1 1/4” x 3” (Thread Both Ends)	2	2
8	9503332	Pipe Nipple 1 1/4” x 4” (Thread Both Ends)	1	1
9	9503333	Pipe Nipple 1/2” x 1 1/2” (Close)	1	1
10	9503335	Bleeder Valve 1/4-18 NPT w/T-Handle	1	1
11	9503336	Pipe Adapter Bleeder & Gauge	-	1
12	9503338	Reducer Bushing, 1/2-14NPT Male x 1/4-18 NPT Female	3	3
13	9503339	NH3 Strainer “Y”, 1/2-14 NPT, 60 Mesh Screen	1	1
	9504222	Service Gasket - 1/2” NH3 Strainer Cap	-	-
14	9503340	Pipe Adapter Expanding, 1-11.5NPT Male x 1 1/4-11.5 NPT Female	2	2
15	9503343	NH3 Electric 1” NPT, On/Off Valve	-	1
16	9503344	NH3 Electric 1” NPT, Control Valve	-	1
17	9503345	NH3 Electric 1” NPT Fast Valve Regulating	1	-
18	9503349	NH3 Flow Meter RFM 60SG	1	1
19	9503354	NH3 Pressure Gauge, 0-400 PSI	1	1
20	9503358	U-Bolt, 7/16”-14UNC x 6”, 5 1/2” C/C	2	2
21	9503359	Flange Nut, 7/16”-14UNC	8	8
22	9503827	Coupling 2” x 1 1/2” Gruvlok, Reducing	2	2
23	95914	U-Bolt, 7/16”-14UNC x 3.12”, 2.12” C/C	2	2
24	JCP2308	Hose Barb 1/4 NPT Male x 3/8 Hose	1	1
25	JCP2584	Reducer Bushing, 1 1/2-11.5 NPT Male x 1 1/4-11.5 NPT Female	1	1
26	JCP2727	Nipple 1 1/4-11.5 NPT Male x 1 5/8 (Close)	1	1
27	JCP2735	Back Check Valve 1 1/4 Full Port Swing Valve 1 1/4-11.5 NPT Female Inlet/Outlet	1	1
28	JCP2738	Pipe Tee 1 1/2-11.5 NPT Female	1	1
29	JCP2739	Reducer Bushing, 1 1/2-11.5 NPT Male x 1/2-14 NPT Female	1	1
30	JCP2837	Hydrostatic Relief Valve, Set @ 350 PSI	2	3
31	JCP2838	Bleeder Valve 1/4-18 NPT w/T-Handle	1	2
32	JDP4034	Nipple 1-11.5 NPT Male x 1 9/16” (Close)	-	1
33	JDP4037	Pipe Tee 1 1/4-11.5 NPT Female	1	1
34	TA0-904640-0	Tee 1/4-18 NPTF Female x 1/4-18 NPTF Female x 1/4-18 NPTF Male	2	3
35	TA0-934667-0	Street Tee 4MPT-4FPT-4FPT	1	1

Cooler - Vortex

Please visit www.unverferth.com/parts/ for the most current parts listing.

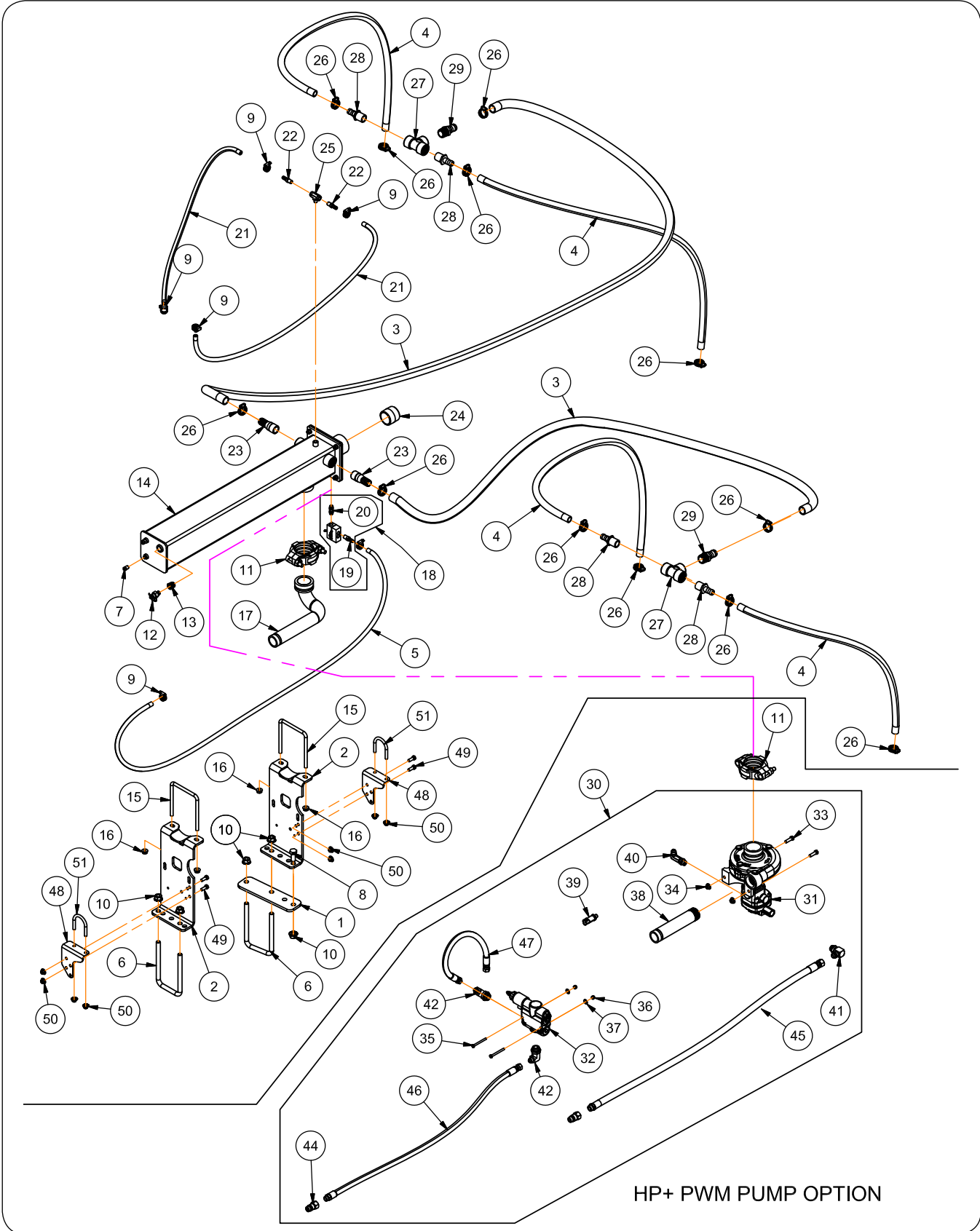

Cooler - Vortex

Please visit www.unverferth.com/parts/ for the most current parts listing.

ITEM	PART NUMBER	DESCRIPTION	50 GPM Cooler Kit #43701	80 GPM Cooler Kit #43429
1	44241B	Mounting Plate	1	1
2	46126B	Mounting Bracket	2	2
3	44460	EVA Tubing, 1.31" OD x 1.0" ID x 180", Reinforced	2	2
4	44461	EVA Tubing, 1.0" OD x 3/4" ID x 96", Non-Reinforced	4	4
5	44462	EVA Tubing, 0.63" OD x 3/8" ID x 84", Non-Reinforced	1	1
6	9002068	U-Bolt, 5/8"-11UNC x 7 1/2", 4 11/16" C/C	2	2
7	92350	Plug, 1/4-18 NPTF Male, Square Head	1	-
8	9390-122	Capscrew, 5/8"-11UNC x 1 1/2" G5	1	1
9	94050	Hose Clamp 11-25MM (Size 08)	6	6
10	9502324	Flange Nut, 5/8"-11UNC G5	5	5
11	9503296	Coupling 2 1/2 Gruviok, Flexible w/EDPM Gasket & Hdw	1	1
12	9503335	Bleeder Valve 1/4-18 NPT w/T-Handle	1	1
13	9503338	Reducer Bushing, 1/2-14NPT Male x 1/4-18 NPT Female	1	1
14	9503348	NH3 Vortex Cooler, Working Pressure 250 PSI	1	1
	9504225	Vortex Cooler, Seal/Hardware Kit	-	-
15	9503358	U-Bolt, 7/16"-14UNC x 6", 5 1/2" C/C	2	2
16	9503359	Flange Nut, 7/16"-14UNC	4	4
17	9503363	Outlet Manifold Weldment	1	-
18	9503373	Adjustable Orifice Valve 1/4-18 NPT	1	1
	9504221	Orifice Valve O-Ring Repair Kit	-	-
19	JCP2308	Hose Barb 1/4 NPT Male x 3/8 Hose	1	1
20	9503429	Pipe Nipple, 1/4" x 1 1/2" (Threaded Both Ends)	1	1
21	JCCP2569	EVA Tubing, 0.63" OD x 3/8" ID x 4", Non-Reinforced	2	2
22	JCP2308	Hose Barb 1/4 NPT Male x 3/8 Hose	2	2
23	JCP2310	Hose Barb 1", 1-11.5 NPT	2	2
24	JCP2729	Nipple, 2-11.5 NPT Male x 2 (Close)	1	1
25	TA0-904640-0	Tee 1/4-18 NPTF (Female x Female x Male)	1	1
26	TA800912	Hose Clamp 13/16"-1 1/2"	12	12
27	TA814782	Tee Poly 1-11 1/2 NPTF (Female x Female x Female)	2	2
28	TA814865	Hose Barb 1-11.5 MPT x 3/4 HS	4	4
29	TA814866	Hose Barb 1-11 1/2 MPT x 1 HS	2	2
30	9503295	Pump Upgrade Kit	-	1
31	9503355	NH3 HP+ Boost Pump & Hydraulic Motor	-	1
	9504226	Seal Kit (Hydraulic Motor)	-	-
	9504227	Seal Kit (Boost Pump)	-	-
32	9503490	Hydraulic PWM Control Valve, 10GPM	-	1
33	9390-056	Capscrew, 3/8"-16UNC x 1 1/4" G5	-	2
34	91263	Nut/Large Flange, 3/8"-16UNC	-	2
35	900900-012	Capscrew, 1/4"-20UNC x 2 3/4" (Stainless Steel)	-	2
36	900905-007	Elastic Stop Nut, 1/4"-20UNC (Stainless Steel)	-	2
37	900902-032	Flat Washer, 1/4" USS (Stainless Steel)	-	2
38	9503327	Pipe Nipple 1 1/2" x 9" (Stainless Steel)	-	1
39	9503299	Pressure Transducer 1-5 Volt, 0-250 PSI	-	1
40	901568	90° Elbow Extra Long, 3/4-16 JIC Male x 3/4-16 Male O-Ring	-	1
41	95540	90° Elbow, 7/8-14 JIC Male x 7/8-14 O-Ring Male	-	1
42	98218	90° Elbow, 3/4-16 JIC Male x 1 1/16-12 O-Ring Male	-	2
43	95477	Pioneer Male Tip, SAE 7/8-14 Female O-Ring	-	1
44	91383	Male Tip Coupling 3/4-16 O-Ring Female	-	1
45	9503491	Hose 5/8" Dia. x 192", 7/8-14 JIC Female x 7/8-14 O-Ring Male	-	1
46	9503492	Hose 1/2" Dia. x 194", 3/4-16 JIC Female x 3/4-16 O-Ring Male	-	1
47	9503493	Hose 1/2" Dia. x 22", 3/4-16 JIC Female x 3/4-16 JIC Female	-	1
48	44275B	Flow Control Support Plate	2	2
49	9390-055	Capscrew, 3/8"-16UNC x 1" G5	4	4
50	91263	Large Flange Nut, 3/8"-16UNC	8	8
51	9503416	U-Bolt, 3/8"-16UNC x 2 7/8", 2 1/2" C/C	2	2

Cooler - Continental (Optional)

Please visit www.unverferth.com/parts/ for the most current parts listing.

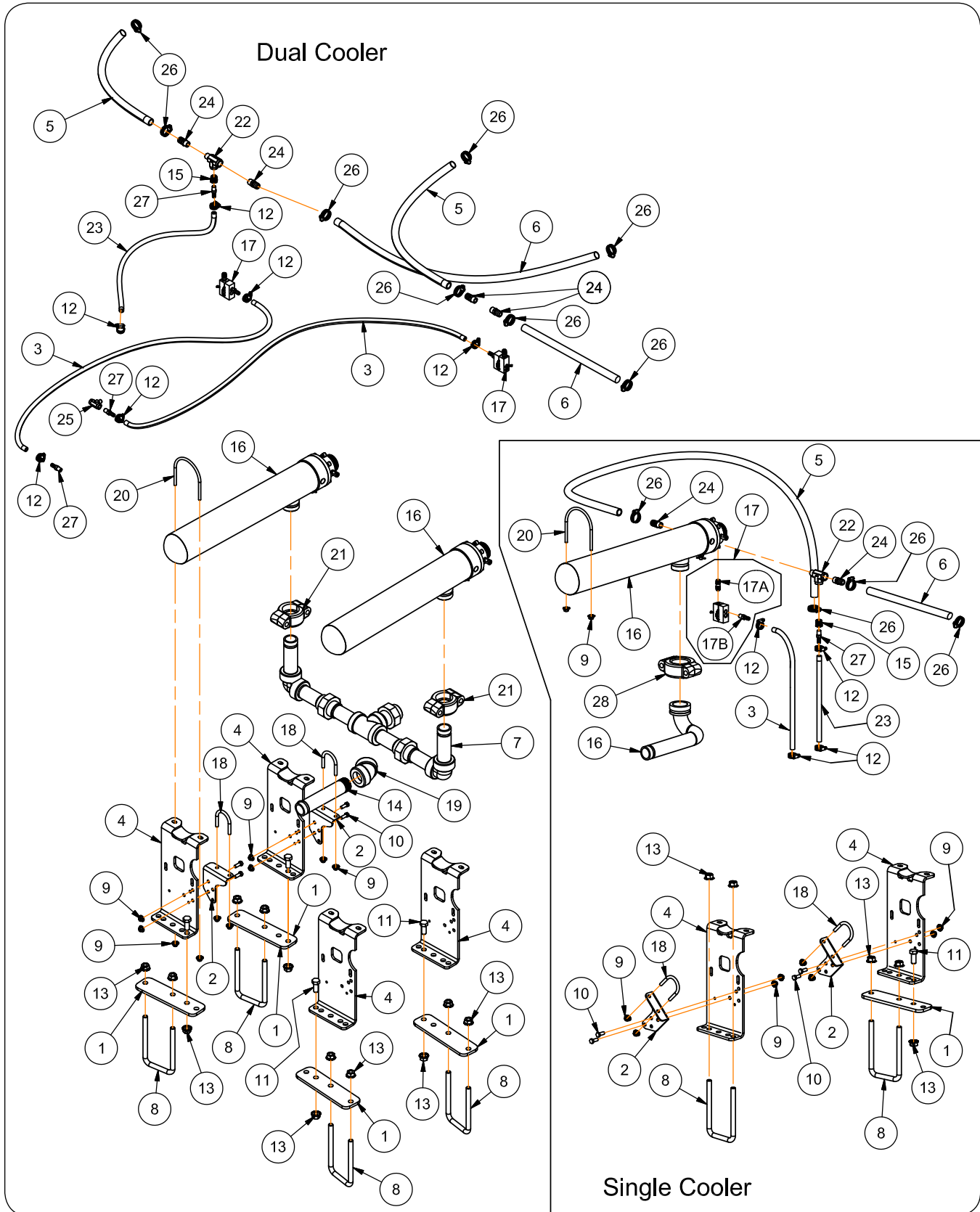

Cooler - Continental (Optional)

Please visit www.unverferth.com/parts/ for the most current parts listing.

ITEM	PART NUMBER	DESCRIPTION	Single Cooler Kit #43424	Dual Cooler Kit #43425
1	44241B	Mounting Plate	1	4
2	44275B	Flow Control Support Plate	2	2
3	44462	EVA Tubing, 0.59" OD x 3/8" ID x 84"	1	2
4	46126B	NH3 Cooler Mounting Bracket Weldment	2	4
5	46661	EVA Tubing, 1" OD x 3/4" ID x 240"	1	2
6	46662	EVA Tubing, 1" OD x 3/4" ID x 288"	1	2
7	46773B	Dual Cooler Discharge Plumbing Assembly, 1 1/2" Connections	-	1
8	9002068	U-Bolt, 5/8"-11UNC x 7 1/2", 4 11/16" C/C	2	4
9	91263	Large Flange Nut, 3/8"-16UNC	12	16
10	9390-055	Capscrew, 3/8"-16UNC x 1" G5	4	4
11	9390-122	Capscrew, 5/8"-11UNC x 1 1/2" G5	1	4
12	94050	Hose Clamp 11-25MM (Size 08)	4	6
13	9502324	Flange Nut, 5/8"-11UNC G5	5	12
14	9503327	Pipe Nipple, 1 1/2" x 9" (Stainless Steel)	-	1
15	9503338	Reducer Bushing, 1/2-14NPT Male x 1/4-18 NPT Female	1	1
16	9503361	NH3 Superflow Heat Exchanger, 2" NPT Inlet, 2" Victaulic Outlet	1	2
	9504220	Superflow Cooler Repair Kit	-	-
17	9503373	Adjustable Orifice Valve 1/4-18 NPT	1	2
	9504221	Orifice Valve O-Ring Repair Kit	-	-
17A	9503429	Pipe Nipple, 1/4" x 1 1/2" (Threaded Both Ends)	-	-
17B	JCP2308	Hose Barb 1/4 NPT Male x 3/8 Hose	-	-
18	9503416	U-Bolt, 3/8"-16UNC x 2 7/8", 2 1/2" C/C	2	2
19	9503479	45° Elbow, 1 1/2-11.5 NPT Female x 1 1/2-11.5 NPT Female	-	1
20	9503652	U-Bolt, 3/8"-16UNC x 5 5/16", 4 7/8" C/C	2	4
21	9503827	Reducing Coupling, 2 x 1 1/2	-	2
22	9659	Tee 1/2-14 NPTF (Male x Female x Female)	1	1
23	JCCP2569	EVA Tubing, 0.63" OD x 3/8" ID x 4", Non-Reinforced	1	1
24	JCP2874	Hose Barb 1/2 NPT Male x 3/4 Hose	2	4
25	TA0-904640-0	Tee 1/4-18 NPTF (Female x Female x Male)	-	1
26	TA800912	Hose Clamp 13/16"-1 1/2"	4	8
27	JCP2308	Hose Bar, 1/4 NPT Male x 3/8 Hose	1	3
28	9503334	Reducing Coupling 2 1/2 x 2 Gruvlok w/EDPM Gasket & Hardware	1	-
29	9503363	Outlet Manifold Weldment	1	-

ISOBUS Rate Controller

Please visit www.unverferth.com/parts/ for the most current parts listing.

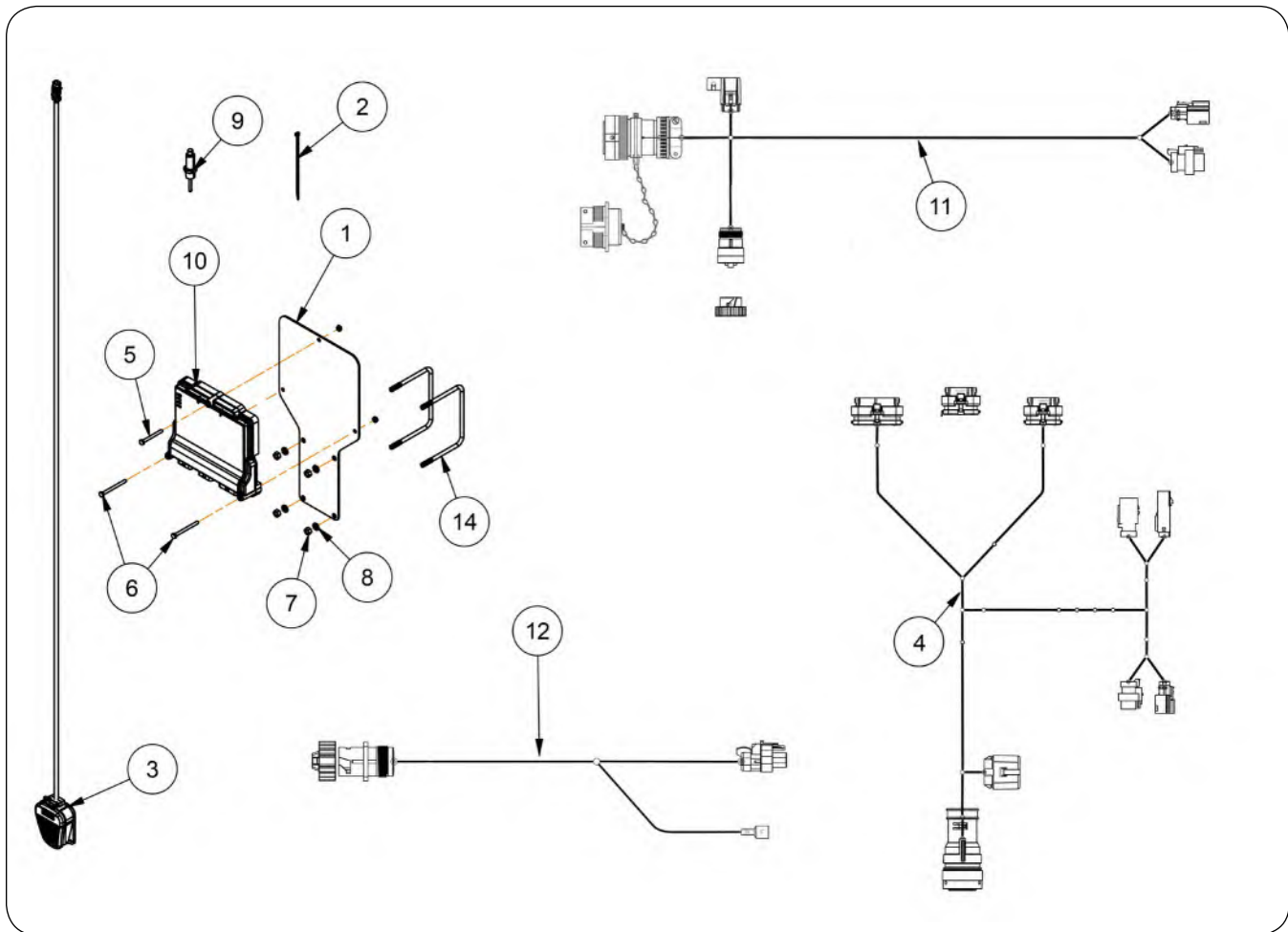

ITEM	PART NUMBER	DESCRIPTION	QTY	NOTES
	43836	ISOBUS Rate Controller		
1	44277B	RCM Mounting Plate	1	
2	9000106	Cable Tie 7 1/2"	6	
3	9005916	Foot Switch, ISO NODE w/Harness	1	
4	9008095	Wire Harness, RCM ECU 47-Pin Rate	1	
5	9390-011	Capscrew, 1/4"-20UNC x 2 1/2" G5	1	
6	9390-013	Capscrew, 1/4"-20UNC x 3" G5	2	
7	9394-006	Hex Nut, 3/8"-16UNC	4	
8	9404-021	Lock Washer, 3/8"	4	
9	9503384	NH3 Vapor Sensor	1	
10	9503386	Rate Control Module	1	
11	9503387	Wire Harness, 12 Ft. Adapter 9-Pin IBIC to Gen 1, Hitch Cable	1	
12	9503390	Wire Harness, Foot Switch 23 Ft.	1	
13	9936	Lock Nut, 1/4"-20UNC	3	
14	JBP3045	U-Bolt, 3/8"-16UNC x 5", 6 7/16" C/C	2	

Raven 450 Rate Controller Option

Please visit www.unverferth.com/parts/ for the most current parts listing.

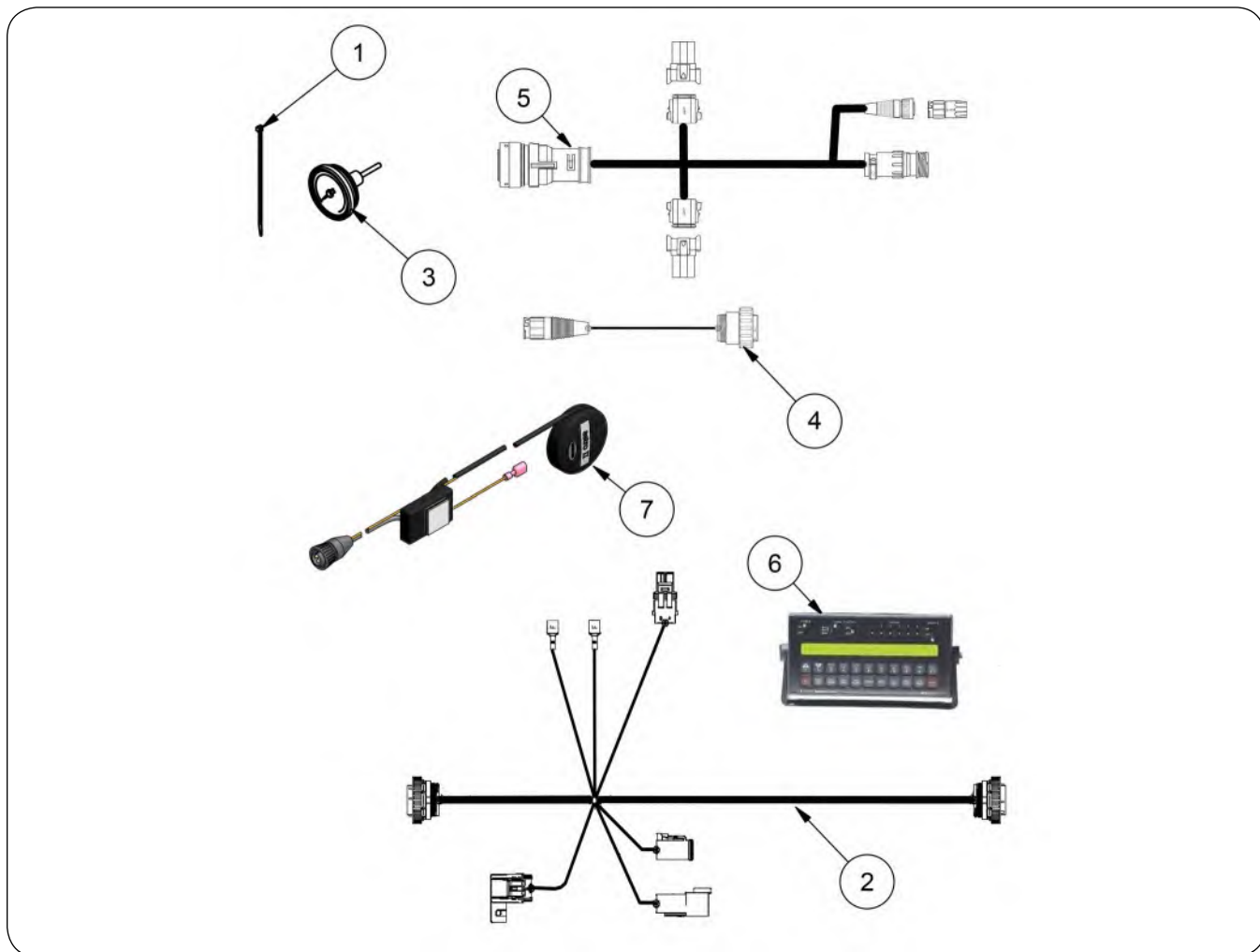

ITEM	PART NUMBER	DESCRIPTION	QTY	NOTES
	43443	Raven 450 Rate Controller		
1	9000106	Cable Tie 7 1/2"	6	
2	9007549	Harness - Console	1	
3	9503298	Temperature Gauge	1	
4	9503395	Wire Harness, Console 10 Ft. (Transducer to Console)	1	
5	9503396	Wire Harness, 16-Pin (Console to 47-Pin Connector)	1	
6	TA720315	Control Console, Raven SCS 450	1	
7	TA723025	Astro GPS Speed Sensor	1	

Lighting Components

Please visit www.unverferth.com/parts/ for the most current parts listing.

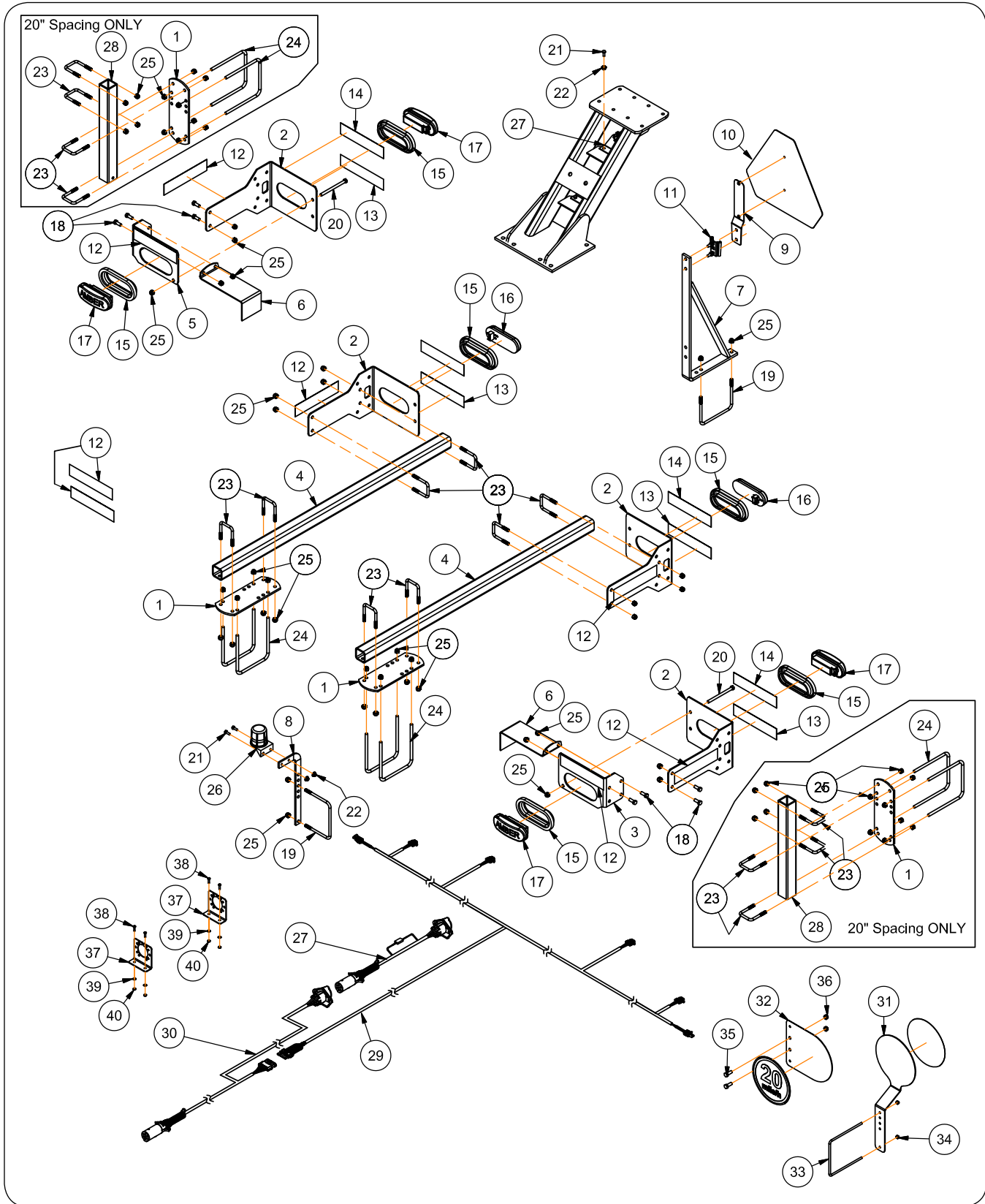

Lighting Components

Please visit www.unverferth.com/parts/ for the most current parts listing.

ITEM	PART NUMBER	DESCRIPTION	QTY			NOTES
			12, 13, 15, 16, 17, 18, 19 ROW 30" SPACING	20 & 21 ROW 30" SPACING	18 & 24 ROW 20" SPACING	
	J41000023	Lighting Kit, For 12/13/15/16/17/18/19 Row 30" Spacing Units	1	-	-	Includes Items 1-27, 29-30
	J41000024	Lighting Kit, For 20 & 21 Row 30" Spacing Units	-	1	-	Includes Items 2-3, 5-22, 25-27, 29-30
	J41000025	Lighting Kit, For 18 & 24 Row 20" Spacing Units	-	-	1	Includes Items 1-30
1	JAM3408	Light Post Mounting Plate	2	-	4	
2	JAM3414	Rear Light Bracket	4	4	4	
3	JAM3415	Front, Left-Hand Light Bracket	1	1	1	
4	JAM3416	Tube Light Bracket, 48"	2	-	2	
5	JAM3417	Front, Right-Hand Light Bracket	1	1	1	
6	JAM3418	Light Bracket Shield	2	2	2	
7	JAM3420	SMV Mounting Bracket, Tall	1	1	1	
8	JAM4575	Dust Cap Holder Bracket	1	1	1	
9	TA510516	SMV Spade Mounting with Hardware	1	1	1	
10	TA510514	SMV Emblem	1	1	1	
11	TA510515	SMV Socket Bracket	1	1	1	
12	9003127	Reflector, AMBER (2" x 9")	8	8	8	
13	9003126	Reflector, RED (2" x 9")	4	4	4	
14	9003125	Fluorescent Strip (2" x 9")	4	4	4	
15	97182	Grommet for Panel Light	6	6	6	
16	902217	Light/RED LED, 10 Diode, 3 Prong Panel Mount	2	2	2	
17	JAP4415	Light/AMBER LED	4	4	4	
18	9390-055	Capscrew, 3/8"-16UNC x 1" G5	16	24	8	
19	JBP3045	U-Bolt, 3/8"-16UNC x 5", 6 7/16"CC	2	2	2	
20	9390-069	Capscrew, 3/8"-16UNC x 5" G5	2	2	2	
21	97420	Flange Screw, 1/4"-20UNC x 3/4" G5	8	8	8	
22	97189	Hex Nut/Large Flange, 1/4"-20UNC	8	8	8	
23	JBP3736	U-Bolt, 3/8"-16UNC x 2"W X 3"L	8	-	16	
24	JBP3351	U-Bolt, 3/8"-16UNC x 7", 6 7/16CC	4	-	8	
25	9398-012	Elastic Lock Nut, 3/8"-16UNC	46	30	62	
26	9001968	Connector Holder	1	1	1	
27	JAP3223	Plug Electrical Harness (AP Plug to 7P RV Socket)	1	1	1	
28	JAM3419	Tube Light Bracket, 17 5/8"	-	-	2	
29	JAP3222	Rear Electrical Harness 27'	1	1	1	
30	JAP3221	Branch Electrical Harness 33'	1	1	1	
31	79340B	SIS Bracket with Decal	1	1	1	
32	79339B	SIS Plate with Decal	1	1	1	
33	97898	U-Bolt, 1/4"-20UNC x 6 5/8", 6 1/4" C/C	1	1	1	
34	9936	Lock Nut/Top, 1/4"-20UNC	2	2	2	
35	9390-055	Capscrew, 3/8"-16UNC x 1" G5	2	2	2	
36	9928	Lock Nut/Top, 3/8"-16UNC	2	2	2	
37	45304B	Universal Mounting Bracket	2	2	2	
38	903172-136	Pan Head #10-24UNC x 3/4", Phillips Machine Screw	4	4	4	
39	9405-050	Flat Washer, #10 SAE	4	4	4	
40	9830-017	Hex Nut, #10-24UNC	4	4	4	



Unverferth[®]
Manufacturing Company, Inc.

www.unverferth.com